



The  
**Fibonacci**  
Project

DISSEMINATING INQUIRY-BASED SCIENCE  
AND MATHEMATICS EDUCATION IN EUROPE

COMPANION RESOURCES FOR IMPLEMENTING  
INQUIRY IN SCIENCE AND MATHEMATICS AT SCHOOL

# IMPLEMENTING INQUIRY IN MATHEMATICS EDUCATION

PETER BAPTIST, DAGMAR RAAB  
(EDS.)



WITH THE SUPPORT OF





## Resources for Implementing Inquiry in Science and Mathematics at School

The Fibonacci Project (2010-2013) aimed at a large dissemination of inquiry-based science education and inquiry-based mathematics education throughout the European Union. The project partners created and trialled a common approach to inquiry-based teaching and learning in science and mathematics and a dissemination process involving 12 Reference Centres and 24 Twin Centres throughout Europe which took account of local contexts.

This booklet is part of the *Resources for Implementing Inquiry in Science and in Mathematics at School*. These Resources include two sets of complementary booklets developed during the Fibonacci Project:

### 1) Background Resources

The *Background Resources* were written by the members of the Fibonacci Scientific Committee. They define the general principles of inquiry-based science education and inquiry-based mathematics education and of their implementation. They include the following booklets:

- 1.1 Learning through Inquiry
- 1.2 Inquiry in Science Education
- 1.3 Inquiry in Mathematics Education

### 2) Companion Resources

The *Companion Resources* provide practical information, instructional ideas and activities, and assessment tools for the effective implementation of an inquiry-based approach in science and mathematics at school. They are based on the three-year experiences of five groups of Fibonacci partners who focused on different aspects of implementation. The *Companion Resources* summarise the lessons learned in the process and, where relevant, provide a number of recommendations for the different actors concerned with science and mathematics education (teachers, teacher educators, school directives, deciders, policy makers...). They include the following booklets:

- 2.1 Tools for Enhancing Inquiry in Sciences Education
- 2.2 Implementing Inquiry in Mathematics Education
- 2.3 Setting up, Developing and Expanding a Centre for Science and/or Mathematics Education
- 2.4 Integrating Science Inquiry across the Curriculum
- 2.5 Implementing Inquiry beyond the School

Reference may be made within this booklet to the other *Resource* booklets. All the booklets are available, free of charge, on the Fibonacci website, within the *Resources* section.

Editorial coordinator: Susana Borda Carulla

Fibonacci Scientific Committee: Michèle Artigue, Peter Baptist, Justin Dillon, Wynne Harlen, David Jasmin, Pierre Léna

[WWW.FIBONACCI-PROJECT.EU](http://WWW.FIBONACCI-PROJECT.EU)

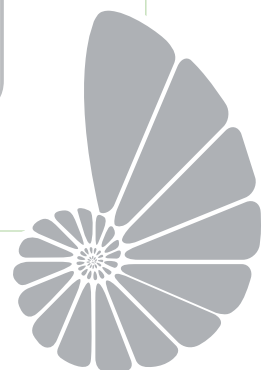

Fibonacci Project, December 2012

*This project has received funding from the European Union's Seventh Framework Programme*



Peter Baptist, Dagmar Raab (eds.)

# IMPLEMENTING INQUIRY IN MATHEMATICS EDUCATION



The target group of this book includes teachers,  
teacher trainers, decision makers, parents,  
and all the other people interested in the  
development of mathematics education in Europe.

ISBN 978-3-00-040752-9

Editorial coordinator : Dagmar RAAB, University of Bayreuth, Germany

Scientific advisor : Peter BAPTIST, University of Bayreuth, Germany

Authors: Peter BAPTIST,  
University of Bayreuth, Germany

Toni CHEHLAROVA,  
Institute of Mathematics and Informatics,  
Bulgarian Academy of Sciences, Bulgaria

Matthias EHMANN,  
University of Bayreuth, Germany

Peter GALLIN,  
University of Zurich, Switzerland

Michael GERHÄUSER,  
University of Bayreuth, Germany

Roman HAŠEK,  
University of South Bohemia,  
Faculty of Education, Czech Republic

Markus JETZER- CAVERSACCIO,  
Secondary school Kalktarren, Schlieren, Switzerland

Petar KENDEROV,  
Institute of Mathematics and Informatics,  
Bulgarian Academy of Sciences, Bulgaria

Carsten MILLER,  
University of Bayreuth, Germany

Pavel PECH,  
University of South Bohemia, Czech Republic

Vladimíra PETRÁŠKOVÁ,  
University of South Bohemia,  
Faculty of Education, Czech Republic

Dagmar RAAB,  
University of Bayreuth, Germany

Libuše SAMKOVÁ,  
Faculty of Education,  
University of South Bohemia, Czech Republic

Evgenia SENDOVA,  
Institute of Mathematics and Informatics,  
Bulgarian Academy of Sciences, Bulgaria

Jörg TRIEBEL,  
Thuringian Ministry of Education, Science and Culture, Germany

Volker ULM,  
University of Augsburg, Germany

Heiko VOGEL,  
University of Bayreuth, Germany

Alfred WASSERMANN,  
University of Bayreuth, Germany



## The Fibonacci project brings back maths into classrooms

In many classrooms the same ritual presents itself each day: Teacher stands in front of class at the black- or whiteboard demonstrating methods. Students copy the methods down in their books and then work through sets of near-identical tasks, practising the methods. This type of teaching is not only dry and boring but also highly ineffective. Students learn very fast that the way to be successful in maths is to watch the teacher carefully and to copy what he/she does. So it is even possible that students leave school with fairly good grades in maths but no understanding of what they are doing.

But how can we promote mathematical understanding? How can our maths classrooms become centres of vivid mathematical thinking? The message is clear: We have to follow the American mathematician Paul Halmos who demanded: "Don't preach facts, stimulate acts." Problem solving and creating new problems belong to the essence of mathematics. This is the focus of our Fibonacci project. The inquiry-based approach to teaching and learning helps to develop mathematical thinking skills and to understand fundamental ideas and methods. We do not start with formulas and rules, we get them at most at the end of the learning process. Mathematics is a participatory sport. Therefore we prefer an experimental approach. We have to create situations that challenge the students' curiosity. Teachers should pose problems proportionately to their students' knowledge and help them to solve these problems with stimulating questions. More than by reading and listening, mathematics is learned by really doing maths. That means by analysing situations, by making guesses and conjectures, by computing, by problem solving, and by discussing ideas with other students. And, in analogy to learning a sport, making mistakes and then making adjustments are clear parts of the experience. When students are given opportunities to ask their own questions and to extend problems in new directions, they know mathematics is still alive, not something that already has been decided and just needs to be memorised.

After the decision for inquiry-based learning in maths, teachers need structuring elements to organise classroom work and learning processes. In the Fibonacci project we have chosen so-called basic patterns\* to indicate which direction teaching should take. These basic patterns can be regarded as an overarching concept for implementing inquiry-based maths education in the classroom and in teacher education (cf. [chapter 2](#)). But to initiate a change in teaching and learning we have to provide teachers with suitable examples, we have to develop new materials together with the teachers.

All our Fibonacci maths partners have really done an excellent job. We have exceeded our target achievements without disregarding the high quality of our work. There has been a very productive and intensive collaboration between the different Fibonacci centres and the participating schools.

We mustn't forget that each country has its own tradition in teaching and learning. Teachers and parents only accept changes when this tradition is respected and changes take place in small steps. So our examples show the variety of inquiry-based approaches (also including ICT) in Bulgaria, Czech Republic, Germany, and Switzerland.

I want to use this opportunity to thank all the teachers in the participating European countries who have been extremely committed in the Fibonacci project. Although the EU project is now finished I am convinced that our Fibonacci ideas will survive because they have been proved as a stable basis for inspiring and sustainable teaching and learning. With the Fibonacci project we have started a fast growing dissemination process similar to the iterative growth of the Fibonacci sequence.

Peter Baptist

---

\* The scientific committee has characterised the "basic patterns" as "key features of inquiry pedagogy", thus underlining the importance of this concept for the Fibonacci Project.

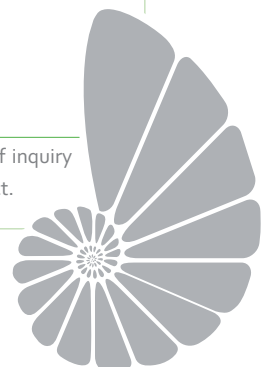

# Table of contents

---

## 1 Towards New Teaching in Mathematics ..... 1

*Peter Baptist*

- 1.1 What is mathematics? – What a question! ..... 1
- 1.2 Reconsidering one’s own teaching – a guiding concept for Fibonacci teachers..... 4
- 1.3 Considerations by Günter M. Ziegler: The impact of the Bayreuth Fibonacci Conference (September 2010) on teaching and learning mathematics ..... 5
  - 1.3.1 What is mathematics? Answers by G. M. Ziegler ..... 5
  - 1.3.2 Comments on Ziegler’s concept ..... 7
- 1.4 Learning mathematics as inquiry ..... 8

## 2 The Basic Patterns as Key Aspects of Inquiry Pedagogy ..... 13

### 2.1 The concept of basic patterns ..... 13

*Dagmar Raab*

- 2.1.1 Basic patterns as an underlying core structure ..... 13
- 2.1.2 What is special about this overarching concept? ..... 13

### 2.2 How to work with basic patterns ..... 14

*Peter Baptist, Dagmar Raab*

- 2.2.1 Developing a problem-based culture ..... 14
- 2.2.2 Promoting cumulative learning ..... 16
- 2.2.3 Learning from mistakes ..... 18
- 2.2.4 Experiencing subject boundaries and interdisciplinary approaches ..... 20

<b>2.3 Dialogic learning – from an educational concept to daily classroom teaching .....</b>	<b>23</b>
<i>Peter Gallin</i>	
2.3.1 Genesis and theory of dialogic learning .....	23
2.3.2 Working with “I – You – We” as a teaching aid .....	28
<b>3 IBME and ICT .....</b>	<b>35</b>
<b>3.1 The use of dynamic geometry systems (DGS) and computer algebra systems (CAS) in IBME .....</b>	<b>35</b>
<i>Pavel Pech</i>	
3.1.1 Introduction .....	35
3.1.2 Verification and proving theorems .....	35
3.1.3 Deriving theorems .....	41
3.1.4 Locus equations .....	42
3.1.5 Conclusions .....	47
<b>3.2 IBME and ICT – the experience in Bulgaria .....</b>	<b>47</b>
<i>Petar Kenderov, Evgenia Sendova, Toni Chehlarova</i>	
3.2.1 Digital learning environments in support of the IBME .....	47
3.2.2 Basic types of dynamic learning environments .....	48
3.2.3 Discussion .....	54
<b>3.3 Interactive geometry for the web and mobile devices .....</b>	<b>54</b>
<i>Matthias Ehmann, Michael Gerhäuser, Carsten Miller, Heiko Vogel, Alfred Wassermann</i>	
3.3.1 Introduction .....	54
3.3.2 JSXGraph .....	56
3.3.3 JessieCode .....	59
3.3.4 Sketchometry .....	60
3.3.5 Conclusion .....	61



## 4 IBME in Schools: Overview and Examples in International Contexts ..... 65

### 4.1 Inquiry-based mathematics education in primary school: Overview and examples from Bavaria/Germany ..... 65

*Volker Ulm*

4.1.1 Heterogeneity in primary school .....	65
4.1.2 Aspects of learning .....	69
4.1.3 Inquiry-based learning .....	70
4.1.4 Learning environments for IBME .....	70
4.1.5 Tasks for IBME .....	71
4.1.6 Teaching methods for IBME .....	72
4.1.7 Example for arithmetic: Windows on the hundreds chart .....	73
4.1.8 Example for geometry: Quadruples .....	77

### 4.2 The current state of IBME in the Czech Republic ..... 82

*Libuse Samkova*

4.2.1 IBME from the perspective of the Czech framework educational programme .....	82
4.2.2 Twin centre Budweis and its background .....	82
4.2.3 Czech teachers and their experience .....	83
4.2.4 Digest of learning environments created within the Fibonacci project .....	84
4.2.5 IBME at Czech vocational schools .....	93

### 4.3 IBME in teaching and learning financial literacy topics – selected teaching methods for financial education ..... 94

*Roman Hašek, Vladimíra Petrášková*

4.3.1 Introduction .....	94
4.3.2 A teaching method .....	94
4.3.3 Classification of teaching methods .....	94
4.3.4 Problem-based teaching method .....	95
4.3.5 Situation method .....	100
4.3.6 Project method .....	104



<b>4.4 IBME in primary schools in Bulgaria: Some examples of dynamic scenarios and their implementation in a class setting.....</b>	<b>106</b>
<i>Toni Chehlarova</i>	
4.4.1 Counting rectangles .....	106
4.4.2 Explorations with a virtual analogue clock .....	110
<b>4.5 IBME in the secondary school: Overview and examples in a Bulgarian context .....</b>	<b>114</b>
<i>Toni Chehlarova, Evgenia Sendova</i>	
4.5.1 Overview – the lessons from the first IBME&ICT attempts 25 years ago ....	114
4.5.2 Best practices in designing dynamic scenarios and implementing them in Bulgarian Fibonacci schools .....	115
<b>4.6 IBME in the secondary school: Examples from Switzerland ..</b>	<b>125</b>
<i>Peter Gallin, Markus Jetzer-Caversaccio</i>	
4.6.1 On the equilibrium between offer and use – a practical example from a Swiss upper secondary school: The offer-and-use model within the context of dialogic learning .....	125
<i>Peter Gallin</i>	
4.6.2 Dialogic learning: An example from a classroom situation at lower secondary school level .....	133
<i>Markus Jetzer-Caversaccio</i>	
<b>4.7 Fibonacci in Thuringia/Germany – inquiry-based learning in interdisciplinary lessons .....</b>	<b>141</b>
<i>Jörg Triebel</i>	
4.7.1 Spirals .....	142
4.7.2 The golden section .....	143
4.7.3 The golden angle .....	143
4.7.4 Fibonacci numbers .....	144

## **5 IBME in Teacher Education ..... 151**

### **5.1 In-service teacher training in the Czech Republic ..... 151**

*Libuse Samkova*

### **5.2 How to encourage teachers to participate in IBME activities ..... 151**

*Libuse Samkova*

### **5.3 The specifics of the teacher education within the Fibonacci project in Bulgaria ..... 154**

*Evgenia Sendova, Toni Chehlarova*

#### **5.3.1 Teacher training courses promoting a new role for the teachers ..... 155**

#### **5.3.2 The follow-up events and the international component ..... 155**

#### **5.3.3 Enhancing the teachers' involvement in the dissemination of IBME ..... 157**

#### **5.3.4 The lessons learned ..... 160**

## **6 Inquiry Based Mathematics Education (IBME) and Gifted Students ..... 163**

*Petar Kenderov, Evgenia Sendova*

### **6.1 Introduction ..... 163**

### **6.2 The High School Students' Institute – a Bulgarian model of mathematics and informatics research at school age ..... 164**

### **6.3 The RSI international summer program and the challenge to describe it by one word ..... 168**

# 1 Towards New Teaching in Mathematics

---

*Peter Baptist*

## 1.1 What is mathematics? – What a question!

Most people do not have an accurate picture of mathematics. They view mathematics as a set of formulas to be applied to a list of tasks and problems at the end of a textbook chapter. But that's not maths at all.

The reason for this misjudgement is the way, how maths is frequently taught at schools. Often people assume that maths is the study of numbers and shapes. But maths is more. In fact, the answer to the question "What is mathematics?" has changed several times during the course of history and it is neither possible nor necessary to give a precise answer. A good approach to a reasonable answer is to observe how mathematicians work.

### Open your mind for the beauty of mathematics

Problem solving is at the core of a mathematician's work and it often starts with the making of a guess. Afterwards mathematicians engage in a process of conjecturing, refining with counterexamples, and the proving. Such work is exploratory and creative, and many insiders draw parallels between mathematical work and art or poetry or music (cf. also 8, 17, 10). Here one likes to quote the famous English number theorist *Godefrey Harold Hardy* (1877 – 1947): "A mathematician, like a painter or a poet, is a maker of patterns. If his patterns are more permanent than theirs, it is because they are made with ideas. ... The mathematician's patterns, like the painter's or poet's, must be *beautiful*, the ideas, like the colours or the words, must fit together in a harmonious way. Beauty is the first test; there is no permanent place in the world for ugly mathematics" <sup>12</sup>.

This beauty to which Hardy is referring is a very specific one, he thinks of abstract forms and logical structures. The outstanding mathematician and philosopher *Bertrand Russell* (1872 – 1970) denotes this beauty as "cold and austere". In the first instance this kind of beauty can only be appreciated by mathematical people, but it is a very important task to open the minds of all people interested in this beauty. There are a lot of appropriate examples like Euclid's ingenious proof that there are infinitely many primes or the existence of only five regular polyhedrons.

### Mathematics as science of patterns

Maths as the study and classification of patterns should be used in a very wide sense, to cover almost any kind of regularity that can be recognised by mind. According to *Keith Devlin* maths as the science of patterns is a way of looking at the world, both the physical, biological, and sociological world we inhabit and the inner world of our minds and thoughts.

The American novelist and journalist *Rick Shefchik* has illustrated this perspective in his weekly newspaper column *Go Ask Dad*. I am quoting from *How many journalists does it take to ...*

"The call from my wife came at about 4 p.m. while I was at the office – the kind of a call every parent dreads. "If twelve kids are standing in line at a drinking fountain, in how many different orders can they stand?" I paused to let her question sink in. There would be no doubt about it. This was our 14-year-old daughter's math homework.

"I don't have any idea," I admitted. "One hundred and forty-four?" (*Remark: This kind of answer is very typical. A person has no proper idea how to solve the given problem, but nevertheless he blindly uses a formula or an arithmetic operation – here  $12^2 = 144$  – without any careful thinking about the problem.*) "She says that's not right." "Does her book say how to do it?" "She didn't bring her book home today. That's why we called you. We thought somebody there might know how to do it." I glanced around me. I was surrounded by some of the finest minds the American college and university system had ever turned out. Unfortunately, they were all journalists. "Anybody know how many different ways twelve kids can stand in line at a drinking fountain?" I asked those nearest me.

The math poison slowly spread from desk to desk. Tiny beads of sweat popped up on a few foreheads as these English and journalist majors experienced tragic flashbacks to math classes they barely escaped with their lives. "One hundred and forty-four?" somebody guessed. "I'm told that's not right," I said. "There's only one way," another scribe said. "The way the teacher tells them to stand." Well, he obviously hadn't been in a school for several decades. Besides, that wasn't the answer the math homework sheet was looking for.

I told my wife we were stumped, and I expected all of us go back to writing our tight, prize-winning declarative sentences. But the question lingered in the air: How many ways can you line up twelve kids at a drinking fountain? I began bouncing ideas back and forth with my two nearest colleagues ...

We began with scratch pads. Two people, we rapidly figured out, can stand in only two possible orders. Three can stand in six possible orders. Then it got hard – but when one of my colleagues wrote down all the possible combinations on a reporter's notebook and counted 24 of them, "**we detected a pattern emerging ...**"

In my opinion this cutting from the newspaper column is an excellent example of an experimental access to mathematics. The journalists discovered for themselves how mathematicians work, how mathematical ideas arise. Working with special cases and generalizing afterwards are powerful strategies, not only for solving mathematical problems <sup>2</sup>. This kind of learning has to be practised more often in our classrooms. I remind you of the American mathematician Paul Halmos (1916 – 2006) who demanded: "Don't preach facts, stimulate acts!" <sup>3</sup>

## Jost's mathematical garden – Fibonacci flowers

The Swiss painter *Eugen Jost* compares mathematics with a huge garden with a lot of flowerbeds that are connected by broad alleys and intricate pathways. He moves in this garden not as a gardener or biologist but as a friend of flowers. He picks colourful bunches of flowers and collects rare flowers. All these flowers are ingredients of his paintings (see Fig. 1 - Fig. 3). Beauty of mathematics: this time not "cold and austere" but attractive and appealing.



Fig. 1: Eugen Jost, Hardy's Taxi



Fig. 2: Eugen Jost, Mediterranean Geometry

Jost's painting *Girasole* (Fig. 3) shows natural numbers in the right part and a rectangle that consists of coloured squares in the left. This geometric pattern is a visual interpretation of the number sequence 1, 1, 2, 3, 5, 8, 13, 21, 34, ... on the right.

These numbers play an important role in *Dan Brown's* thriller *The Da Vinci Code*. Of course this number sequence is much older. In 1202 a remarkable book appeared that brought the decimal numeral system to the western world. (Up to this time the most common system in use was the Roman numeral system.) In his *liber abaci* (= book of calculation) *Leonardo of Pisa* (ca. 1170 – ca. 1240), also called *Fibonacci*, described the Hindu-Arabic numerals and the place-valued decimal system for expressing numbers. Like in modern algebra texts we also find word problems in the *liber abaci*:

*How many pairs of rabbits will be produced in a year, beginning with a single pair, if in every month each pair begets a new pair that from the second month on becomes productive?*

The resulting sequence of pairs of rabbits, now known as Fibonacci sequence, is

1, 1, 2, 3, 5, 8, 13, 21, 34, ...

In the last line of the painting we read the word *GIRASOLE* that is the Italian word for *sunflower*. If you look very carefully at the photograph of the sunflower (Fig. 4) you will recognise that the seeds in the centre of the flower form spirals, some of which curve to the left and some to the right.

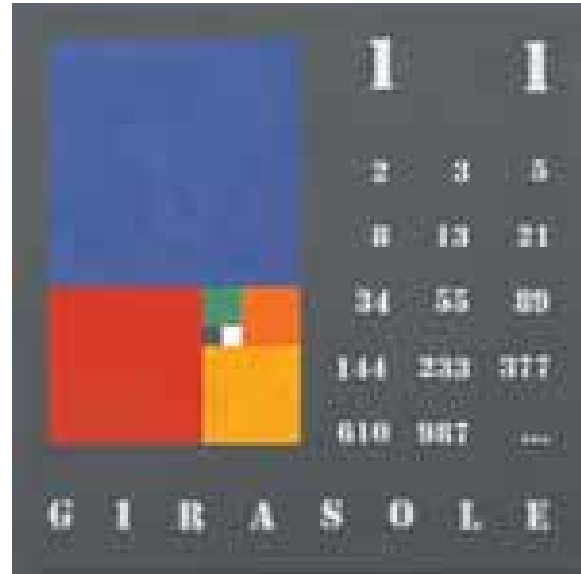

Fig. 3: Eugen Jost, *Girasole*

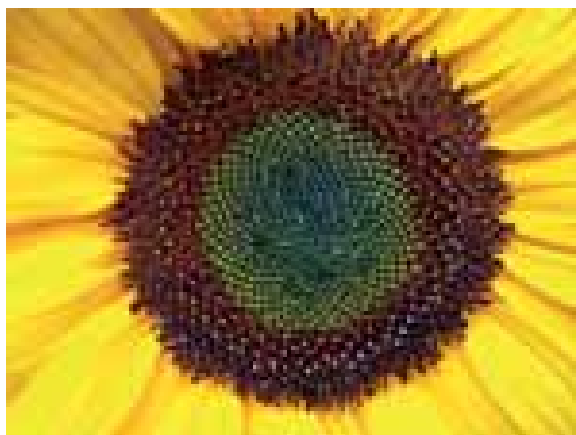

Fig. 4: Sunflower

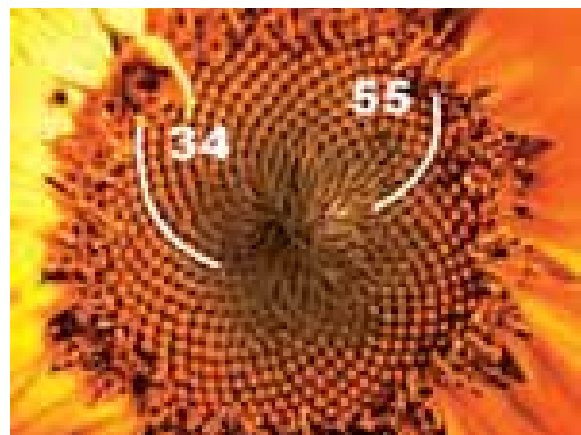

Fig. 5: Sunflower with 34 and 55 Fibonacci spirals

Counting the spirals running clockwise and counter clockwise one gets two successive Fibonacci numbers (Fig. 5). These numbers appear in other biological settings such as fruitlets of a pineapple or seeds of a pinecone, too.

Now we consider quotients of successive Fibonacci numbers:

$$\frac{1}{1}, \frac{2}{1}, \frac{3}{2}, \frac{5}{3}, \frac{8}{5}, \frac{13}{8}, \frac{21}{13}, \frac{34}{21}, \frac{55}{34}, \dots$$

Dividing each number by the predecessor, we produce ratios that get closer and closer to 1,618 ..., also known as the golden ratio. This ratio exists in nature and it turns out to be so pleasing to the eye that it is often used in art and architecture (e.g. Parthenon in Athens).

With the Fibonacci numbers we experience maths as an important part of our culture (cf. also 9). On the other hand we have a stimulating context where we have the opportunity to encounter different number systems such as natural numbers, fractions, decimal fractions (finite, periodic, semi-periodic), irrational numbers (golden ratio). The next picture (Fig. 6) illustrates this extensive context for teaching and learning mathematics and formal education.

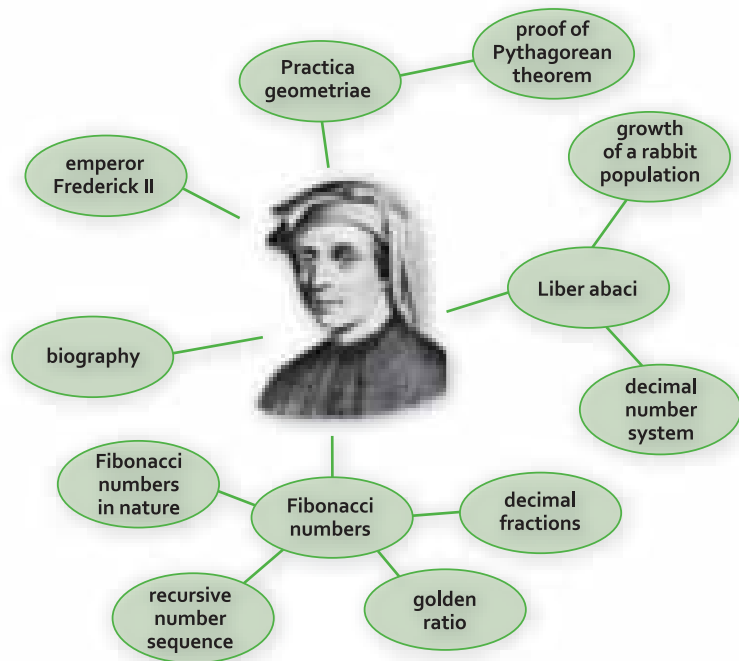

Fig. 6

## 1.2 Reconsidering one's own teaching – a guiding concept for Fibonacci teachers

There is no doubt that successful instruction has an individual face that is primarily that of the individual teacher. Well-prepared project ideas and materials provide inspiration, but implementation always has a personal touch.

What distinguishes successful mathematics education at school? How can inquiry-based mathematics education be realised? Access to our Fibonacci philosophy is best achieved through conscious consideration of one's own teaching. Here certain central themes can serve as means of orientation. These themes take five different aspects of teaching into consideration:

- teaching style
- work with problems/tasks
- technical contents
- type of achievement testing
- the role as a mathematics teacher.

Each of these items contains a lot of ideas and requires further detailed explanations. For that I refer to my article *Towards Teaching and Learning Inquiry-Based Mathematics* in the *Background Resources* <sup>5</sup>.

## 1.3 Considerations by Günter M. Ziegler: The impact of the Bayreuth Fibonacci Conference (September 2010) on teaching and learning mathematics

### 1.3.1 What is mathematics? Answers by G. M. Ziegler

In his stimulating and in the meantime much debated talk <sup>19</sup> Ziegler investigated the question of the primary goal of mathematics education at school. He identified not only one goal but at least three. At first he tried to clarify what mathematics is. Let's have a look on his presentation.

What is mathematics? What do you think? Today's school kids may ask *Wikipedia* for help – and be disappointed. Indeed, *Wikipedia* won't help you on that:

"Mathematics is the study of quantity, structure, space, and change. Mathematicians seek out patterns, formulate new conjectures, and establish truth by rigorous deduction from appropriately chosen axioms and definitions."

Indeed, the German version of *Wikipedia* goes one step beyond this, and as part of the definition of mathematics it stresses that there is no commonly accepted definition. I translate:

"Mathematics is the science that developed from the investigation of figures and computing with numbers. For mathematics, there is no commonly accepted definition; today it is usually described as a science that investigates structures that it created itself for their properties and patterns."

Is this a good answer? I believe that if you ask education bureaucrats, you will often find the belief that the question *What is mathematics?* is answered by high-school curricula. But what kind of answer do these curricula give?

If you ask university mathematicians the same question, they might point you to a very successful book by Richard Courant and Herbert Robbins that has the title *What is Mathematics?* <sup>22</sup>.

However, this is a question – what is the answer? Indeed, the book called *What is Mathematics?* was first supposed to be called something like "mathematical discussions of some basic elementary problems for the general public" – before Thomas Mann convinced Richard Courant that *What is Mathematics?* is the title that would sell more copies. The subtitle of the latest paperback edition gives more information: "An Elementary Approach to Ideas and Methods".

Such investigations could give an idea about what mathematics is – but is that all? What is mathematics? It is at least three things at the same time, which we should consider separately, and to a certain extent also teach separately:

- I. A collection of basic tools, part of everyone's survival kit for modern real life.
- II. A field of knowledge with a long history, part of our culture, an art, but also very productive, indeed a production factor, basis of all modern key technologies.
- III. A highly developed, active, huge research subject.



Fig. 7

As a consequence of these considerations Günter M. Ziegler finds out that one subject mathematics at school is not enough. Instead he asks for three subjects: Basic Tools, Field of Knowledge (with Applications), Research Subject.

### **Mathematics I: Basic Tools**

Of course, a primary goal of mathematics education at school must be to equip all pupils with basic mathematics knowledge and abilities. If we are honest, it is not so much mathematics that we really all need and use in everyday life. But it does include numbers, geometric shapes, probabilities, percentages, and little more than that. However, when have you last solved a quadratic equation in real life? Differentiated a function?

My impression is that this part is the only one that gets any reasonable fraction of space on the school curricula in many countries – but teaching fails miserably, actually for many different reasons, but one of them is lack of motivation, which stems from the fact that kids are not interested in the topic, which is Mathematics I without Mathematics II-III.

### **Mathematics II: Field of Knowledge (with Applications)**

Where does the subject come from? There are 6,000 years of mathematics (or even 22,000 years) full of stories, of history, of developments, of motivation. Indeed, this part of mathematics should probably be taught at school in close cooperation or even jointly with physics and astronomy, as they are so deeply linked.

The fact that mathematics is not only a set of rules and a finished product, but that it has history is most important for the view of “what is mathematics?” – meet the heroes! Stories about Archimedes, Euler, Gauß, Sonja Kovalevskaya, Andrew Wiles, Grigoriy Perelman, Terry Tao or Lisa Sauermann that can shape the image of what mathematics is about!

This is also the subject where we can and should connect mathematics with the other arts! This is where students can experience and feel mathematics. Mathematics as a subject is alive!

Part of *Mathematics as a Field of Knowledge* has to be a multitude of answers to the question: What is mathematics good for? Indeed, many students need these answers as part of their motivation for studying mathematics. Perhaps you are aware of the fact that mathematics is a key component of virtually all modern key technologies. All students have to learn about this. They should also get a chance to get in touch with this, as concretely as possible. Try it out! If possible, on real problems, real data!

### **Mathematics III: Research Subject**

Tell all of them about it! You cannot teach “mathematics research” to all the kids in school, but you have to show them that it exists. That mathematics is alive, that it is constantly changing. That it is a huge subject, always expanding! That it encompasses dozens of fantastic areas of studies that you never will hear about at school, such as topology, ergodic theory, measure theory, group theory, Galois theory, Lie theory, etc.

Also a part of Mathematics III: Prepare for University! That is, provide basics, namely all you need to know and to be able to do if you want to study (maths, or any science, or medicine, or any other advanced subject). Clearly this should include the basic concepts that will be needed for a successful start into university studies – concepts such as logic, functions, basic calculus, but perhaps more important: proofs!

Indeed, Mathematics III needs to provide skills for mathematics as a research subject – therefore it should also contain proofs, problem solving strategies, and preparation and possibly training for mathematics competitions, – on all different levels, from Kangaroo (for all the kids) to the International Mathematical Olympiads (for only a few).



### 1.3.2 Comments on Ziegler's concept

I'd like to add some comments on Ziegler's concept of Mathematics III. Especially the last section is important for school. The finding and application of problem solving strategies and problem solving itself deliver an excellent feeling of what mathematics research can be. There is a lot of literature in this field (cf. [list of references](#)). Still a "must" is George Polya's famous book *How to Solve It*<sup>14</sup>. Polya divides the problem solving process in four phases: Understanding the problem, devising a plan, carrying out the plan, looking back. Over the years there have been made suggestions to expand the fourth phase<sup>3</sup>: Not only looking back, but also looking forward. That means for example generalisations, variations of the problem, etc.

#### **Example: Calculating with the hours of a day**

The face of a clock shows the numbers 1 through 12. Take all twelve numbers and use addition and subtraction to create a term resulting zero.

Try to find several ways of doing it. What do your results have in common?

#### *Varying the task*

- Take the six numbers 2, 4, 6, 8, 10, 12 and use addition and subtraction to produce a term resulting in zero.
- Can you do the same with the six uneven numbers?
- Can you do the same with the numbers 1 through 11 or 1 through 10?
- Suppose the clock falls down and the face splits into three parts. Is it possible for the sum of the numbers on each part to be the same?

I do not fully agree with Günter Ziegler that we should teach Mathematics I, II, and III to a certain extent separately. Our major goal is to enhance the mathematical understanding and knowledge of the pupils. Therefore we initially have to improve

- their attitude and appreciation towards mathematics,

and then

- their ability to use mathematics in real world contexts.

For that reason we have to create a stimulating learning atmosphere. That means we start with learning environments from Mathematics II in combination with Mathematics III. It depends of the age and the smartness of the students how extensive contents of Mathematics III are considered. Thus getting involved in interesting mathematical problems students are more likely willing to do routine exercises and to transform equations and formulas. This is a condition sine qua non for sustainable learning of Mathematics I.

## 1.4 Learning mathematics as inquiry

In my opinion two of the most important questions we have to answer are: What kind of mathematical knowledge should remain after school? What is the contribution of mathematics in school to general education?

Of course basic mathematics like basic arithmetic, percentage, understanding various kinds of diagrams, spatial visualisation are necessary for everybody in our world. All these things belong to Mathematics I described above. But do we really need 12 school years for that? I remember the severe discussions we had in Germany on H. W. Heymann's provocative demand that seven years of maths be enough.

Maths education in addition to Mathematics II and III must have an ambitious goal, especially at the Gymnasium. I am sure - after a shorter or longer time - most people will forget the details and formulas they have learnt at school. That's a normal process. But what should, what has to remain of the numerous hours of maths lessons besides the "Mathematics I basics"? A reasonable answer is: A well-educated person should be able to have a conversation with a mathematician that is interesting for both partners.

Therefore teachers must also help students to understand the concepts of mathematics, not just the mechanics of how to solve a certain problem. Teachers mustn't present ready to consume mathematics. They have to stimulate students to explore, to observe, to discover, to assume, to explain, and even to prove. These activities characterise how to do mathematics in research. Why shouldn't we work in the same way in the classroom?

### Students have to ask questions – not only teachers

All the mathematical methods and relationships that are known and taught to students started once as questions, yet students do not see the questions any more. Instead they are taught content that often appears as a long list of answers to questions that nobody has ever asked. But it's the question that drives mathematics. When students are given opportunities to ask their own questions and to extend problems into new directions, they know mathematics is still alive, not something that has already been decided and just needs to be memorised.

For this reason we propagate inquiry-based learning. Inquiry is the process by which we don't ask: "What is what we know?" but "What are the things that we don't know and what questions can we ask about them?" The possibilities of that process are almost limitless, but at school they are bounded by some institutional restrictions, for example curriculum, limited time, assessment. Following Hans Freudenthal's (1905 – 1990) idea of mathematics as a human activity, students should not be considered as passive recipients of ready-made mathematics. IBME provides opportunities to ask questions, to solve problems, to imagine, to explore. IBME allows students to reinvent parts of mathematics by themselves.

To begin such a learning process we follow the already above cited Paul Halmos: "Don't preach facts, stimulate acts". For instance we start with the question: What is the best way to design the surface of a golf ball? In contrast to a table tennis ball the surface of a golf ball is not smooth. Why not? Solving this problem we meet a lot of interesting geometric themes, for example volume and surface of a sphere, regular polygons, tessellation of a plane and of a sphere etc. (cf. also 3). Each of these topics stimulates new investigations.

Here you see my point: At the beginning there is a real world context. The study of the golf ball problem opens the students' minds for several standard topics of the curriculum in geometry. The students get the feeling that maths can be part of their lives.

In the three booklets *Towards New Teaching in Mathematics* (Bayreuth 2011, all articles are also available online at <http://www.sinus-international.net>) you will find a lot of examples for your work in the classroom. The articles by M. Artigue<sup>1</sup> and P. Baptist<sup>5</sup> deliver more detailed and also general considerations on IBME.

## The open-ended approach to IBML <sup>\*</sup>

Open-ended problems confront students with a situation or a challenge. Examples are newspaper items, interesting or astounding pictures, real-life situations, geometrical configurations, and special number sequences.

**Example:** *Speeding drivers* (from a newspaper, 1991)

Some years ago, every tenth driver exceeded the speed limit at some time or other. Nowadays it is only every fifth. But even five per cent of drivers are too many. So speed checks are still with us, and drivers exceeding the speed limit will have to pay up.

This newspaper item encourages discussion, reasoning, diverse directions and levels of thinking. In contrast to many traditional tasks it enables everyone to make a start. And additionally it has a diagnosis function: From the answers the teacher can deduce the understanding of percentages that the students have developed.

Open-ended situations enable students

- to gain their own individual overview of the situation presented to them by selecting, getting, and evaluating information,
- to develop questions or conjectures,
- to explore individual paths in order to answer the questions posed or to validate conjectures,
- to exchange insights and knowledge with other students or the rest of the class.

### Final remark

Our aim is not to work exclusively with inquiry-based tasks or problems. Sustainable results are achieved only when we have a balance between instruction (provided by the teacher) and independent construction. Routine tasks still retain their importance for practising or inculcating certain procedures, patterns, or skills. Inquiry in mathematics classes means asking questions and seeking answers, recognising problems and seeking solutions. Inquiry-based situations also allow students to show whether they are in a position to apply the knowledge they have acquired.

---

\* for more details see also <sup>2,6</sup>

## References

- 1 Artigue, Michèle: What is Inquiry-Based Mathematics Education (IBME)? In: Artigue, Michèle and Peter Baptist: Inquiry in Mathematics Education, Fibonacci Background Resources, Bayreuth/Paris 2012
- 2 Baptist, Peter: Experiencing Mathematics. In: Baptist, Peter, Carsten Miller, and Dagmar Raab (eds.): Towards New Teaching in Mathematics, Issue 4, Bayreuth 2011, <http://sinus-international.net> (last visited 09/05/2012)
- 3 Baptist, Peter: Simplify Mathematics Education. In: Baptist, Peter, Carsten Miller, and Dagmar Raab (eds.): Towards New Teaching in Mathematics, Issue 7, Bayreuth 2011 <http://sinus-international.net> (last visited 09/05/2012)
- 4 Everything is number – sometimes irrational. DVD (in German, English, Turkish), MedienLB, Gauting 2011
- 5 Baptist, Peter: Towards Teaching and Learning Inquiry-Based Mathematics. In: Artigue, Michèle and Peter Baptist: Inquiry in Mathematics Education, Fibonacci Background Resources, Bayreuth/Paris 2012
- 6 Becker, Jerry P. and Shigeru Shimada: The open-ended approach: A new proposal for teaching mathematics. NCTM 1997
- 7 Boaler, Jo: What's math got to do with it? Penguin Books, New York 2009
- 8 Devlin, Keith: The Language of Mathematics. Freeman and Company, New York 2000
- 9 Devlin, Keith: The Man of Numbers. Fibonacci's Arithmetic Revolution. Walker & Company, New York 2011
- 10 Du Sautoy, Marcus: The Music of the Primes. HarperCollins Publishers, New York 2003
- 11 Flewelling, Gary and William Higginson: Teaching with rich learning tasks. AAMT 2005
- 12 Hardy, Godefrey H.: A Mathematician's Apology. Cambridge University Press, Canto edition 1992
- 13 Mason, John: Learning and Doing Mathematics. OED Books 1999
- 14 Polya, George: How to Solve It. Princeton University Press, Princeton and Oxford 2004 (first published 1945)
- 15 Schoenfeld, Alan H.: Polya, problem solving, and education. Mathematics Magazine, Vol. 60 No. 5, 1987
- 16 Schoenfeld, Alan H. and Alan H. Sloane (eds.): Mathematical thinking and problem solving, Routledge 1994
- 17 Singh, Simon: Fermat's Last Theorem. HarperCollins Publishers Limited, 1997
- 18 Thomas, Douglas and John S. Brown: A New Culture of Learning. CreateSpace 2011
- 19 Ziegler, Günter M.: Mathematics School Education Provides Answers – To Which Questions? Newsletter of the European Mathematical Society, Issue 84, 2012
- 20 Donovan, M. Suzanne and John D. Bransford (eds.): How Students Learn: History, Mathematics, and Science in the Classroom. The National Academic Press, 2005
- 21 Rowland, Tim and Kenneth Ruthven: Mathematical Knowledge in Teaching. Mathematics Education Library, Springer 2011

<sup>22</sup> Courant, Richard and Herbert Robbins: What is Mathematics? An Elementary Approach to Ideas and Methods. Oxford University Press, 2<sup>nd</sup> edition, 1996

## Photo Credits

Fig. 1: Hardy's Taxi, ©Eugen Jost, Thun

Fig. 2: Mediterranean Geometry, ©Eugen Jost, Thun

Fig. 3: Girasole, ©Eugen Jost, Thun

Fig. 4: Sunflower (Helianthus) created by 3268zauber, Wikimedia Commons under license CC-BY-SA-3.0

Fig. 5: Sunflower with 34 and 55 Fibonacci spirals created by Dr. Helmut Haß, Wikimedia Commons under license CC-BY-SA-3.0

Fig. 6: Contemporary portrait of Fibonacci by unknown medieval artist, Wikimedia Commons public domain

Fig. 7: Copyright by Wikimedia Foundation, Inc.



# 2 The Basic Patterns as Key Aspects of Inquiry Pedagogy

---

## 2.1 The concept of basic patterns

*Dagmar Raab*

The Fibonacci project is based on the FP 7 call of the European Commission (EC) inside the work programme “Science in Society”. The EC required some details that had to be included: “... greater emphasis needs to be placed on the development of more effective forms of pedagogy; on the development of analytical skills; and, on techniques for stimulating intrinsic motivation for learning science, taking into account various pre-conditions and cultural differences.”

Therefore, the concept of the Fibonacci project had to be very flexible, with room for national and/or regional specifications. On the other hand, the EC named strictly obligatory components of the project structure:

*The training of the teachers should include actions that contribute towards the following: Securing basic knowledge, developing a task culture, learning from mistakes, cumulative learning, autonomous learning, experiencing subject boundaries and interdisciplinary approaches, differentiating between girls’ and boys’ interests, and promoting pupils’ cooperation.*

How can we deal with this apparent contradiction between flexibility and restrictions?

### 2.1.1 Basic patterns as an underlying core structure

In analogy to the successful module concept of the German SINUS-Transfer programme, we decided to use nine basic patterns as an underlying core structure of the Fibonacci project.

1. Developing a problem-based culture.
2. Working in a scientific manner.
3. Learning from mistakes.
4. Securing basic knowledge.
5. Promoting cumulative learning.
6. Experiencing subject boundaries and interdisciplinary approaches.
7. Promoting the participation of girls and boys.
8. Promoting student cooperation.
9. Promoting autonomous learning.

Of course, this array of problem areas didn’t just appear from nowhere; it is based on many years of international educational research and empirical studies.

### 2.1.2 What is special about this overarching concept?

Many projects for professional development of teachers use the top-down approach: Ready-made training units, often dedicated to a specific topic, are offered in isolated training seminars not taking into account the individual daily problems and needs.

An effective change of teaching methods will be most successful if the teachers accept the innovation process and are capable of integrating the changes in their curriculum. Instead of stand-alone training, in-service training should be incorporated into a professional, classroom-related development structure that focuses on continuous development and takes into account the demands of daily classroom teaching <sup>1</sup>.

In the Fibonacci project, teachers are seen as experts in teaching and learning who are capable and responsible for further developing and improving their own classroom teaching. Using the “basic patterns” they can frame their work, but also share their thoughts and ideas with their colleagues. As learners in the project, teachers are seen as “reflective practitioners” <sup>2</sup> who work in a self-directed and cooperative way.

Teachers, together with their in-house mathematics or science department or a regional set of involved schools, decide which of the deficits in actual science and mathematics instruction described by the basic patterns they want to address in their work. Training sessions typically start with a brief introduction to the pattern-specific ideas and their research base. A main focus, however, is to offer innovative examples that can be adapted and modified to specific classroom situations and, ultimately, incorporated in new concepts. The basic idea is that teachers develop their views about good instruction by trying out new approaches and sharing their experience with colleagues at school or at the school network level <sup>1</sup>. This way of professional development also provides many opportunities to rethink their normal views of good teaching and learning. It also opens the door for international communication and exchange, using the same framework but respecting the different national requirements.

For further reading see *Towards Teaching and Learning Inquiry-Based Mathematics* <sup>3</sup>.

## 2.2 How to work with basic patterns

*Peter Baptist, Dagmar Raab*

*Dear friend, theory is all grey, and the golden tree of life is green. – Johann W. v. Goethe (1749 - 1832)*

In this short article it is not possible to go into detail about all nine basic patterns. There is plenty of material available on the Fibonacci server <sup>4</sup>, in the SINUS International portal <sup>5</sup>, and on the SINUS-Transfer website <sup>6</sup>.

We will show some examples how to work with selected basic patterns as well as point out the connections between different basic patterns.

### 2.2.1 Developing a problem-based culture

The first basic pattern plays a particularly important role in teaching mathematics. Tasks and problems are starting points of mathematics education. Problems characterise mathematics lessons as part of an introduction to a new topic or as exercises at the end of textbook chapters. If we want to change teaching and learning maths, it is essential for us to look at how we deal with problems in the classroom.

We have to distinguish several stages. To start, we have three preparatory stages:

- Exploring: Students start learning by exploring texts, materials, situations and events.
- Questioning: Students ask questions to clarify an issue or pose a problem.
- Collecting and planning: Students collect data and information. They think of a range of possibilities to answer open questions or to solve the problem.

Having a good theory is crucial, but at school it is just as important to provide the right examples to get practice in this kind of problem solving.



Here are some suitable problems for such a process:

- How much air does this hot-air balloon (Fig. 1) contain?



Fig. 1: 2006 Ojiya Balloon Festival

- A tangram puzzle consists of seven geometrical shapes (Fig. 2), so-called tans that are put together to form specific shapes. All seven pieces must be used and may not overlap. Find different tasks and problems in connection with the tans.



Fig. 2: Tangram puzzle

- The photograph shows a balcony railing (Fig. 3).

Consider the quadratic pattern in the space between two posts. Draw this pattern and write down as many tasks and problems as you can find.



Fig.3: Balcony railing

The next stages in the process are

- Deciding: Students decide which possibility provides the best answer(s) to the questions or the solution to the problem.
- Communicating: Students choose the best way to present and explain their findings.
- Looking back: Students review their solution. Does it make sense? Is there a better way? They consider extensions and variations.

Our first basic pattern, developing a problem-based culture, aims at a larger variety of tasks and problems that allows individual and different solutions at various levels. We have to create problems that

- enable students to find different ways of solving problems,
- systematically repeat content previously learnt,
- allow an open-ended approach,
- make use of a student's basic knowledge and connect it with newly acquired skills,
- can be transferred to various situations and contexts.

Furthermore, we have to use a wide variety of teaching methods and strategies when a new concept or phenomenon is introduced and elaborated, when known content is applied to new situations, and when computers are used as a learning tool.

See more examples and background information, e.g. about open-ended tasks and topics with variations on the SINUS-Transfer server<sup>7</sup> and in the *Background Resource* "Inquiry in Mathematics Education"<sup>3</sup>.

## 2.2.2 Promoting cumulative learning

"Now we have learned a lot about triangles, the tests on this topic showed quite nice results. Let's start a new chapter: Quadrangles." Does this sound familiar to you?

Most curricula prescribe a strict chronological sequence of aims and contents with a detailed approach. Students generally like to learn in single portions as it gives them the opportunity to be well prepared for the next exam. However, by learning this way students don't see the connections between things that they have already learnt and the topic that they are about to start. Thus, the acquired knowledge remains fragmented, unsuitable for solving new problems. And, at the latest after the exam to conclude the topic, they forget the material in order to make room for new things<sup>8</sup>.

So, do we need to completely change the curricula? No, chronological structured contents are not contradictory to cumulative learning processes per se.

It is more important to get students acquainted with thinking in a broader context, with persistence and courage to be unorthodox and not being afraid of failure.

### Example: Circumcircle of quadrangles

Do all quadrangles have a circumcircle?

Let's imagine for a moment that students have worked intensively on the topic of "circumcircles of a triangle" and know that there is exactly one circumcircle for each triangle (see also learning unit<sup>9</sup>).

Now the question "Do all quadrangles have a circumcircle?" could be a good starting point for reflecting and broadening the knowledge about circumcircles.

We can use an inquiry-based approach:

The students start with a brief research phase to get oriented, gather first impressions, express assumptions and discuss. Dynamic learning environments are very helpful at this stage as they enable students to visualise the problem.

However, special cases such as squares, rectangles, kites and trapeziums will quickly emerge; there is no coherent system, and special angles or parallelisms cannot be observed either. The position of the centre of the circle seems to be arbitrary, too (Fig. 4 – 7).

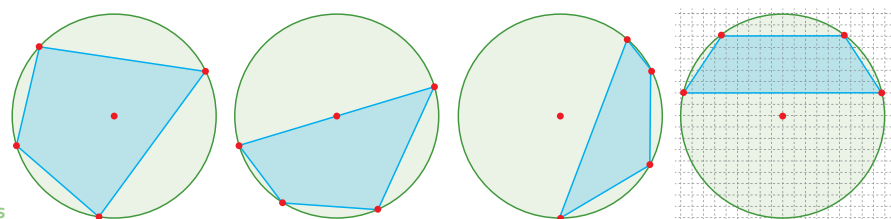

Fig. 4 – 7: quadrangles with circumcircles

Some quadrangles that probably do not have a circumcircle should be notated on a sheet of sketching paper.

Here are two examples (Fig. 8):

In everyday class situations, tasks that require entering new terrain, and accordingly more complex analyses, present considerable obstacles for students. At the outset there is bewilderment: "I don't know where to start. We haven't done any of that yet ..."

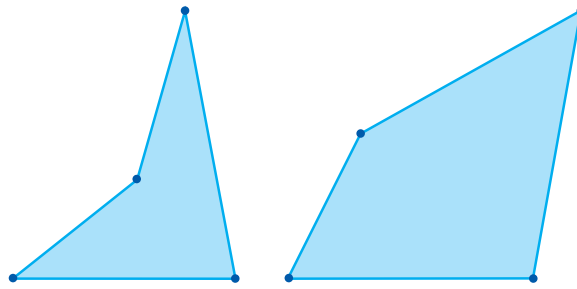

Fig. 8: Quadrangles without circumcircles

At this point, it is worthwhile to stop and take a good look at the treasures that have already been unveiled. How does the new situation differ from an already known one?

In this case, the variation of the well-known triangle is moderate: only one angle has been added.

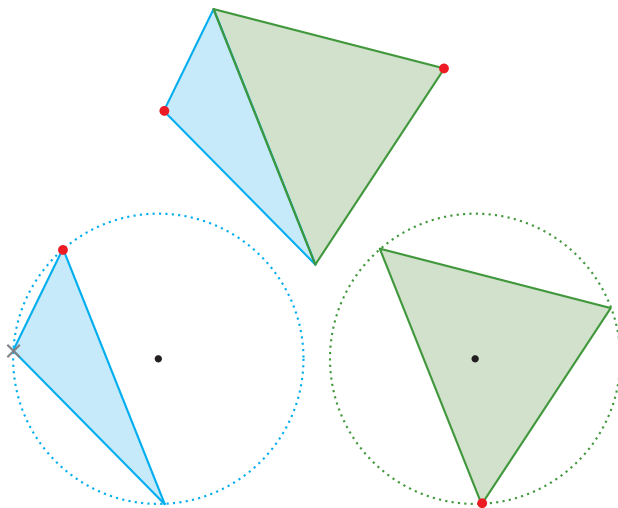

Fig. 9: Quadrangle divided in two triangles

And upon close inspection, a quadrangle can be represented as a combination of two triangles. Each triangle has a circumcircle. Now we have to use our knowledge about the circumcircle of a triangle and an answer can be found to the much simpler question: Are the circumcircles of the two triangles coincident?

A dynamic worksheet helps to recover many familiar elements in the new situation. The two triangles can be deduced from the quadrangle and analysed separately (Fig. 9). Finally, they are merged again into the quadrangle.

A more detailed description of this unit is available <sup>9</sup>.

The role of the teacher in this example can be quite different:

If the students are used to working independently, discussing with their partner or inside a small group, only a few hints may be needed. At the end, there should be a solution that would be presented by a group or a single student. Of course, there could also be a solution completely different to the above.

The teacher should lead the students more intensively in classes that are less experienced. Nevertheless, students should have enough time to deal with problems, think about relationships, tentatively use analogies, and develop hypotheses <sup>8</sup>. Besides this, students should be encouraged to write down their individual ideas, attempts and also their errors.

Teaching and learning this way helps students understand the manifold connections within mathematics, recognise and analyse logical structures, and deduce new knowledge from what they already know.

In this example we have focused on the basic pattern of "promoting cumulative learning", but obviously there are also connections to the patterns of "securing basic knowledge", "promoting student cooperation" and "promoting autonomous learning".

### 2.2.3 Learning from mistakes

***Success is the result of correct decisions. Correct decisions come from experience. Experience comes from wrong decisions.*** – Anthony Robbins (author and coach)

Wise words, but the reality is different: Most of the time, we run away from our mistakes. We don't want to think about them. It's an unpleasant experience and we feel guilty about failure <sup>10</sup>.

But as Anthony Robbins states, we cannot learn if we are not allowed to make mistakes. The fear of making mistakes prevents us from discovering the unknown. Committing mistakes in the learning environment should be a positive process, the starting point for further learning, motivation, and the quest for and discovery of correlations. With this approach we transform subordination to self-responsibility; in other words, "we transfer some of the learning responsibility to the learners themselves" <sup>11</sup>.

When we discuss the role of mistakes in the classroom, we have to consider different situations. A learning situation needs a climate in which students are "allowed" to make mistakes and to develop "wrong" conceptions <sup>12</sup>. In assessment situations, however, it is not wise for students to express wrong ideas, as they would result in bad marks.

So teachers should keep assessment situations to the bare minimum. Learning situations shouldn't give students the feeling of being under permanent control. Mistakes, whether occurring in exams or in learning situations, should never represent personal failure, but rather a challenge for the student or the whole class.

#### Working with erroneous examples

"Paying explicit attention to (mathematical) errors in class is even considered by many as dangerous since it could interfere with fixing the correct result in the student's mind. Hence, traditionally, schools mostly teach 'positive knowledge' only and 'negative knowledge' is mostly avoided." <sup>13</sup>

Indeed, students will learn best from their own mistakes if they have learned to perform effective error analysis. To get students acquainted with error analysis it is very helpful to start with erroneous examples, not necessarily ones produced by the student himself or his classmates. Erroneous examples give the opportunity to learn about different error types, to find the reasons that have led to errors, and to draw conclusions from them. In addition, some students will increase their self-confidence by analysing and correcting somebody else's errors instead of being confronted with their own misconceptions.

For more information on this topic, see the articles by Erica Melis <sup>13</sup> and Michael Katzenbach <sup>14</sup>.

#### From error to knowledge – circumcircles and inscribed circles

***I have not failed. I've just found 10,000 ways that won't work.*** – Thomas Alva Edison (1847 - 1931)

Let's go back to the example of circumcircles and start a new investigation:

***Does every quadrangle have an inscribed circle?***

As we know every triangle has exactly one circumcircle and an inscribed circle as well. So it seems as if the inscribed circle of quadrangles will be quickly revealed.

But careful: not every analogous conclusion will lead to the goal.

An attempt to return to the familiar inscribed circle of the triangle by triangle decomposition will fail as Fig. 10 shows.

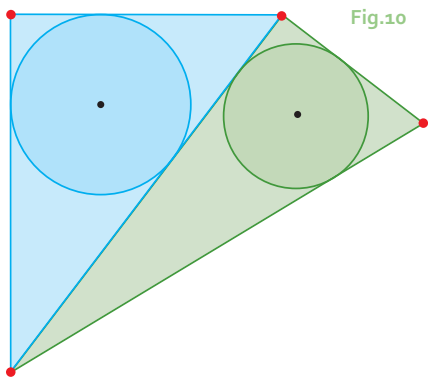

Fig.10

So should we throw away this first attempt and start from scratch again? Let's go the other way and examine this obvious aberration first. At least it provides a good opportunity to develop strong argumentation skills.

We easily see some first results: In Fig. 10 each of the two circles only touches two sides of the quadrangle. Both of the circles touch the diagonal line inside the quadrangle.

Yet the idea to seek a solution by means of two triangles does not seem absurd. If we can manage to work in analogy to the circumcircle, we should try to find triangles that have all three sides in common with the quadrangle.

Again, a dynamic worksheet is helpful. The quadrangle can be remodelled in multiple ways into a triangle by placing three vertices on a straight line (see Fig. 11 and Fig. 12) in each case.

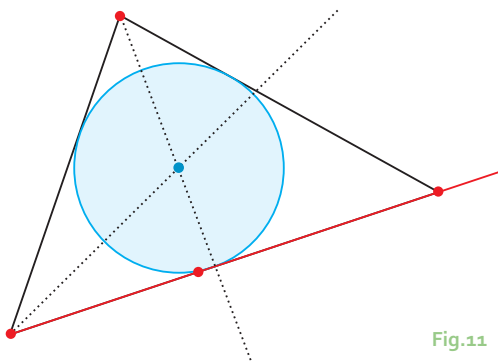

Fig.11

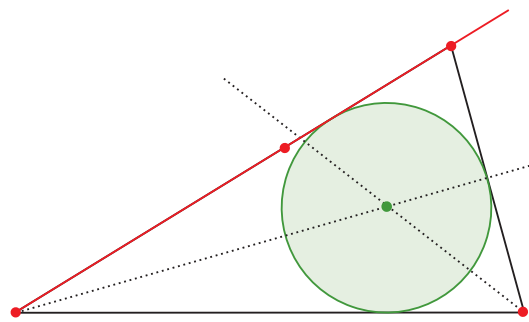

Fig.12

Now finding the analogous conclusion about the inscribed circles of the triangles becomes much easier.

In Fig. 13 we see two triangles around a common inscribed circle. When overlaying those two triangles you get a quadrangle with an inscribed circle.

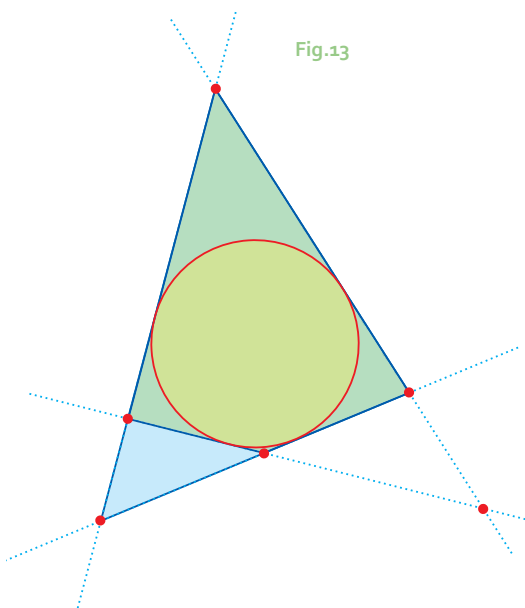

Fig.13

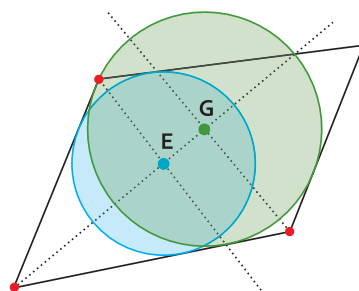

Fig. 14 Quadrangle without a circumcircle

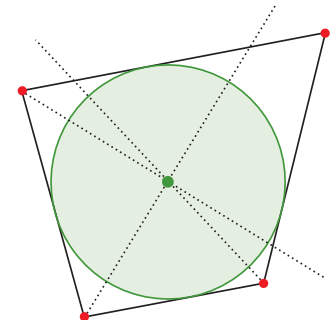

Fig. 15 Quadrangle with a circumcircle

Paul H. Schoemaker formulated a good result of this chapter:  
**Not making mistakes may be the greatest mistake of all.**

## 2.2.4 Experiencing subject boundaries and interdisciplinary approaches

Interdisciplinary teaching is not something new. Many curricula include mandatory instructions for interdisciplinary classes in all academic years and school types. However, interdisciplinary phases are frequently not yet integrated into the “regular” lessons. Mostly they take place in the form of project days held once in a school year – often at the end of a longer learning section, before the holidays or the end-of-school report. As these projects are clearly separated from the usual lessons, their outcomes mostly remain isolated and don’t result in sustainable effects.

The strict limitation of the subjects in everyday teaching contributes to the fact that many pupils do not succeed in correlating what they learn with their everyday life and existing knowledge. Newly acquired knowledge is compartmentalised and remains reusable only in a restricted scope. This is intensified by uncoordinated juxtaposition and duplication of items all the way to contradictory explanation of the same topic in different subjects.

### An interdisciplinary lesson

Algebra is an important topic in mathematics curricula in secondary schools. The following example gives insight into the role of functions in physical problems as well as into the opportunities to better understand the mathematics behind such problems. The point of view will change several times, from the mathematical to the physical aspect.

We start with a mathematical question:

How do the parameters **a**, **b**, **c**, **d** influence the graphs of the family of trigonometric functions

$$f(x) = a \sin[b(x + c)] + d?$$

A dynamic worksheet helps students observe the possible variations (Fig. 16).

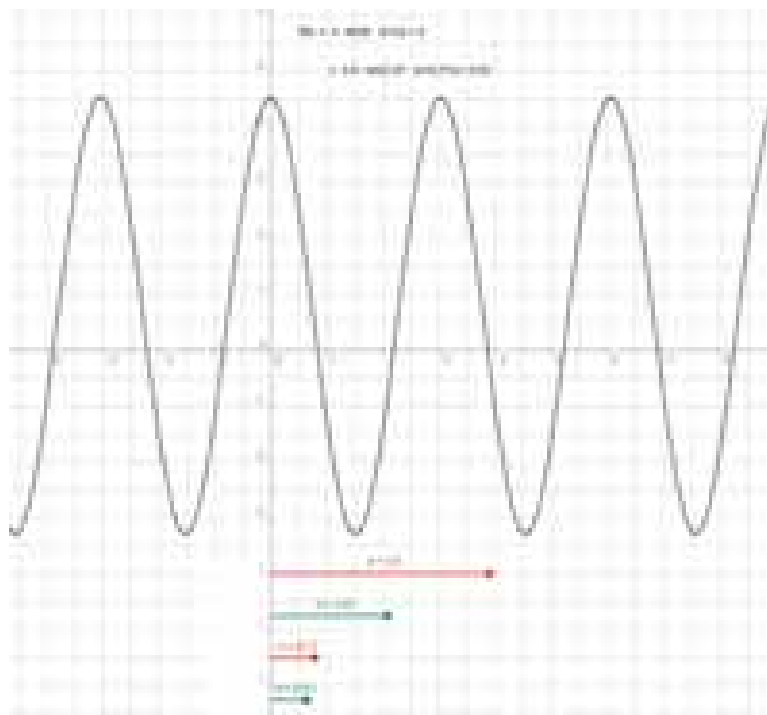

Fig. 16

The students will certainly find out the effects of the parameters, but do they really understand what they see? How can they keep it in mind and make use of it in other contexts?

A rich variety of physical examples can bring deeper understanding.

Let’s change the point of view and look at some experiments about harmonic oscillations. In this case, it could be helpful to work together with a colleague (or teacher student) who is an expert in physics, at least to prepare the experiments. Mechanical oscillations and especially sounds are very motivating and interesting for students, as they can analyse, research and learn using multiple senses.

Now the parameters come alive and are named as amplitude, frequency, and shift. The variable (in mathematics mostly named  $x$ ) should be renamed into  $t$  as it represents time. We also recognise that the parameter  $c$  isn't needed yet. Shift will also be ignored for the most part in further investigations. This procedure is also interesting from a mathematical perspective: Irrelevant parameters are eliminated, which means setting their value to zero (summand) resp. 1 (factor).

We go back to the physical aspects: In reality, free oscillations don't look like Fig. 16 because they are damped. Using some experiments we can find out the change: The amplitude isn't constant any more, but time dependent and becomes zero after a while.

For further investigations, we need a model that could describe damped oscillations in general. This is a good time to go back to the underlying mathematics.

We know that we have to modify the amplitude (respective the parameter  $a$ ). From a mathematical perspective, this means changing the constant  $a$  to a time dependent function  $a(t)$ . Let's use the simple function  $f(t) = \sin(t)$  for the undamped oscillation. In this case, our function for the damped case looks like  $d(t) = a(t)\sin(t)$ . The amplitude function  $a(t)$  is unknown at this stage of exploration. How can we find an adequate function  $a(t)$ ?

There are many ways to continue. Let's use trial and error, starting as simply as possible.

We decide to give the students a dynamic worksheet, which looks very promising offering a ready-made function (Fig. 17).

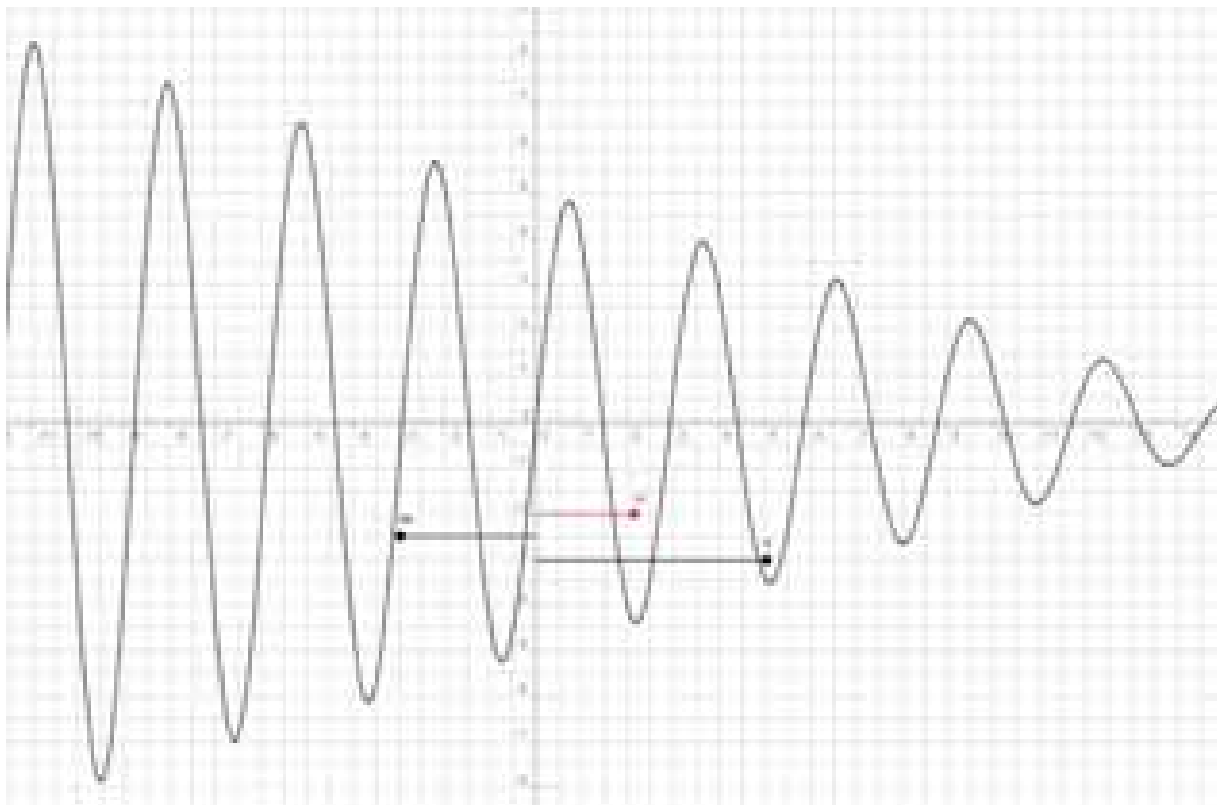

Fig. 17

We stay in the "mathematics mode": Could this be a good solution for our function  $a(t)$ ?

There are some characteristics that are obviously met: The function is decreasing with limit zero, periodic and reacting adequately when the frequency is varied.

At first glance, this function seems to be a good solution ...  
until some students find out something strange (Fig. 18):

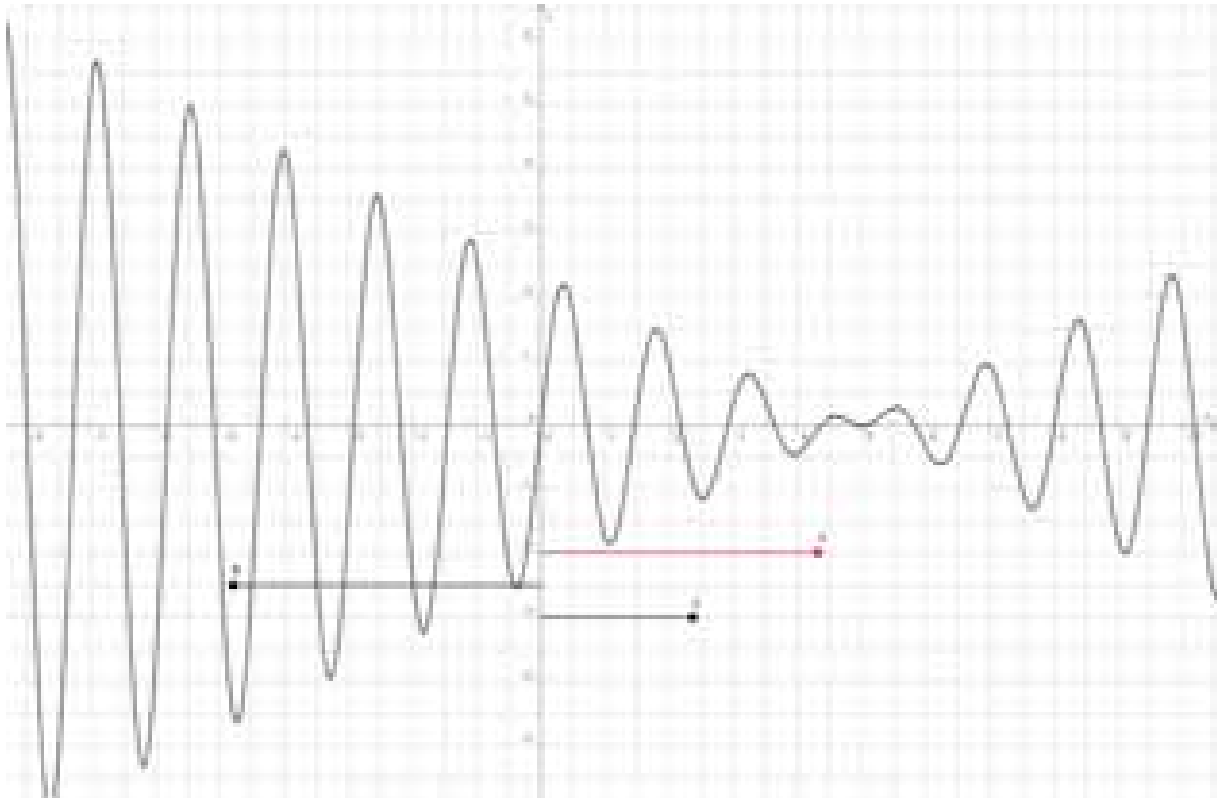

Fig. 18

There should be an intensive discussion about the underlying mathematics as well as about possible physical phenomena. If we make use of a ruler, we can easily find the (mathematical) solution (Fig. 19):

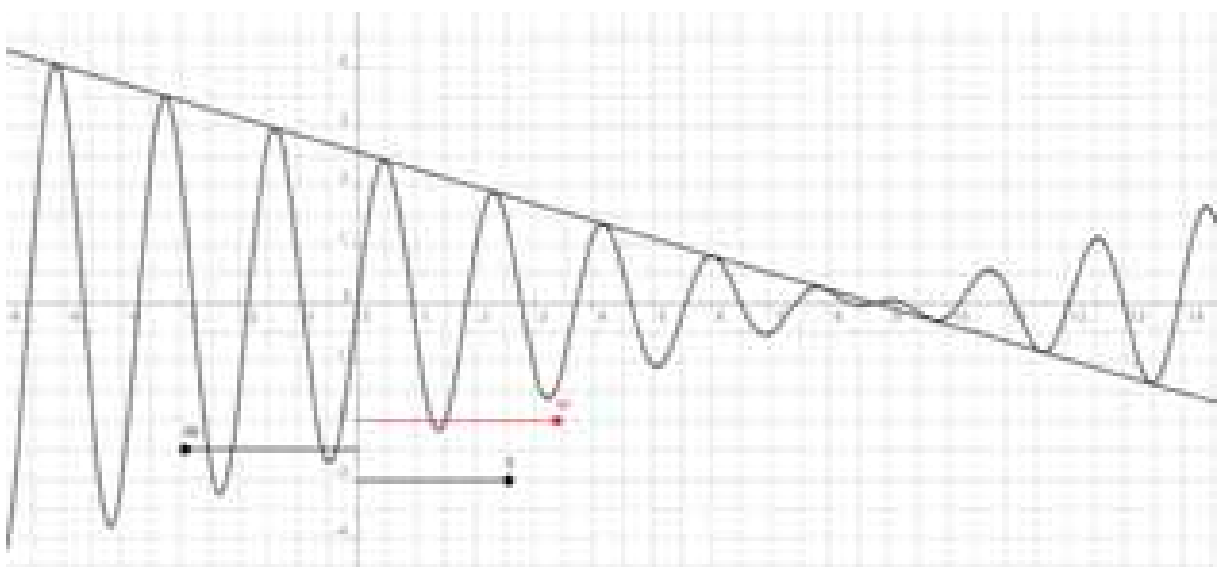

Fig. 19



How you find an exponential function as a proper solution is up to you and your students.

Obviously, this unit can be done in regular lessons as the topics trigonometric functions and oscillations should mostly be part of the official curricula. Switching from mathematics to physics and back again can foster understanding in both subjects: The way of modelling a real-world phenomenon is done step by step, while the underlying mathematics becomes meaningful, alive, and ultimately more interesting and motivating.

To develop cross-disciplinary approaches, teachers must first overcome their subject boundaries. Working in teams that integrate teachers from other subjects could be a good way to deepen knowledge and create new perspectives.

The example above also has strong connections to other basic patterns such as *learning from mistakes*, *securing basic knowledge*, and *promoting cumulative learning*.

These few examples should provide a basis for discussions in teacher trainings and provoke thought for own ideas.

## 2.3 Dialogic learning – from an educational concept to daily classroom teaching

Translated from: "Dialogisches Lernen. Von einem pädagogischen Konzept zum täglichen Unterricht", Grundschulunterricht Mathematik, 02-2010 (Mai), Oldenbourg Schulbuchverlag, translated by Mike Rohr

*Peter Gallin*

**The development of the concept of self-controlled and sustainable learning is based on a personal encounter between two teachers of entirely different subjects. Two examples show how uncomplicated teaching mathematics in the classroom can be, once the teacher has gained the courage to trust in the capabilities of the children. The three textbooks "Ich – Du – Wir" ("I – You – We") for German and mathematics in the first six years of elementary school provide support.**

With our publication *Dialogisches Lernen in Sprache und Mathematik* ("Dialogic Learning in Language and Mathematics")<sup>22</sup> over ten years ago, Urs Ruf and I attempted to pool the wide variety of experience we had ourselves gained as Gymnasium (high school) teachers as well as that from colleagues of all school levels we met in our further training courses. Thus we tried to develop a uniform teaching concept we now call *dialogic learning*. These practical educational reflections, which extensively took place parallel to our teaching work at high school and remote from empirical educational research at universities, met with a satisfying response in German-speaking regions and have in the meantime become established in the scientific community. This was largely due to a shift in our focal points to the University of Zurich, which also freed our concept from the initial bond with the grammar school subjects of German and mathematics. Nonetheless, the essence of *dialogic learning* still focuses directly on practical classroom activities and on a realistic, efficient time and effort management for all persons involved in the lessons. To ensure that the concept can also be implemented at primary school level, we additionally developed "I – You – We" textbooks for German and mathematics for the first six years of school, which are used here and there as teaching aids officially approved in the canton of Zurich<sup>18, 21</sup>. This section will, on the one hand, present *dialogic learning* in a concise framework and, on the other, provide pointers to the – by its nature free – use of the "I – You – We" schoolbooks.

### 2.3.1 Genesis and theory of dialogic learning

Over many years, *dialogic learning* was developed through dialog in a constant process of critical analysis of classroom teaching practices. The foundation was laid in the 1970s in the framework of interdisciplinary coope-

ration at the Kantonsschule Zürcher Oberland in Wetzikon, Switzerland. Urs Ruf, a teacher and professor of German, and I, a mathematician, were looking for points our two subjects had in common. We quickly realised that although there are overlaps, they are not of primary importance for high school teaching. Our cooperation rapidly shifted to the basic problems that students repeatedly have to master in our school subjects. By a stroke of luck, it turned out that Urs still had lasting memories of his own mathematics lessons at high school – not all of them of a positive nature. As far as my German lessons at school were concerned, I had endured a similar experience. This constellation enabled us to analyse the process of learning in these two subjects without having to take into account common topics. Our interdisciplinary cooperation, which we then called “overlapping” instead of merely “touching”, was characterised by the following approach: Whenever we examined a topic involving either German or mathematics, the one who had majored in the subject took on the role of an expert, the other the role of a novice. In this way, the respective teacher had a student to deal with, who was interested in the unfamiliar subject and willing to learn, but was also able to clearly indicate and articulate his difficulties.

A concrete example from the beginning of our cooperation serves to illustrate how the didactic dialog between us took place. What you need to be aware of at this stage is that I have always had a special interest in games of logic and brainteasers ever since my university student days. At that time, I did not realise their didactic significance - in contrast to the didactic significance of the specified syllabus for mathematics. Intuitively, I liked confronting others with such problems because, as a general rule, the people concerned could not simply fall back on a formula or predefined procedure to solve the problems. One of the characteristics of brainteasers is, therefore, that they reveal the one-dimensional image of mathematics that many people have. They think that mathematics is a science that consists of exercises and questions for which a solution can always be found by means of formulas (algorithms) that have to be learned. Today, we call this restricted (one-dimensional) view of mathematics a “mathematical injury” (Fig. 20). Unfortunately, even today mathematics instruction rarely manages to convey a differentiated view of mathematics. This, however, is precisely the aim of *dialogic learning* in mathematics as a school subject.



Fig. 20: A restricted (one dimensional) view of mathematics: the mathematical injury

During our first didactic dialog, I was of course unaware that Urs had been made a victim of this mathematical injury in his former mathematics lessons, to the extent that he believed he had to answer every mathematical question immediately with a formula. This is why he felt great distress when I described an authentic problem I was faced with while filling the tank of my car. As he later admitted to me, his first inner reaction to my story was: “What algorithm, what formula do I have to use to solve the problem as quickly as possible?” But he didn’t let it show, of course. As a Germanist, he had learned that attack is the best form of defense. Consequently, he protested, “What you’re telling me here isn’t complete at all. To me it sounds like one of those word problems where the author struggles through a story, but doesn’t disclose the crucial part and beats around the bush. If he were to reveal it, the problem would no longer be of any interest.” When I denied having withheld any information, he retorted, “OK, I’ll prove it to you. I’ll write down everything you’ve told me or better yet: the way I have understood it.” No sooner said than done. When I read his text, I exclaimed, “Something is missing here!” It was, of course, a great triumph for him. “That’s exactly what I wanted to prove”, he answered. But I didn’t relent, didn’t reproach him and took a closer look at his text. I rewrote it and gave him the new version to read. Then he said, “Now I don’t understand the story anymore.” He rewrote the story again, after which it became my turn to declare, “Now the problem can no longer be solved.” The story went back and forth in this manner several times until we both agreed on the version that resulted from this written dialog. Satisfied with the text, we unfortunately threw away all the previous versions. Today it would be interesting to retrace this

development process once again. At the time, we were, however, only interested in the final result, which was to become part of a small book we had decided to publish. For this booklet we jointly formulated fifty puzzles from my collection word by word, sentence by sentence, as in the first story. It was then published in 1981 by Silva-Verlag Zurich under the title *Neu entdeckte Rätselwelt* ("Newly Discovered World of Puzzles")<sup>16</sup>. The first story described above was included as problem no. 17, which carried the title "While Filling the Tank."

I had parked my car in front of one of the many gas pumps at a shopping center. A green light showed me that it was available for use. It was a self-service filling station. When a customer has finished pumping gasoline, a red light on the pump lights up showing that it is now blocked. The customer takes the receipt printed by the machine and goes to the cashier, who supervises the entire filling station. Once the customer has paid, the cashier unblocks the respective pump from a central control panel. When I lifted the nozzle, I noticed the display had already been reset to zero. I filled the tank, read off how much gasoline I had put in and took the receipt from the machine. Without taking a closer look at it, I went to the cashier, handed over the ticket and wanted to pay. The cashier then exclaimed: "Now it's happened!" He went to the pump and came back with a receipt showing the right number of liters and the invoice in Swiss francs. What was on the first receipt? Can you reconstruct the incident?

Intensive analysis and persistent formulation attempts enabled Urs repeatedly to come up with solutions for maths problems he was faced with. This happened almost incidentally, not because he had a formula to fall back on, but because he successfully thought his way through the situation underlying the problem. What took place here can be represented in our diagram by the additional "I", which symbolises the position of Urs (Fig. 21).

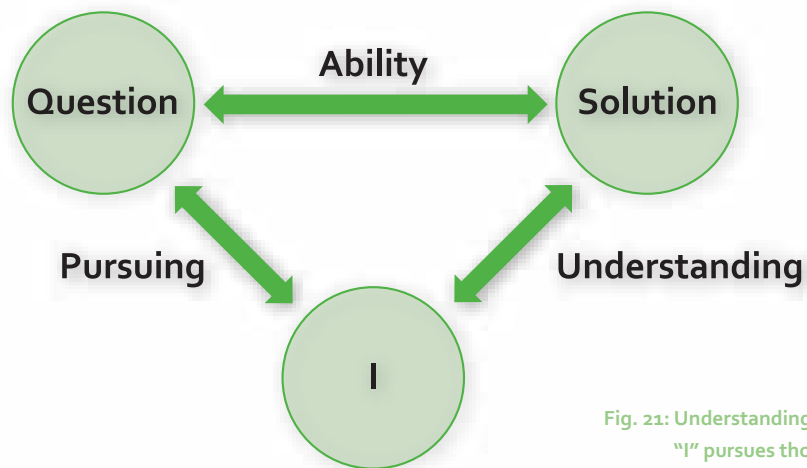

Fig. 21: Understanding is only possible if the "I" pursues thoroughly a question

Urs' encounter with the problem has two characteristic features:

1. The "I" of the learner was evidently activated by my provoking question, and
2. Urs was able to get a hold on the problem through his spontaneous writing.

We call the interaction between question and I "pursuing mathematics". Initially, the focus is thus not on solving the problem, but on exploring the question and related aspects at depth until the question becomes a genuine question for the student himself/herself. It is a well-known fact that parroting the wording of a question by no means constitutes a real question that students would actually ask themselves. So in the process of pursuing mathematics, you literally ignore the solution. And a decisive point for us here is that you speak or write in your

own language, your native language or - as Martin Wagenschein calls it - the language of understanding, not in some technical jargon or in the arcane lingo of insiders, of people who have already understood<sup>23</sup>. It has often been my experience that intensively “pursuing” mathematics leads students to the solution without their even becoming aware of it. It was the same with Urs. I had to tell him several times that he had already found the solution and could stop turning over the question in his mind, pursuing mathematics. It turned out that as a linguistic expert something completely different fascinated him from what I had anticipated on the basis of my own subject-related expectations: it was not the concentrated, unambiguous, and apodictic solutions for our problems, but the entire mathematical landscape surrounding the problem that actually captivated Urs. What interests him is how to successfully relate the question to one’s own world and to make the most of various approaches to the mathematical result. The third link in our diagram, the “understanding of mathematics”, is thus generated quasi automatically if mathematics has been pursued long enough. This experience is supported by a statement made by philosopher Hans-Georg Gadamer, in which he specifies a necessary condition for understanding: “The very first stage in the process of understanding is when something appeals to us: that is the paramount of all hermeneutic conditions.”<sup>15</sup>.

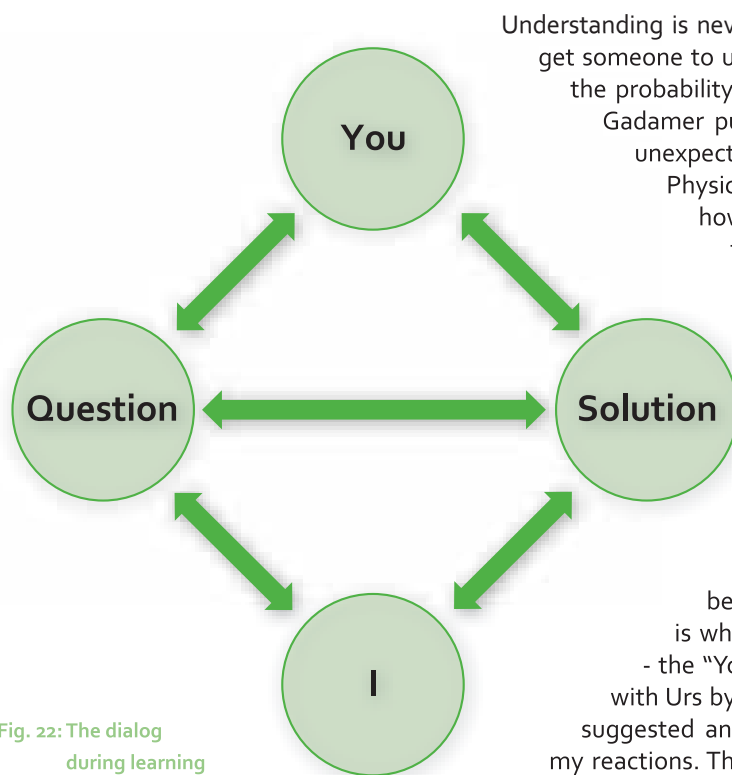
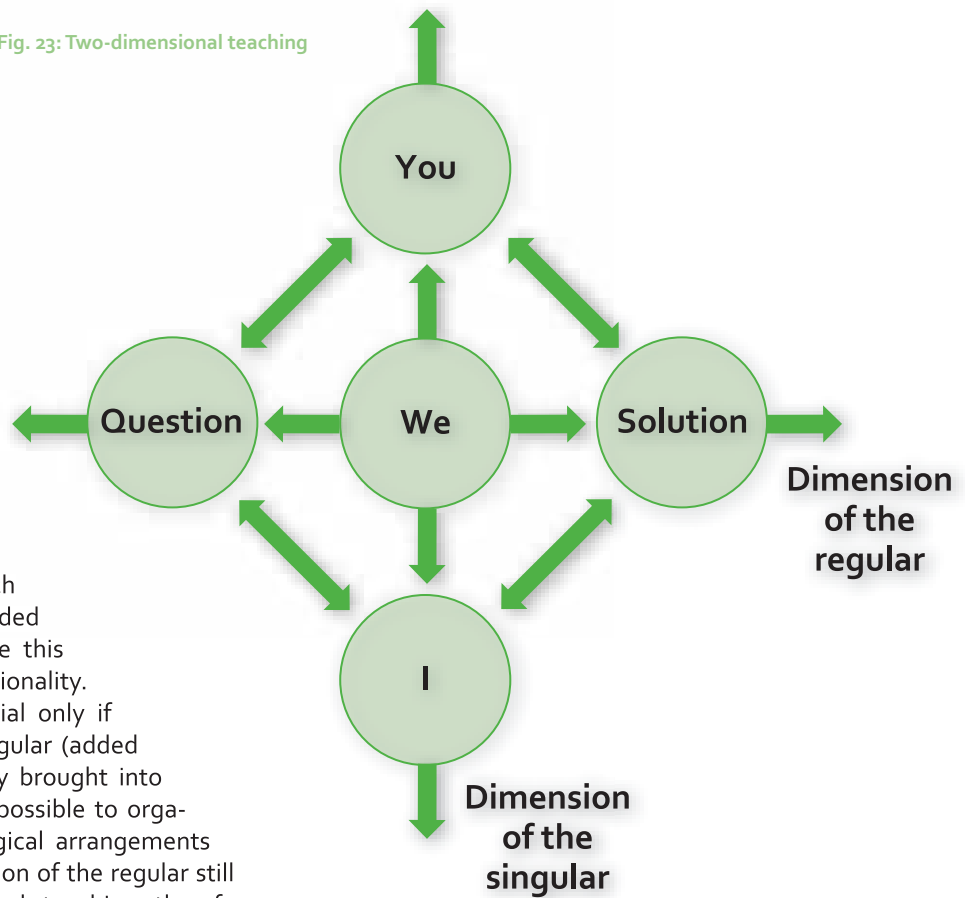

Fig. 22: The dialog during learning

Understanding is never in the hands of the teacher. You cannot get someone to understand, all you can do is try to increase the probability that the student will feel the “appeal”, as Gadamer puts it. Understanding always comes about unexpectedly, it cannot be planned and organized. Physicist Martin Wagenschein also asked himself how understanding comes into being and made the following observation: “Real understanding is brought about by talking to others: based on and stimulated by something enigmatic, looking for the reason.”<sup>24</sup> For him, too, it all starts with a person’s consternation over an “enigma”. But an additional factor comes into play here, i.e. an exchange with other people who have also given thought to the same problem. This aspect has not yet been taken into account in our diagram, which is why we extend it to include a fourth position - the “You”. This was the role I played in the dialog with Urs by responding to the solutions he tentatively suggested and raising new “questions” in him through my reactions. The dialog that develops between an I and a You in the learning process via the questions and solutions for a problem is made graphically visible (Fig. 22).

Now the one-dimensional classroom instruction, which is solely limited to teaching formulas and algorithms (horizontal direction), has become a two-dimensional form of teaching, which includes the vertical dimension between the positions I and You. The connections between the two positions opposite each other intersect at a point that we designate as “We.” That is where the regular perceptions of science meet the singular insights that develop in the dialog between the I and the You (Fig. 23).

Fig. 23: Two-dimensional teaching



I would like to make it mandatory for extended forms of teaching, which are greatly recommended nowadays, to incorporate this feature of two-dimensionality.

To me, they are beneficial only if the dimension of the singular (added to the regular) is actually brought into play. It is, after all, very possible to organise modern methodological arrangements in which only the dimension of the regular still counts. Genuine extended teaching therefore means classroom activities in which an exchange or dialog between an I and a You aimed at negotiating and defining the established regularities of the subject plays a major role, reaching all the way to the assessment and the awarding of grades [22, vol.2, p. 81ff](#). Consequently students have the opportunity at school to find out how all formulas, norms, prescriptions, rules, and algorithms that exist – not only in mathematics – are, in the end, the result of a dialog, i.e. represent binding rules as a negotiated We position. Let us be clear in our minds about the fact that particularly in science all norms and substantiated results are ultimately the outcome of a dialog, an agreement among experts.

By renaming the five positions in [Fig. 23](#), which is inspired by the individual learning and research situation, a final illustration will now show how teaching entire classes can be set up. At the same time, methodological references emerge that are typical of *dialogic learning*. At the beginning, there is not simply a question in its question form, but a provocation that induces the student to act on the factual level by means of an assignment. We call this the core idea. Through this core idea, the question is presented in a compact, attractive, and perhaps even provocative manner. The core idea is the guideline for preparing an assignment directed at all "I's" in the class. To make it possible to handle an entire class with all its heterogeneity, students are instructed to record the steps they take in tackling the assignment (learning journal or "travel diary"). These are the students' tentative "solutions" that are read by a You. Frequently this will be the teacher, but it is also entirely conceivable that other students might take a look at it beforehand and comment on the work others have done in their journals (by leaving the journals and changing places with others) [22, vol.1, p. 39ff](#). A decisive factor for *dialogic learning* is that the You provides (brief) feedback and thus acknowledges the students' core ideas that were actually effective in handling the assignment. It is perfectly possible for the students' core ideas to differ from that originally stated by the teacher. Further lessons receive new impetus from a suitable selection of the ideas found in the students' notes and a discussion of these ideas in the entire class. In *dialogic learning*, the norms that ultimately have to be learned in the subject concerned are hinted at rather than spelled out: they correspond to the We position, i.e. the target (crossing) between an I and a You at the end of the exchange.

### 2.3.2 Working with "I – You – We" as a teaching aid

The outline of the above theory and the numerous specifications involved in *dialogic learning* may put off teachers and make them think that superhuman powers are needed to meet all these requirements \*. For this reason I would like to use an example to provide suggestions for putting *dialogic learning* into practice with the help of the textbook "I – You – We" as a teaching aid and try to show that significant results can be achieved even with very small steps \*\*. The first contact with multiplication is involved here and we follow the stages in the cycle shown in Fig. 24.

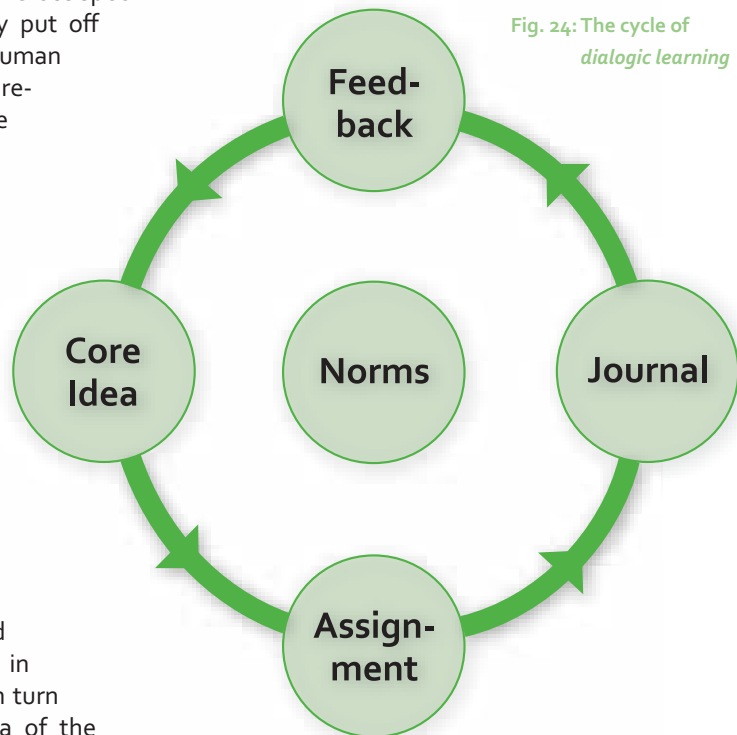

#### 2.3.2.1 Core idea

A rather broad definition of the core idea states that "Core ideas have to be phrased in such a way that they arouse questions in the singular world of the student, which in turn direct attention to a certain subject area of the lesson." <sup>17, p. 37</sup> The crucial element of a core idea is thus its effect on the student; it triggers productivity. In this function, therefore, a verbal form of a "core idea" is, strictly speaking, initially just a "candidate for a core idea" since its effect has yet to manifest itself in a specific lesson. Consequently, core ideas cannot be designated as such until later and then only in relation to a certain unique group of students. In addition to this, however, there are core ideas of teachers that have already demonstrated their effectiveness based on the particular biography and genesis of knowledge among the persons involved. And a large number of such core ideas – the core ideas of the authors and their acquaintances – are incorporated into the textbook "I – You – We" and expressed both in the main text and in the titles of the chapters and assignments. All of them relate to the official syllabus in the subjects German and mathematics and are intended to stimulate the students to grapple independently with the problem at hand via the assignments. In this way, it becomes clear what didactic role the puzzles that I employed to challenge others played: with a puzzle there is justified hope that it will act like a core idea and set a productive process in motion in the person confronted with the puzzle. Since it is not possible, however, to compress an entire syllabus into puzzles, core ideas have to take over this role.

An example that can be used in this context is the introduction of multiplication of natural numbers in the first years of school. Two core ideas are offered for this in "I – You – We 1 2 3" <sup>21, p. 62ff</sup>. The first one states: "Inner images help you to group a large number of similar objects clearly without having to touch them." The second one is: "When you put on the multiplication glasses, you see multiplication calculations all around you." It is highly unlikely that any core idea candidate will unfold its effect in school in this abstract form. For this reason, core ideas have to be transformed into specific assignments given to the students as mandatory tasks.

\* A detailed description of the approaches to a dialogic structure of classroom teaching can be found in my contribution in <sup>19</sup>.

\*\* Another detailed example from a 6th grade class (6. Primarklasse) of Patrick Kolb in Steinhausen can be found in my contribution on the rule of three in <sup>20</sup>.

### 2.3.2.2 Assignment

The teaching aid always makes an initial suggestion for an assignment that is divided into several stages and becomes increasingly complex. Practice has shown that it is advantageous to hand out only part of the assignment at a time, either as a copy or by dictating it, so it is noted in the journal (diary) immediately prior to being worked on by the school children. This makes reading easier, particularly at a later stage and for third parties. The first part of the assignment "Multiplication glasses" is: "Imagine that you are wearing multiplication glasses and look around a bit in your environment. Do you discover things that are arranged nicely in groups of twos, threes, fours or fives? Make a note of them in your diary and write an appropriate multiplication calculation for them." By making cardboard "multiplication glasses" with two round, empty holes for each child, the teacher creates an amusing way of giving the glasses a concrete function and thus makes it easier for the schoolchildren to fully dedicate themselves to the task at hand.

### 2.3.2.3 Journal

The journal excerpts shown in the textbook are intended to encourage teachers and students to try a similar approach. We weren't able to predict this reliably, but surprisingly it doesn't cross the children's mind at all to copy these illustrations. They are evidently designed so personally that a natural inhibition keeps the pupils from copying them. The following example (Fig. 25) of eight-year-old Joana, which took place recently in a normal class in Zürich-Nord at the end of the first year in primary school, shows at a glance, despite the few words used, that Joana has already understood the nature of multiplications. Thanks to these clues, you can, so to speak, look into the child's mind! A decisive element is the fact that the teacher has the courage to expect something from the children and doesn't think she has to spell out everything herself in advance by handing out restrictive worksheets, for instance. The children in this class work using sketch pads, which additionally support the freedom of the individual product through their own lack of structure.

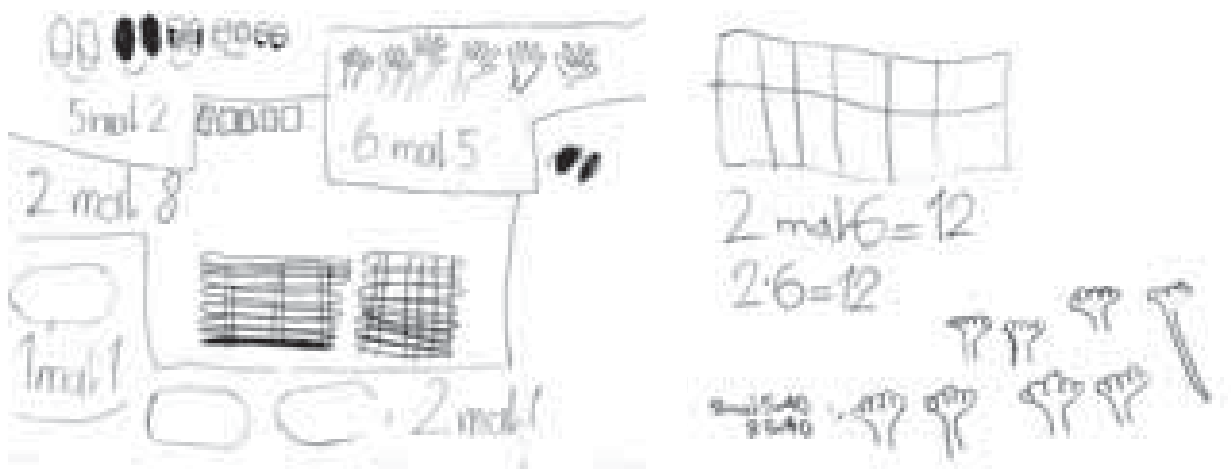

Fig. 25: With her pencil drawings Joana shows all the places where she sees multiplication calculations (the German "mal" means "times")

### 2.3.2.4 Feedback

Joana is justifiably proud of the fact that her teacher distributes her mature work in the learning journal and talks about it during a lesson. This acts as an incentive and creates a situation in which, sooner or later, even weaker students show above-average achievement relative to their standard so that their work can be discussed and appreciated within their class. However, this is only one aspect that plays a role in going through the students' work again in class. Besides that, there is always an educational aspect that is decisive for the continuation of the lesson. In all the students' works, there are one or more core ideas that can be extracted by the teacher and turned into a new assignment. As a result, the role of the first core idea given by the teacher or the textbook fades into insignificance. Furthermore, preparation for the following lesson can be carried out in the course of



looking through the students' works. Core ideas in Joana's work may include: "It is useful not to state the result of the multiplication calculation right away" or "Pictures without calculations or with a mistake may give rise to a new puzzle". New assignments could be formed on this basis and then be given to everyone in the entire class. This means, however, leaving the line of approach of the textbook for a moment, which is precisely the characteristic feature of *dialogic learning*. This kind of classroom teaching cannot be planned in detail, it develops from the contributions of the students. At the same time, the inherent problem of heterogeneity is tackled via this approach, because all children in the class repeatedly receive the same assignments, which they work on individually, albeit at varying depths and levels of intensity. Nevertheless, an exchange within a class is possible, the children can help one another and discuss things so that individualisation does not lead to isolation. Instead, it leads to social learning within subject lessons.

### 2.3.2.5 Norms

A question that repeatedly arises is whether the specified teaching goals, norms, and competencies can be achieved through *dialogic learning*. Specifically, a question frequently asked is whether subject-related topics can also be practised and tested. To the extent that the work in the learning journals is not in itself practice enough – Joana has already practised several multiplication calculations – preparing for a test can itself be transformed into an assignment. The somewhat superficial, though often very effective core idea behind this is: "I want to get a good grade." Accordingly, the teacher can give each child the assignment of inventing a problem that is as difficult as possible but nonetheless manageable and interesting at the current class level. And before you know it, the teacher is in possession of more than twenty problems that exert a very particular attraction for the students, in contrast to copies of predefined tasks. The authors are known, and the students are not even certain whether all problems are well-defined and solvable. Interesting subject-related discussions among the students are inevitable. Fig. 26 shows an example from my own teaching at the Kantonsschule Zürcher Oberland in Wetzikon, Switzerland.

In summary, we can state that it is possible to transform traditional classroom teaching into *dialogic learning* by means of three simple measures:

1. Believe in your students, and do not inundate them with prepared material.
2. Teach students to produce their own individual ideas on a central topic of the lesson.
3. Look through all journals of the students, select useful material, and only then continue with the next lesson.



Exercises relating to the distributive law, U1b, 1 November 1988		
1.	Factor out: $gcdbaef + hjkmc i - oqsrcnp + zyxcwtuv$	Claudio
2.	Calculate as elegantly as possible: $9738659667 \cdot 9738659967 - 9738659567 \cdot 9738659667 + 9738659667 - 9738659467 + 9738659667 \cdot 9738659267 - 9738659967 \cdot 9738659667$	
3.	Multiply out: $(a - b) \cdot (a - b) \cdot (a + b)$	
4.	Factor out: $a^3 + a \cdot a \cdot b - a \cdot b \cdot a - a \cdot b \cdot b + b \cdot a \cdot a + b \cdot a \cdot b - b \cdot b \cdot a - b^3$	
5.	Multiply out: $(f + x) \cdot (u - w)$	Anatina
6.	Depict in a drawing ( $49 \cdot 5$ ), with different colors as far as possible	Christian
7.	Write as simply as possible: $7a^2 - (3a^2 - a)$	
8.	Factor out and write as simply as possible: $c^2 \cdot a - b + c^3 \cdot 2c + b^2 \cdot c^2$	Martina
9.	Calculate in the simplest possible way: $243378 \cdot 243379 - 243377 \cdot 243378$	
10.	Which number has to be inserted for the placeholder so that the number pairs have the same quotient? $(x^4, x^2)$ , $(49^4, x^2)$	Sara
11.	Factor out the biggest possible factor: $4^3 + 4^2 + 4^5$	Sandra
12.	Calculate as simply as possible: $189357389562 \cdot 189359389562 - 189358389562 \cdot 189357389562$	Kaspar
13.	Calculate $(a : (m + n))(m + n)$	
14.	Calculate simply $24 \cdot 89 + 53 \cdot 119 - 36 \cdot 24 - 43 \cdot 53$	
15.	Factor out: $adam + eve - apple$	
16.	Factor out: $abcdefgh + bcdefghik - deghiklm$	
17.	Multiply out: $(a - b + c) \cdot (d + e) \cdot (f - g - h + l)$	Claudius
18.	$30003 \cdot 100 \cdot 29997 : 25 : 4$	Renate
19.	$17985 \cdot 17985 \cdot 1398 - 1397 \cdot 17985$	
20.	Multiply out: $(a + b - c) \cdot (a - b - c)$	Christof
21.	Multiply out: $(a^6 \cdot a^3 \cdot a^7 - a^6) \cdot (z^7 + 6^8 \cdot 9^9 - r^3) \cdot (v^4 + v^3 - v^2 \cdot 5)$	Sämi
22.	Factor out the biggest possible factor: $133 + u - 95 \cdot v + 38 : w \cdot 171 : x + 76 - y \cdot 114 - z$	Oliver
23.	Factorising is more difficult if the factor first has to be prepared separately: $95 \cdot p + 57 \cdot q^2$	Daniel
24.	Factor out: $279 \cdot a - 31 \cdot a \cdot b + 93 \cdot a^2$	Bettina
25.	Multiply out: $(a - b) \cdot (c - d)$	Katharina
26.	Factor out: $171 \cdot 256 - 114 \cdot 8^2$	Claudia
27.	Factor out the biggest possible factor: $396 \cdot x - 18 \cdot x \cdot y + 66 \cdot x^2$	Yvonne
28.	Factor out the biggest possible factor: $x \cdot 189 + y \cdot b \cdot 147 - a \cdot 105 + z \cdot 126$	Mike
29.	Factor out: $3^2 \cdot 3^2 - 9$	Anja
30.	The two number pairs have to have the same quotient: $(x^4, 25^2)$ , $(x^4, 625)$	Oli
31.	Simplify as far as possible: $z \cdot ((z^4 + z^3) : (z^3 + z^2))$	Röbi
32.	Factor out: $z \cdot z + z : z - z$	
33.	Calculate with the distributive law in the simplest possible way. A calculator with 8 digits is available: $45626809112100 \cdot 111125709813245$	Nadine
34.	Factor out: $(a^3 \cdot b)^2 - a^3 \cdot b^2$	Philipp

Fig. 26: Exercises regarding the distributive law, worked out by all students of a Gymnasium class (7th year of school)

## References

- 1 Ostermeier, Christian, Manfred Prenzel and Reinders Duit: Improving Science and Mathematics Instruction: The SINUS Project as an example for reform as teacher professional development. In: International Journal of Science Education 32:3, 2010, pp. 303-327
- 2 Schoen, D. A.: Educating the reflective practitioner: Toward a new design for teaching and learning in the professions. San Francisco, CA: Jossey Bass 1987
- 3 Baptist, Peter: Towards Teaching and Learning Inquiry-Based Mathematics. In: Artigue, Michèle and Peter Baptist: Inquiry in Mathematics Education, Fibonacci Background Resources, Bayreuth/Paris 2012
- 4 The official Fibonacci Website <http://www.fibonacci-project.eu> (last visited 09/05/2012)
- 5 The website SINUS international with material about the German SINUS project in English language <http://www.sinus-international.net> (last visited 09/05/2012)
- 6 The official website of the German SINUS project in English language <http://www.sinus-transfer.eu> (last visited 09/05/2012)
- 7 The website of SINUS-Transfer, chapter "Developing a task culture", <http://sinus.uni-bayreuth.de/2893/> (last visited 09/05/2012)
- 8 Prenzel, Manfred, Matthias Stadler, Anja Friedrich, Katrin Knickmeier and Christian Ostermeier: Increasing the efficiency of mathematics and science instruction (SINUS) – a large scale teacher professional development programme in Germany. Kiel 2009, [https://www.ntnu.no/wiki/download/attachments/8324749/SINUS\\_en\\_fin.pdf?version=1&modificationDate=1251384255000](https://www.ntnu.no/wiki/download/attachments/8324749/SINUS_en_fin.pdf?version=1&modificationDate=1251384255000) , (last visited 09/05/2012)
- 9 Raab, Dagmar: Round and Angular – A Theme with Variations. In: Baptist, Peter, Carsten Miller, and Dagmar Raab (eds.): Towards New Teaching in Mathematics, Issue 6, 2011, <http://sinus-international.net> (last visited 09/05/2012)
- 10 Schoemaker, Paul J.H.: Brilliant Mistakes: Finding Success on the Far Side of Failure. Wharton Digital Press 2011
- 11 Jost, D. et al.: Mit Fehlern muss gerechnet werden – Mathematischer Lernprozess, Fehleranalyse, Beispiele und Übungen. Sabe-Verlag, Zürich 1992
- 12 Oser, F.: Zu-Mutung: Eine basale pädagogische Handlungsstruktur. In: Seibert N. and H. Serve (eds.), Bildung und Erziehung an der Schwelle zum dritten Jahrtausend, München 1994
- 13 Erica Melis: Erroneous Examples as Source of Learning in Mathematics. Conference paper, 2004 [www.dfki.de/~melis/Pub/melisCelda04Final.doc](http://www.dfki.de/~melis/Pub/melisCelda04Final.doc) (last visited 09/05/2012)
- 14 Michael Katzenbach: Tracking Errors - Children as Error Detectives. In: Baptist, Peter, Carsten Miller and Dagmar Raab (eds.): Towards New Teaching in Mathematics, Issue 13, 2012, <http://sinus-international.net> (last visited 09/05/2012)
- 15 Gadamer, Hans-Georg: Vom Zirkel des Verstehens. In: Günther Neske (ed.): Martin Heidegger: Festschrift zum 70. Geburtstag, Neske Verlag, Pfullingen 1959, pp. 24-35
- 16 Gallin, Peter and Urs Ruf: Neu entdeckte Rätselwelt. Silva Verlag, Zürich 1981
- 17 Gallin, Peter and Urs Ruf: Sprache und Mathematik in der Schule. Auf eigenen Wegen zur Fachkompetenz. Verlag Lehrerinnen und Lehrer Schweiz (LCH), Zürich 1990, as well as: Kallmeyer, Seelze-Velber 1998

- 18 Gallin, Peter and Urs Ruf: Ich mache das so! Wie machst du es? Das machen wir ab. Sprache und Mathematik, 4. - 5. Schuljahr bzw. 5. - 6. Schuljahr. Lehrmittelverlag des Kantons Zürich, Zürich 1999
- 19 Gallin, Peter: Den Unterricht dialogisch gestalten - neun Arbeitsweisen und einige Tipps. In: Ruf, Urs, Stefan Keller and Felix Winter (eds.): Besser lernen im Dialog, Kallmeyer Verlag, Seelze-Velber 2008, pp. 96 - 108
- 20 Gallin, Peter: "Zwei Welten" - der Dreisatz im Dialogischen Mathematikunterricht. In: Ruf, Urs, Stefan Keller and Felix Winter (eds.): Besser lernen im Dialog, Kallmeyer Verlag, Seelze-Velber 2008, pp. 162 - 212
- 21 Ruf, Urs and Peter Gallin: Ich mache das so! Wie machst du es? Das machen wir ab. Sprache und Mathematik, 1.-3. Schuljahr. Lehrmittelverlag des Kantons Zürich, Zürich 1995
- 22 Ruf, Urs and Peter Gallin: Dialogisches Lernen in Sprache und Mathematik. Austausch unter Ungleichen. Grundzüge einer interaktiven und fächerübergreifenden Didaktik (vol. 1) and Spuren legen - Spuren lesen. Unterricht mit Kernideen und Reisetagebüchern (vol. 2). 3rd revised edition of the 1st edition 1998. Kallmeyer Verlag, Seelze-Velber 2005
- 23 Wagenschein, Martin: Physikalismus und Sprache. Gegen die Nichtachtung des Unmessbaren und Unmittelbaren. In: Schaefer, Gert and Werner Loch (eds.): Kommunikative Grundlagen des naturwissenschaftlichen Unterrichts, Beltz Verlag, Weinheim 1980, pp. 11 - 37
- 24 Wagenschein, Martin: Die Sprache zwischen Natur und Naturwissenschaft. Jonas Verlag, Marburg 1986, p. 74

## Photo Credits

- Fig. 1: 2006 Ojiya Balloon Festival created by Kropsoq, Wikimedia Commons under license CC-BY-SA-3.0
- Fig. 2: Balcony railing created by Peter Baptist, Bayreuth
- Fig. 3: Tangram set created by Nevit Dilmen, Wikimedia Commons under license CC-BY-SA-3.0

## Translation

Section 2.3 Mike Rohr, Zurich, Switzerland



## 3 IBME and ICT

---

### 3.1 The use of dynamic geometry systems (DGS) and computer algebra systems (CAS) in IBME

*Pavel Pech*

#### **Abstract**

Dynamic geometry and computer algebra systems have dramatically changed the way we teach mathematics. One main goal in teaching mathematics is problem solving, for which computers offer great potential. To solve a problem students first visualise it with DGS then by changing parameters the problem is interactively modified and geometry properties like invariant points, lines, circles etc. are recognised. Using this knowledge a conjecture is stated and classically proved or disproved. But sometimes there is no key idea available to find a proof (or the locus). The use of CAS can help in such cases. We are able to prove many such theorems using automated geometry theorem proving. This is one example of how DGS and CAS contribute to inquiry based mathematics education (IBME).

#### 3.1.1 Introduction

In basic university-level geometry courses we use both classical methods and new technologies, which contemporary mathematical software offers. To solve a problem we usually start with DGS to demonstrate a geometric situation. Dynamic features of this software allow us to state and consequently verify conjectures. This means that the conjecture is (numerically) verified in an infinite number of situations, and with a high probability we can say whether the conjecture holds or not. But numerical verification is not infallible. Therefore, rigorous mathematical proof is needed. To prove a statement we use a classical proof, if possible. We show new methods of proving, deriving and discovering geometric theorems including searching for loci of points. We demonstrate this using a few examples from elementary geometry with a focus on inquiry based teaching mathematics.

#### 3.1.2 Verification and proving theorems

Proofs in mathematics are among the most difficult parts of school curricula all over the world. Even university students have trouble with them in spite of their importance. We can use new technologies to facilitate the methods for proving theorems in schools. We describe two proof categories that can be done by computer – verification in DGS and automated (computer) proving.

### 3.1.2.1 Verification in DGS

The basic steps of verification in DGS are as follows:

- Students verify a given statement in several concrete situations, e.g. with a ruler and compass; this is the classical approach.
- DGS enables students to verify a statement in an *infinite* number of situations.
- If a statement is valid by dragging all possible free parameters, then the statement is true with very high probability.

This gives students confidence that the fact is indeed true and what we need is a logical proof. We must realise that verification is *not* a proof since it is based on numerical computation.

Nevertheless, verification in DGS is an important tool even for experts since we can use it to state conjectures. In elementary schools, verification in DGS can replace the exact mathematical proof and help motivate students.

### 3.1.2.2 Automated proving

Automated proving of a statement can be done on computer using CAS. Basic steps of automated proving are as follows <sup>1,3</sup>:

- Introduction of a coordinate system.
- Algebraic formulation of a problem.
- Proof of a statement in an algebraic form.
- Searching for additional conditions, if necessary.

Human intervention is often needed. Most problems that can be proved classically can be proved automatically as well. With a computer we can prove problems that are difficult or even impossible to prove using a classical approach, e.g. to execute non-Euclidean constructions.

The first computer proof was used to solve the *four colours problem*:

#### ***Are four colours enough to colour any planar map?***

On June 21, 1976, Appel, Haken and Koch solved it with three IBM computers in 1,200 hours of computer time – this was the advent of computer proving. It was necessary to overcome psychological barriers; computer proofs cannot be verified by hand.

We frequently hear from students “Are proofs necessary?” Students often think that proofs are useless. They say that it suffices to verify a statement for several cases. As teachers we should show them that such a method can fail. See the next example:

#### ***Ancient Chinese prime number test:***

$$\text{Natural number } n > 2 \text{ is prime} \Leftrightarrow n \mid (2^{n-1} - 1).$$

Let us try to verify it:

$$3 \text{ is prime} \Leftrightarrow 3 \mid (2^{3-1}-1), \text{ true,}$$

$$4 \text{ is not prime} \Leftrightarrow 4 \nmid (2^{4-1}-1), \text{ true,}$$

$$5 \text{ is prime} \Leftrightarrow 5 \mid (2^{5-1}-1), \text{ true,}$$

$$6 \text{ is not prime} \Leftrightarrow 6 \nmid (2^{6-1}-1), \text{ true,}$$

$$7 \text{ is prime} \Leftrightarrow 7 \mid (2^{7-1}-1), \text{ true,}$$

$$8 \text{ is not prime} \Leftrightarrow 8 \nmid (2^{8-1}-1), \text{ true,}$$

$$9 \text{ is not prime} \Leftrightarrow 9 \nmid (2^{9-1}-1), \text{ true,}$$

In spite of this, the statement does not hold!

Namely, for  $n = 341$ , which is a compound number since with  $341 = 11 \cdot 31$ , we get  $341 \mid (2^{340} - 1)$ .

There are other such numbers 561, 645, 1105, 1387, 1729, ... which are called 2-pseudoprimes.

#### Example 1:

*Prove that the three altitudes (or the lines containing the altitudes) of a triangle are concurrent.*

**Verification in DGS:** We must verify that three heights of a triangle are concurrent (Fig. 1).

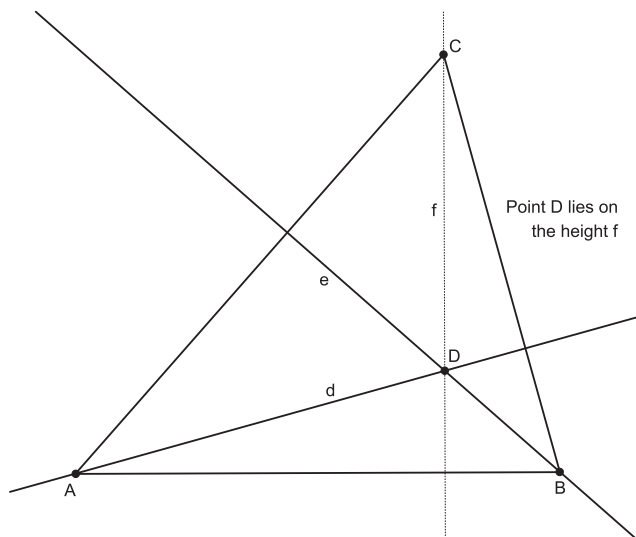

Fig. 1: The intersection  $D$  of the altitudes  $d, e$  lies on  $f$

First we suppose that  $D$  is the intersection of two altitudes –  $d$  and  $e$ . Second we must show that  $D$  belongs to  $f$ .

In GeoGebra we construct two altitudes  $d$  and  $e$  and denote their intersection by  $D$ . Then we construct the third altitude  $f$ . We must verify that  $D$  belongs to  $f$ . Moving interactively with vertex  $C$  it seems that  $D$  belongs to the altitude  $f$ . In the window "Relation between two objects" we click on  $D$  and then on  $f$  and the answer "point D lies on f" appears. It means that for this individual situation the statement is verified. When we move with vertex  $C$  then the answer disappears and we use the window "Relation between two objects" again to verify the statement for another situation. To verify the statement in an infinite number of situations, we use the text "point D lies on f" and write the condition for when the text appears. This condition could be distance  $(D, f) = 0$ . Then, moving with any vertex of a triangle, point  $D$  still lies on altitude  $f$ .

**Automated (computer) proof:** Denote  $A = [0,0]$ ,  $B = [1,0]$ ,  $C = [u,v]$ ,  $D = [p,q]$ , (Fig. 2).

Now we will describe hypotheses and the conclusion in an algebraic form. As

$$\begin{aligned} d &:= (u-1)x + vy = 0, \\ e &:= ux + vy - u = 0, \\ f &:= x - u = 0 \end{aligned}$$

then

$$D \in d \cap e \Leftrightarrow (u-1)p + vq = 0 \wedge up + vq - u = 0.$$

We must show that

$$D \in f \Leftrightarrow p - u = 0$$

This is easy since the algebraic identity

$$p - u = -1 \cdot ((u-1)p + vq) + 1 \cdot (up + vq - u)$$

holds.

We expressed the conclusion polynomial  $p - u$  as a linear combination of polynomials defined in hypotheses

$$(u-1)p + vq, \quad up + vq - u$$

with coefficients  $-1$  and  $1$ . The statement is proved.

In more complex examples the work of finding linear combinations is done by computer.

**Classical proof:** We construct an auxiliary triangle  $A', B', C'$ , where  $A'B' \parallel AB$ ,  $B'C' \parallel BC$ ,  $C'A' \parallel CA$ , (Fig. 3).

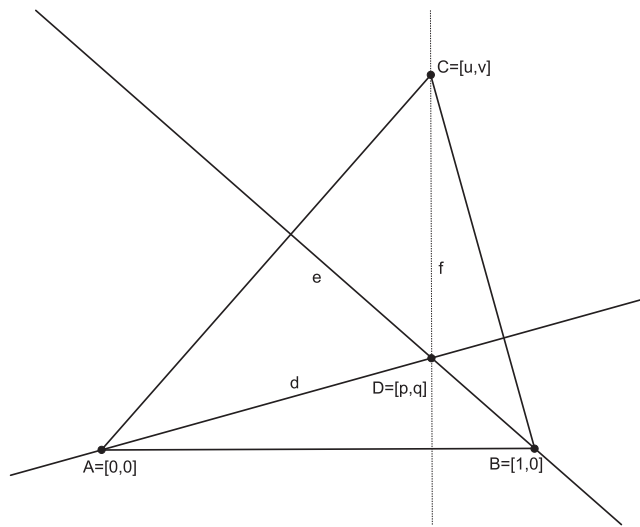

Fig. 2: Three altitudes  $d, e, f$  are concurrent

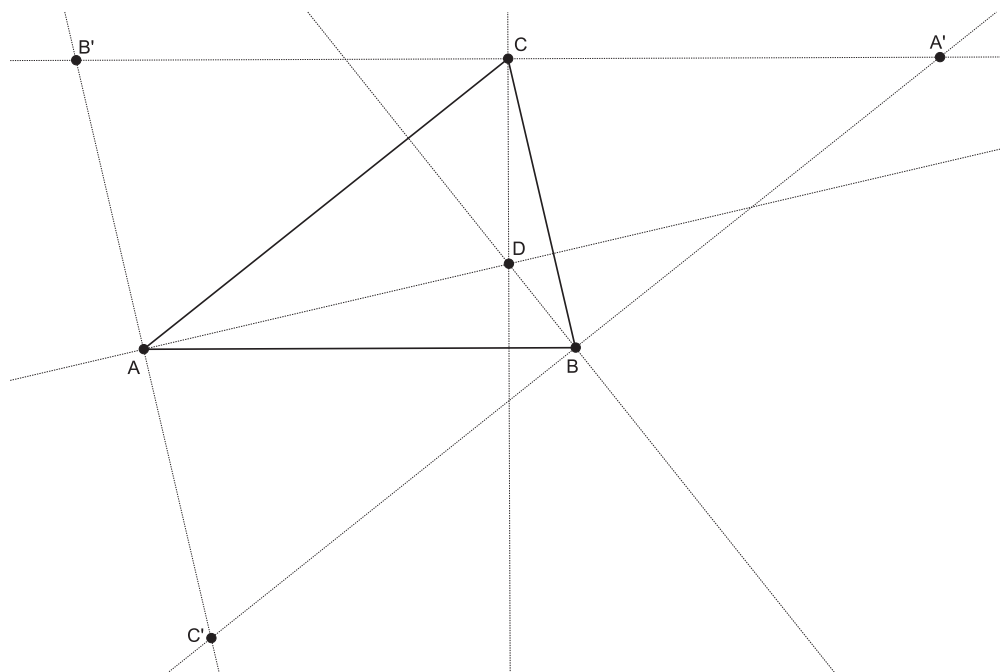

Fig. 3: Classical proof



Then the heights  $d, e, f$  of  $ABC$  are side bisectors of  $A'B'C'$ . Now it is easy to show that three side bisectors of a triangle are concurrent.

In summary, we showed three types of proofs

- Verification in DGS (which is not an exact proof),
- Automated (computer) proof,
- Classical proof.

If we ask students “What type of proof do you prefer?” and “What are the strengths and weaknesses of each proof?”, they usually answer that they prefer verification and classical proof since in these cases they have a real insight into the problem. But to prove a theorem classically you need a key idea. If there is no key idea, you can try an automated proof.

Let us look at another example in the form of a geometric inequality.

**Example 2: Weitzenböck inequality<sup>7</sup>**

Let  $ABC$  be a triangle with side lengths  $a, b, c$ , and area  $P$ . Then

$$a^2 + b^2 + c^2 \geq 4\sqrt{3}P, \quad (1)$$

where equality occurs if  $ABC$  is equilateral.

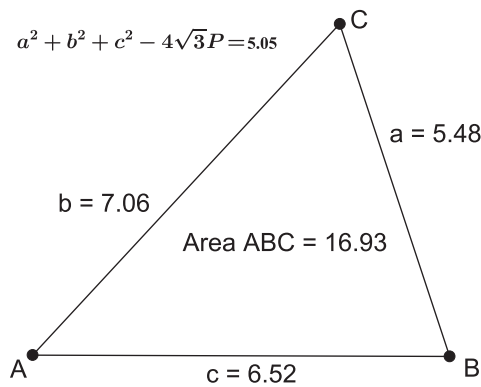

Fig. 4: Verification in DGS of the Weitzenböck inequality

We will show four types of proofs of the inequality (1) – verification in DGS, automated proof, classical proof and visualised proof, which sometimes can be done and seems to be the best method.

**Verification in DGS:** The statement is verified by means of numerical computation of the value of the left side in (1). By dragging the mouse we see that the values are always non-negative (Fig. 4). From this we can suppose that the inequality (1) holds. But be careful, sometimes this method can fail because of numerical computations.

**Automated proof:** We must prove that

$$a^2 + b^2 + c^2 - 4\sqrt{3}P \geq 0.$$

We will describe the geometric situation in a rectangular coordinate system.

Let  $A = [0,0]$ ,  $B = [c,0]$ ,  $C = [u, v]$ , (Fig. 5).

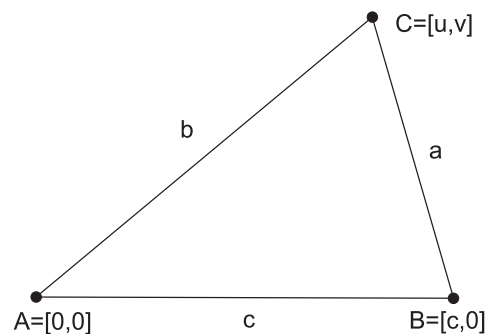

Fig. 5: Automated proof of Weitzenböck inequality

Then

$$a = |BC| \Rightarrow a^2 = (u - c)^2 + v^2,$$

$$b = |CA| \Rightarrow b^2 = u^2 + v^2,$$

$$P = \text{area of } ABC \Rightarrow P = \frac{1}{2} cv.$$

We write the left side in terms of coordinates

$$a^2 + b^2 + c^2 - 4\sqrt{3}P = (u - c)^2 + 2v^2 + u^2 + c^2 - 2\sqrt{3}cv$$

which can be expressed as sum of squares

$$(2) \quad a^2 + b^2 + c^2 - 4\sqrt{3}P = 2\left(u - \frac{c}{2}\right)^2 + 2\left(v - \frac{c\sqrt{3}}{2}\right)^2 \geq 0$$

with equality if  $u = \frac{c}{2}$  and  $v = \frac{c\sqrt{3}}{2}$ , i.e.  $ABC$  is equilateral.

**Note:** Here the decomposition (2) was done by hand. In more complex cases the decomposition can be found by computer.

**Classical proof:** Classical proof of (1) is based on the inequality between arithmetic and geometric mean and Cauchy-Schwartz inequality. First we rearrange (1) with the use of the formula of Heron into

$$a^2 + b^2 + c^2 - 4\sqrt{3}P \geq 3(a + b + c)(-a + b + c)(a - b + c)(a + b - c).$$

Using the inequality between arithmetic and geometric mean we get

$$3(a + b + c)(-a + b + c)(a - b + c)(a + b - c) \leq 3(a + b + c)(a + b + c)^3 / 27$$

or

$$3(a + b + c)(-a + b + c)(a - b + c)(a + b - c) \leq (a + b + c)^4 / 9.$$

Then by Cauchy-Schwarz inequality we conclude the proof

$$(a + b + c)^4 / 9 = ((a + b + c)^2 / 3)^2 \leq (3(a^2 + b^2 + c^2) / 3)^2 = (a^2 + b^2 + c^2)^2.$$

**Visualised proof:** Sometimes we are able to do a visualised proof, which is the best method as we can watch what is happening when we change parameters of an investigated geometric object (Fig. 6). We rearrange the inequality (1) into the form

$$a^2 + b^2 + c^2 \geq 4\sqrt{3}P \Rightarrow \frac{a^2\sqrt{3}}{4} + \frac{b^2\sqrt{3}}{4} + \frac{c^2\sqrt{3}}{4} \geq 3P$$

from which the inequality (1) follows. Realise that for the area  $A$  of an equilateral triangle with the side length  $a$  the formula  $A^2 = a^2\sqrt{3}/4$  holds. The triangle is divided into three differently coloured parts for a better view.

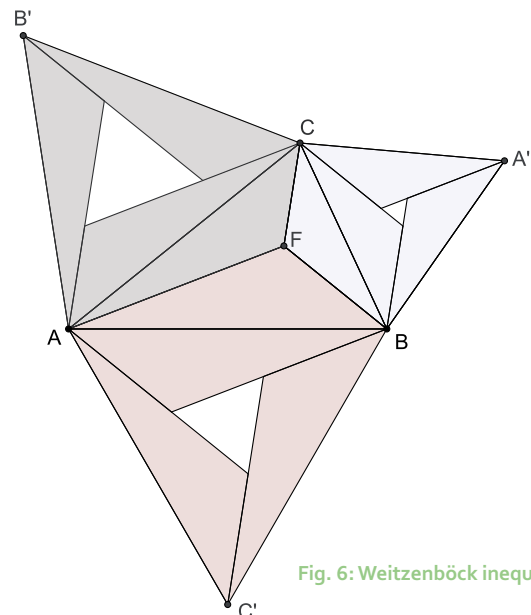

Fig. 6: Weitzenböck inequality

### 3.1.3 Deriving theorems

What is automated derivation of theorems? By automated derivation of theorems we mean finding geometric formulas holding among prescribed geometric magnitudes, which follow from the given assumptions<sup>4</sup>. Derivation is based on the process of elimination of variables<sup>6</sup>.

Searching for loci of points of given properties is a part of derivation. Hundreds of theorems have been found by this method.

#### Example 3:

Given a planar quadrilateral  $ABCD$  with side lengths  $a, b, c, d$  and diagonals  $e, f$ .  
Find a relation that holds among  $a, b, c, d, e, f$ .

Adopt a coordinate system, where  $A = [0,0]$ ,  $B = [a,0]$ ,  $C = [u,v]$ ,  $D = [w,z]$ , (Fig. 7). Then

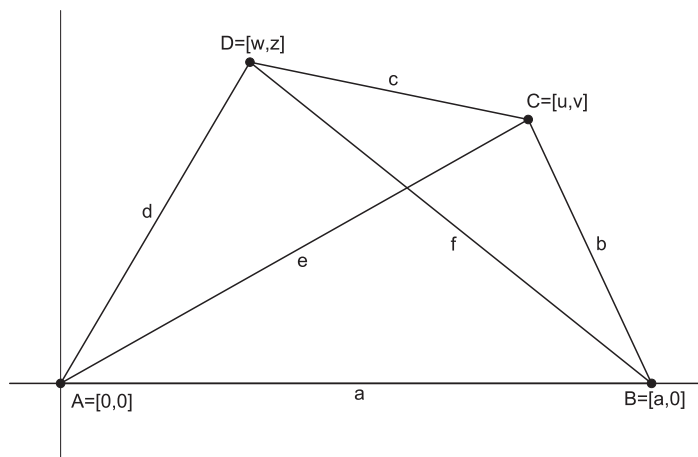

$$\begin{aligned}
 b = |BC| &\Rightarrow h_1 := (u-a)^2 + v^2 - b^2 = 0, \\
 c = |CD| &\Rightarrow h_2 := (w-u)^2 + (z-v)^2 - c^2 = 0, \\
 d = |DA| &\Rightarrow h_3 := w^2 + z^2 - d^2 = 0, \\
 e = |AC| &\Rightarrow h_4 := u^2 + v^2 - e^2 = 0, \\
 f = |BD| &\Rightarrow h_5 := (w-a)^2 + z^2 - f^2 = 0.
 \end{aligned}$$

Fig. 7: Find a relation that holds among  $a, b, c, d, e, f$

In the ideal  $I = (h_1, h_2, \dots, h_6)$  we eliminate variables  $u, v, w, z$ . In the freely distributed program CoCoA<sup>8</sup> we write

```

Use R ::= Q[a,b,c,d,e,f,u,v,w,z];
I := Ideal((u-a)^2+v^2-b^2, (w-u)^2+(z-v)^2-c^2, w^2+z^2-d^2, u^2+v^2-e^2,
(w-a)^2+z^2-f^2);
Elim(u..z, I);

```

and get the result

$$-a^4c^2 + a^2b^2c^2 - a^2c^4 + a^2b^2d^2 - b^4d^2 + a^2c^2d^2 + b^2c^2d^2 - b^2d^4 - a^2b^2e^2 + a^2c^2e^2 + b^2d^2e^2 - c^2d^2e^2 + a^2c^2f^2 - b^2c^2f^2 - a^2d^2f^2 + b^2d^2f^2 + a^2e^2f^2 + b^2e^2f^2 + c^2e^2f^2 + d^2e^2f^2 - e^4f^2 - e^2f^4 = 0$$

which is the desired relation.

### 3.1.4 Locus equations

In this part we will search for loci of points of given properties. This topic belongs to difficult parts of geometry curricula at all school levels. New tools and technologies greatly facilitate the handling of this problem. Exploring loci we use both DGS and CAS. This is a valuable topic for students.

Searching for loci with students at the University of South Bohemia we keep the rules:

- First *demonstrate* the problem with DGS and construct some points of the searched locus.
- Try to *guess* the locus based on the previous step.
- Then use the icon Locus (Geogebra, Cabri,...) to *verify* the locus. Remember that this is not exact!
- Using CAS (Derive, CoCoA, Epsilon, Maple, Mathematica,...) *derive* the locus equation exactly.

#### Example 4:

Let  $ABC$  be a triangle with the given base  $AB$  and the vertex  $C$  on a line  $k$ . Find the locus of the orthocentre  $G$  of  $ABC$  when  $C$  moves along the line  $k$ .

When  $C$  moves on  $k$  then  $G$  moves along a curve like in Fig. 8.

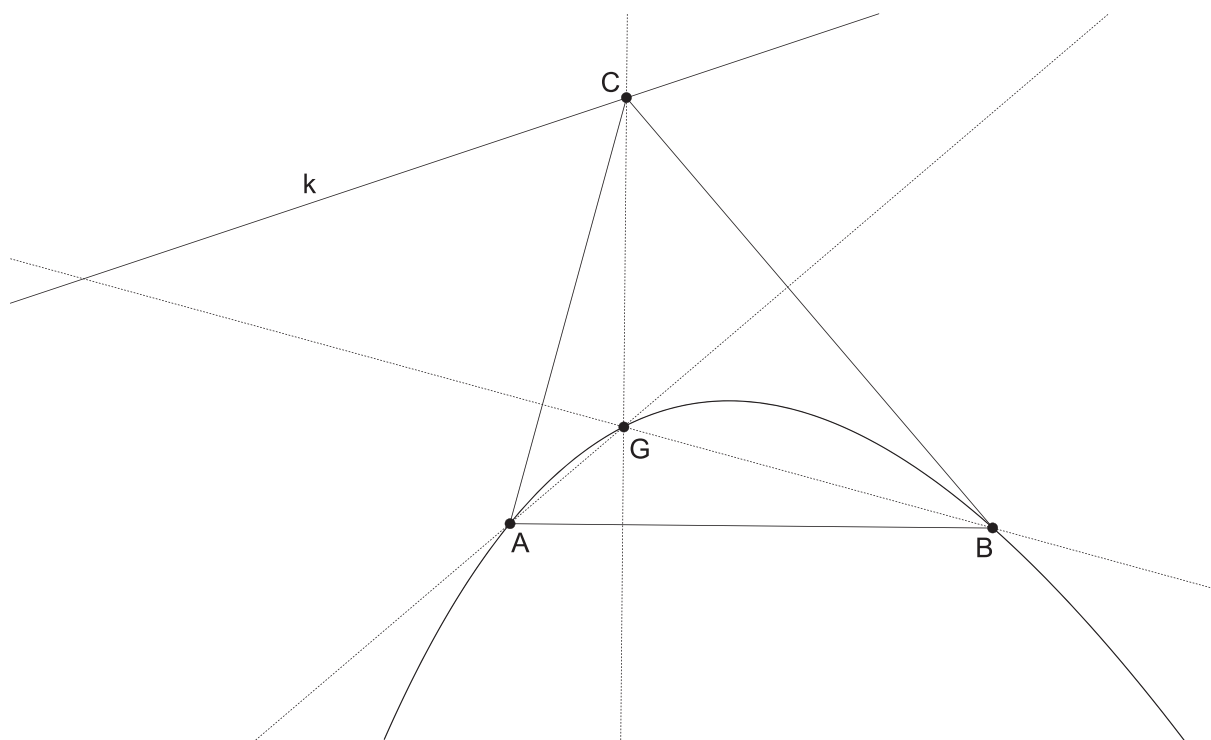

Fig. 8: The locus is similar to a parabola

First students say that the curve is a *parabola* (Fig. 8). Second some students say after dragging the line  $k$  that the curve is a *hyperbola* (Fig. 9). When I ask them for the reason *why* it is a parabola or hyperbola, they do not know. A question arises – what is the solution?

To find it, we derive the locus equation:

Place a coordinate system so that  $A = [0,0]$ ,  $B = [1,0]$ ,  $C = [u,v]$ ,  $G = [p,q]$ , and let  $k$  be an arbitrary line with the equation  $k : ax + by + c = 0$ .

We translate the geometry situation into the set of polynomial equations.

For the intersection  $G = [p,q]$  of the altitudes  $h_{AB}$  and  $h_{BC}$  it holds:

$$G \in h_{AB} \Rightarrow h_1 : p - u = 0,$$

$$G \in h_{BC} \Rightarrow h_2 : (u - 1)p + vq = 0.$$

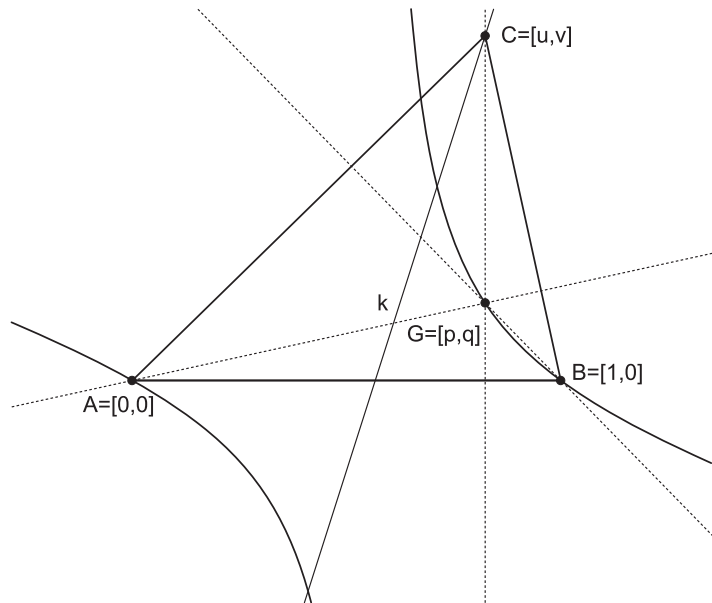

Fig. 9: The locus is similar to a hyperbola

Further

$$C \in k \Rightarrow h_3 : au + bv + c = 0.$$

We get the system of three equations  $h_1 = 0$ ,  $h_2 = 0$ ,  $h_3 = 0$  in variables  $u, v, p, q, a, b, c$ . To find the locus of  $G = [p,q]$  we eliminate variables  $u, v$  in the ideal  $I = (h_1, h_2, h_3)$  and get a relation in  $p, q$  which depends on  $a, b, c$ . We enter

```
Use R := Q[a, b, c, u, v, p, q];
I := Ideal (au+bv+c, p-u, (u-1)p+vq);
Elim(u..v, I);
```

and get the equation

$$C(p, q) := bp^2 - apq - bp - cq = 0$$

in variables  $p, q$ . We can suppose that  $(a, b) \neq (0, 0)$  since in this case the line  $k$  is not defined. Then  $C(p, q) = 0$  is the equation of a conic.

The cases  $k = h_{AB}$ ,  $k = AC$  and  $k = BC$  lead to singular conics that consist of two intersecting lines (they are not depicted).

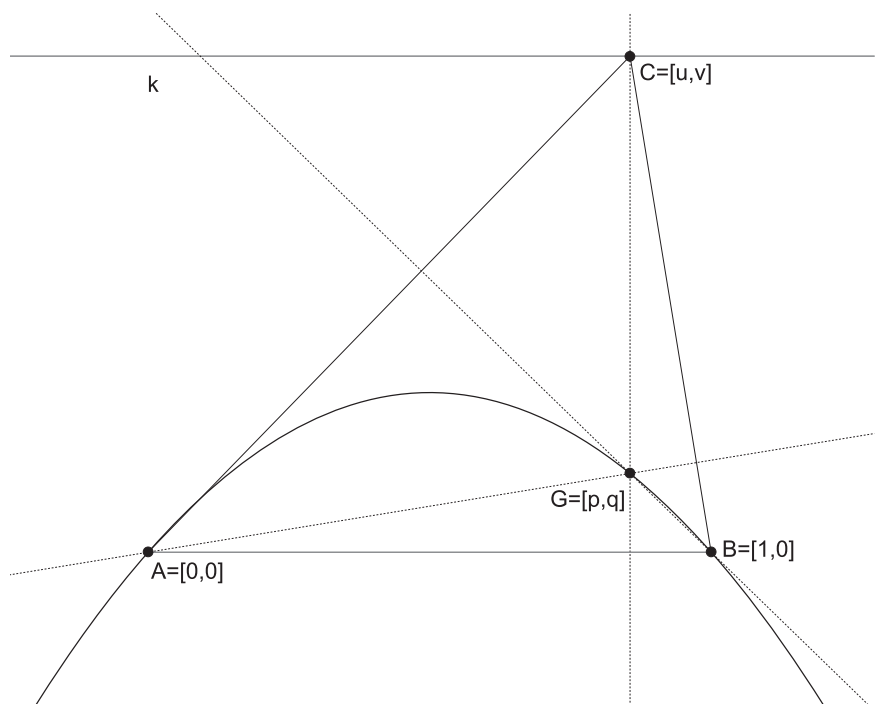

Fig. 10: If  $k$  is parallel to  $AB$ , the locus is a parabola

Considering regular conics we get *two* cases:

1. If  $k$  is parallel to  $AB$ , the locus is a parabola with the vertex  $[\frac{1}{2}, \frac{b}{4c}]$  and a parameter  $|\frac{c}{2b}|$ , (Fig. 10).
2. If  $k$  is not parallel to  $AB$ , we obtain a hyperbola centred at  $[-c/a, -b(a+2c)/a^2]$  with one asymptote going through the intersection of  $AB$  and the line  $k$ , which is perpendicular to  $AB$ , and the second asymptote perpendicular to the line  $k$  (Fig. 11).

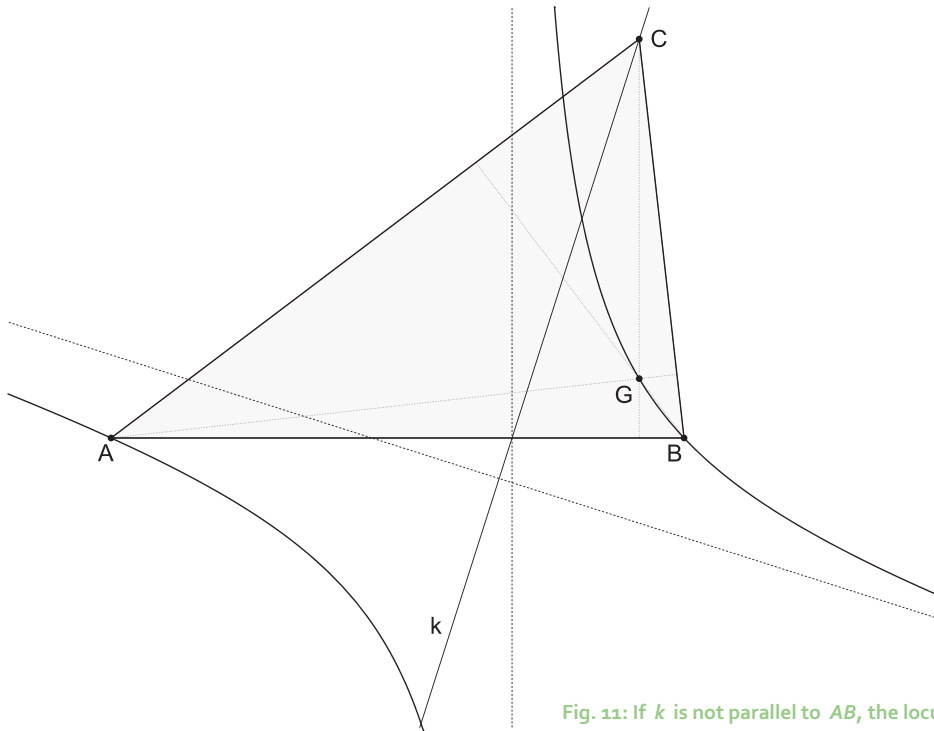

Fig. 11: If  $k$  is not parallel to  $AB$ , the locus is a hyperbola

**Note:**

- The loci above were found using algebraic and computer tools.
- In this simple example the loci can be found by hand as well.
- What is missing? A classical geometric proof!

The next example shows an algebraic curve of the higher degree as a locus.

**Example 5:**

Let  $ABC$  be a triangle with the given side  $AB$  and the vertex  $C$  on a circle  $k$  centered at  $A$  and radius  $|AB|$ . Find the locus of the orthocentre  $G$  of  $ABC$  when  $C$  moves along  $k$ .

First we construct in DGS a triangle  $ABC$  with a point  $C$  on the circle  $k$ . Using the window "Locus" we construct the locus of the orthocentre  $G$  when  $C$  moves along  $k$ .

Derivation of the locus equation is as follows:

Suppose that  $A = [0,0]$ ,  $B = [a,0]$ ,  $C = [u,v]$  and  $G = [p,q]$ , (Fig. 12).

Then

$$G \in h_{AB} \Rightarrow h_1 : p - u = 0,$$

$$G \in h_{BC} \Rightarrow h_2 : (u - a)p + vq = 0,$$

$$G \in k \Rightarrow h_3 : u^2 + v^2 - a^2 = 0.$$

Elimination of  $u, v$  in the system  $h_1 = 0, h_2 = 0, h_3 = 0$  gives in the freely distributed program Epsilon <sup>9</sup>

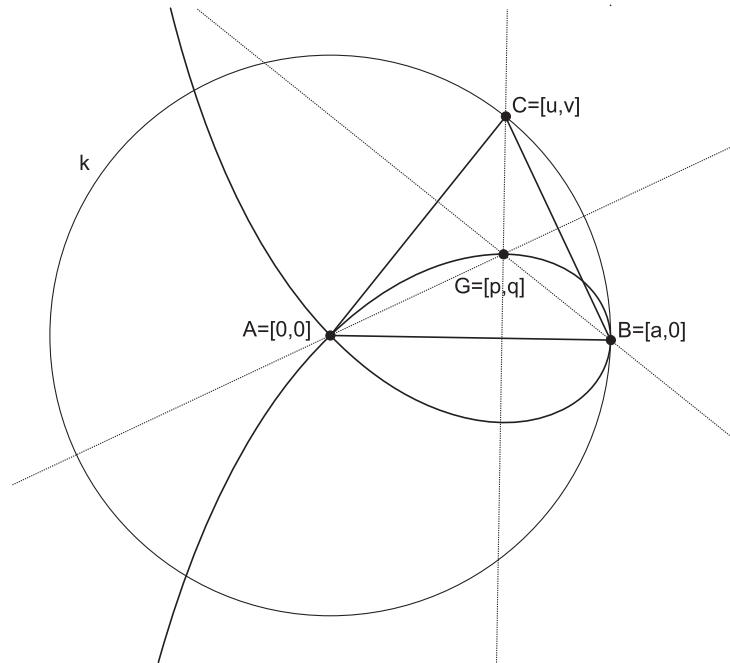

Fig. 12: The locus of  $G$  when  $C$  moves along  $k$  is a strophoid

```
with(epsilon) ;
U := [p-u, (u-a)*p+v*q, u^2+v^2-a^2] :
X := [p, q, u, v] :
CharSet(U, X) ;
```

a polynomial which leads to

$$p^2(p - a) + q^2(p + a) = 0$$

which is the equation of a cubic curve called strophoid <sup>2, 5</sup>. The equation of a strophoid can also be written in the form of two functions

$$q = \pm p \sqrt{\frac{a-p}{a+p}}.$$

This form enables us to investigate properties of a strophoid with the methods of calculus used in secondary schools.

The strophoid, or more exactly the right strophoid, has many interesting properties. See the next example.

**Example 6:**

Let  $A$  and  $B$  be fixed points and let  $S$  be a point on a perpendicular  $s$  to  $AB$  at  $A$ . Determine the locus of the intersections  $G$  of the circle  $k$  centered at  $S$  with radius  $|SA|$  and the line  $BS$  when  $S$  moves along the line  $s$ .

We derive the locus by eliminating suitable variables in a coordinate system (Fig. 13).

Place a coordinate system so that  $A = [0,0]$ ,  $B = [a,0]$ ,  $S = [0,s]$  and  $G = [p,q]$ . For the intersection  $G = [p,q]$  of the line  $BS$  and a circle  $k$  we get

$$G \in BS \Rightarrow h_1 : sp + aq - as = 0,$$

$$G \in k \Rightarrow h_2 : p^2 + (q-s)^2 - s^2 = 0.$$

Elimination of  $S$  in the system  $h_1 = 0$ ,  $h_2 = 0$  gives the locus equation of the point  $G$ . In Epsilon we enter

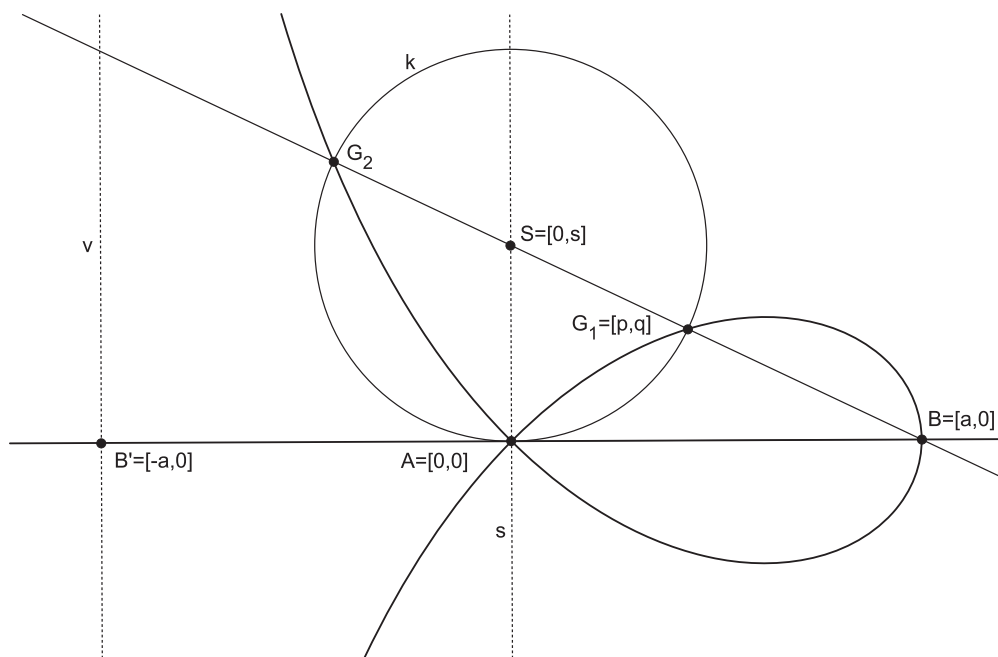

Fig. 13: The locus of  $G$  when  $S$  moves along the line  $s$  is a strophoid

```
with(epsilon);
U:= [s*p+a*q-a*s, p^2+(q-s)^2-s^2]:
X:= [p, q, a, s]:
CharSet(U, X);
```

We get the same locus as in the previous case.



### 3.1.5 Conclusions

The use of new mathematical software like dynamic geometry systems and computer algebra systems has dramatically changed the way we teach mathematics. Using DGS students visualise problems, and by interactively changing parameters they formulate conjectures and verify them. With CAS they can even prove theorems and discover new formulas. Computers extend the horizon of knowledge at school. For example, in the past we studied lines and conics at school. In the future students will study curves of higher order. The examples presented here show just how important computers are in IBME.

## 3.2 IBME and ICT – the experience in Bulgaria

*Petar Kenderov, Evgenia Sendova, Toni Chehlarova*

### 3.2.1 Digital learning environments in support of the IBME

The potential of the digital learning environments for supporting a relationship among teachers and students as members of a research team in which the teacher acts as a discovery-guide has been identified as crucial by the members of the Bulgarian Fibonacci team <sup>10, 11</sup>. The participants in the inquiry-based learning process are expected to observe a specific phenomenon, to formulate a conjecture based on these observations, to check and verify this conjecture experimentally. Such a style enables the students (and their teachers alike) to experience the flavor of the real mathematics as a field of new discoveries. Even if they happen to re-discover America, they would enjoy the process of sailing to it, and would enhance their creative thinking <sup>12</sup>. They would learn to try and compare various strategies for attacking a problem and would understand that in mathematics the road to a goal is often more important than the goal itself. Which method to choose, how to apply it, which parts to neglect are aspects not covered by any method, thus mathematics should be experienced not just as a science but as art as well!

The explorations in a dynamic digital environment allow the students to decide what is invariant or crucial in a specific construction, what could be neglected, rejected or modified. Furthermore, they could formulate their own problems by implementing similar ideas in a context of their own interest. Last but not least, they could become co-authors of the toolkit of a specific dynamic computer environment by enriching it with tools constructed by themselves.

While developing the dynamic resources in support of the IBME, the Bulgarian Fibonacci team tried to interweave all these ideas – a challenging task in view of the relatively conservative mathematics curriculum and methods of evaluation. But the task was worth attacking since based on previous experience (see also section 4.5.1) we knew that the learning process could be made enjoyable and natural for the students if they were provided with appropriate dynamic environments functioning as mathematical laboratories.

Let us formulate in a nut shell the basic principles behind the development of resources published as dynamic scenarios on the Bulgarian Fibonacci site <sup>13</sup>. These resources have been carefully designed to provide opportunities for

- the teachers to work as research partners of their students;
- the students to find their own learning paths according to their interests and potential;
- all users to build the knowledge in a cross-disciplinary context (especially integrating mathematics with ICT, natural science and art).

### 3.2.2 Basic types of dynamic learning environments

Various types of environments and models have been used for the development of these resources. Below we consider three basic types with representative examples from the resources in <sup>13</sup>:

- Ready-made computer applications
- Modifiable applications
- Programming-based exploratory environments

#### 3.2.2.1 Ready-made computer applications

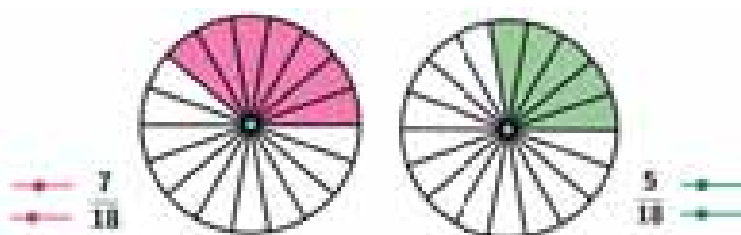

Fig. 14: Comparing fractions with equal denominators

In a model for comparing common fractions <sup>14</sup> the students can vary the numerator and the denominator of each of the two fractions by means of sliders (Fig. 14) as well as to move the figures depicting them. Thus, if necessary the figures could be imposed one over the other letting the students figure out the rule for comparing two fractions with equal denominators.

This application is also suitable for organizing the explorations in search of rational methods for comparing (ordering) fractions of the kind

$$\frac{3}{4}; \frac{4}{5}; \frac{5}{6}; \frac{6}{7}; \frac{7}{8}; \frac{99}{100}; \frac{200}{201}$$

The ready-made learning environments are very suitable not only for younger students. For instance, a dynamic trigonometer (Fig. 15) is used in the upper secondary school for the students to observe phenomena and relations due to the change of the angle.

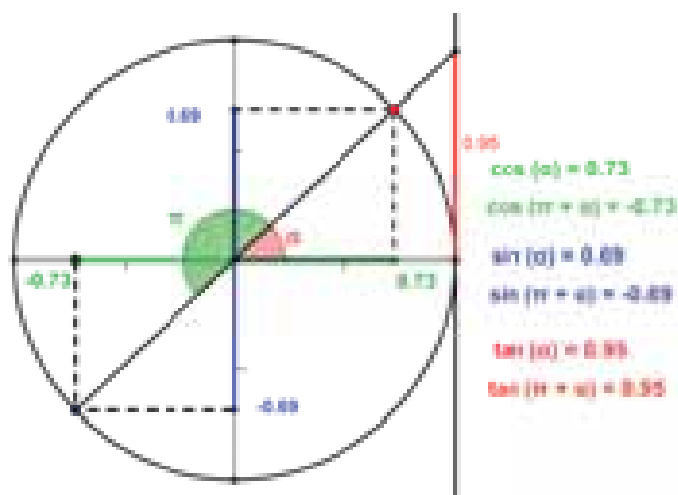

Fig. 15: Comparing fractions with equal denominators

#### 3.2.2.2 Modifiable applications

The option of modifying a specific computer application so as to solve a class of similar problems is another important feature of the learning environments we take into consideration.

In addition, the modification could concern the content of the available tools.

If the students are not very familiar with the environment (GeoGebra in this case) they might be distracted by the variety of available tools. To avoid this problem we would leave just the buttons needed for solving a specific

set of problems. The option for hiding part of the buttons is particularly appropriate when working on the topic *Elementary and Basic Constructions in Geometry*<sup>15</sup>.

We leave a subset of the original toolbar, viz. all the buttons necessary for the ruler-and-compass elementary constructions simulating the work with an idealised ruler, i.e. one assumed to be infinite in length and with no markings on it (Fig. 16).



Fig. 16: A subset of the original toolbar

After solving some basic construction problems the students create all the buttons corresponding to the ruler-and-compass elementary constructions. Thus they feel as co-authors of the toolbar offered originally by the developers of the environment.

Such an approach is a very important aspect of the *constructionism* – an educational philosophy in which the students become constructors of their own knowledge and make their products a public entity<sup>16</sup>.

Another type of the modifiable learning environments are the so-called *half-baked* computer applications<sup>17</sup>.

An example from our resources is the setting for the construction of a triangle by two sides and the angle between them (SAS) – the half-baked environment comprises the construction of two segments with a common point and an angle formed by two rays (Fig. 17).

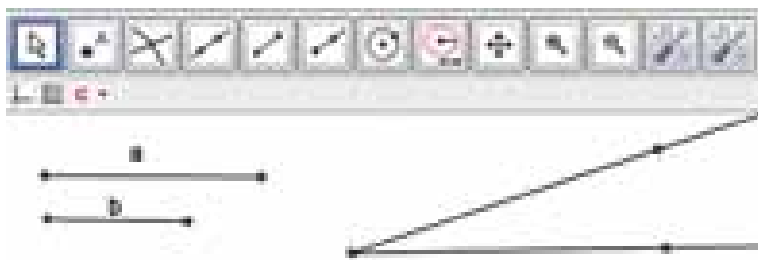

Fig. 17: A half-baked environment for the SAS construction

In the cases of more complex problems (including reality-based ones) it is a good idea to create dynamic models at different levels. Let us consider for example

... the problem of folding a rectangular napkin so that:

- the monogram is placed on a side of the rectangle not containing it,
- the piece being folded is entirely on the remaining part and has a minimal area.

Two dynamic models (Fig. 18) are proposed in <sup>18</sup>.

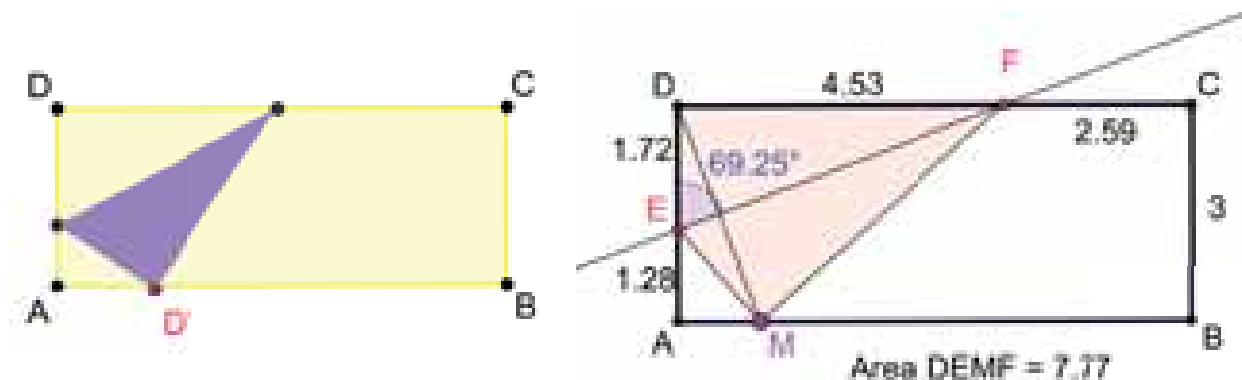

Fig. 18: Dynamic models for the “Folding a rectangular napkin” problem

The students can explore rectangles of various size, and re-formulate the problem as a problem to be proven (even without knowing calculus).

Talking about modification, let us note at this point that a new, crucial aspect of the inquiry based mathematics education is the re-formulation of the problems. The standard phrase “Prove that...” in the classical formulation of problems is often replaced by “Find a relationship/pattern...”, “Determine the type of...”, “Formulate as many conjectures as you can about...”

We present in the table below the classical formulations of some well known geometric problems together with new formulations in exploratory style <sup>19</sup>:

The classical formulation	An exploration-enhancing formulation
<i>The segments AC and BD are diameters of a circle.</i>	
<b>Prove that ABCD is a rectangle.</b>	<b>What is the type of the quadrilateral ABCD?</b>
<i>The diagonals AC and BD of a square meet at a point O. The points M and N are midpoints of the segments DO and BO.</i>	
<b>Prove that AMCN is a square.</b>	<b>What properties of the quadrilateral AMCN have you noticed?</b>
<i>Let CL be the angular bisector of the right angle of the triangle ABC, and M and N be the feet of the perpendiculars from the point L to the legs.</i>	
<b>Prove that LMCN is a square.</b>	<b>What can you say about the quadrilateral LMCN?</b>
<i>Two perpendicular lines are passing through the centre of a square.</i>	
<b>Prove that the quadrilateral with vertices the intersection points of the two lines with the sides of the square is also a square.</b>	<b>Determine the type of the quadrilateral with vertices the intersection points of the two lines with the sides of the square.</b>
<i>CM is a median of <math>\triangle ABC</math>. The segment <math>MN = MC</math> is on the median’s extension.</i>	
<b>Prove that ANCB is a parallelogram.</b>	<b>What is the type of the quadrilateral ANCB if:</b> a) $\triangle ABC$ is arbitrary; b) $\angle C = 90^\circ$ ; c) $AC = BC$ ; d) $\triangle ABC$ equilateral? <b>When is ANCB a square?</b>

Based on their own explorations the students first formulate conjectures which afterwards they are motivated to prove.

Modifying (in the sense of editing) a specific file (procedure, protocol) according to a given goal is another crucial element of the teacher preparation. Such skills should become natural not only for the teachers but also for their students and the preparation of an appropriate ground is based on creative integration of knowledge from various fields. The process of editing is specific for each digital environment, but in every single one we could talk about its *axioms and language*, and the editing could be considered as a specific mathematics application. While “clicking and dragging” could also be considered as a specific kind of a language, having the procedure of the user’s mathematics activities described in the form of a sequence of text commands is very convenient for debugging, editing and modifying. Out of all possible methods for creating educational software, to use a programming language is perhaps the richest one in terms of functionality<sup>20</sup>.

### 3.2.2.3 Programming-based exploratory environments

A notable example for this is *Geomland*<sup>21, 22</sup>. Initially it has been developed as a standalone Logo implementation with a focus on plane geometry. The *Geomland* language contains tools for working with geometric objects such as points, segments, lines, circles, vectors and sets of such objects. Each object is characterized by a name, a value, an image, and its relationships to other objects. (The experience with this environment is considered in more details in section 4.5.1).

The new version of *Geomland* has been re-implemented as a library in *Elica*<sup>23</sup>. *Geomland* is used as a core development language for the scenario *Reflecting on the reflection*<sup>24</sup>, based on<sup>25</sup>. It describes a programmable and constructive approach for explorations of the geometric transformation reflection starting with the simplest case (a reflection of a point with respect to a line) and modifying the corresponding procedure consecutively to the most general one (reflection of a set of objects with respect to a point or a line). The end is a virtual simulation of a game based on reflections.

#### *Reflecting on the reflection* – a fragment of the scenario

After warming up with the basic instructions of the *Geomland* language the first task on reflection is to *teach the computer to reflect*.

##### Task:

Construct the reflection  $P_1$  of a given point  $P$  with respect to a given line  $L$ .

The commands are close to the geometrical constructions described in a natural language and preceded below by semicolons:

```
object "L1 line :P 90+heading :L
;construct an object which is a line
;L1 through point P and
;perpendicular to L
object "O isec :L :L1
;construct an object which is the
;intersecting point (O) of the
;two lines
object "R ray :P :O
object "P1 pointon :R 2*distance :P :O
;construct an object P1 which is a point on the ray R from P to O
;at a distance twice the distance from P to O.
```

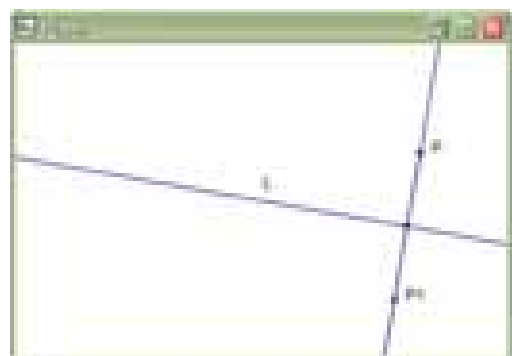

Fig. 19: A reflection of a point with respect to a line

To *teach* the computer to find the reflection point of any point with respect to any line is done by means of the following procedure (the command *ob* is short for *object*):

```
to reflect_p1 :P :L
  local "L1 "O "R
  ob "L1 line :P 90+heading :L
  ob "O isec :L :L1
  ob "R ray :P :O
  output pointon :R 2*distance :P :O
end
```

The further tasks deal with defining procedures for reflecting a segment, a circle, a ray with respect to a given line L, which could be then integrated in the following one-line procedure:

```
to reflect_l :O :L
  output run sentence (word "reflect_first :O.type "l) [:O :L]
end
```

Thus, if the type of the first input of the `reflect_l` procedure (the object **O**) is *point*, the command to be executed will be

```
reflect_p1 :O :L
```

Finally the students are given the task to generalise their procedures so that the first input could be a set of any number of points, lines, rays, segments and circles, and the second input could be a point or a line. Now the following task becomes easy to attack:

**Task:**

Create a picture of the kind shown below (Fig. 20) and its reflection with respect to a point. Have you ever seen such type of reflection? Do you know any physical phenomenons based on it? And any biological?

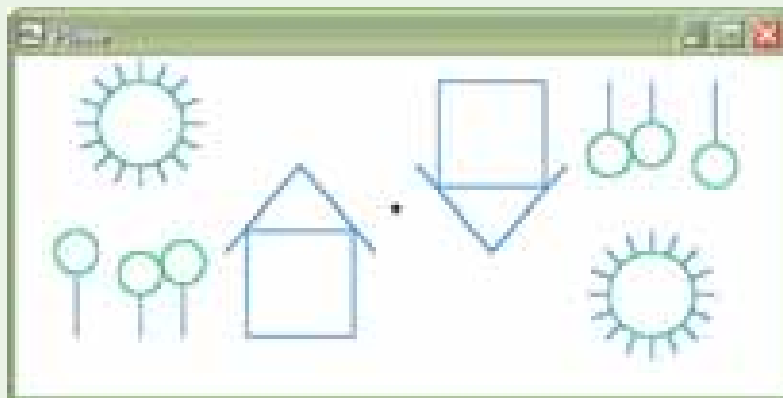
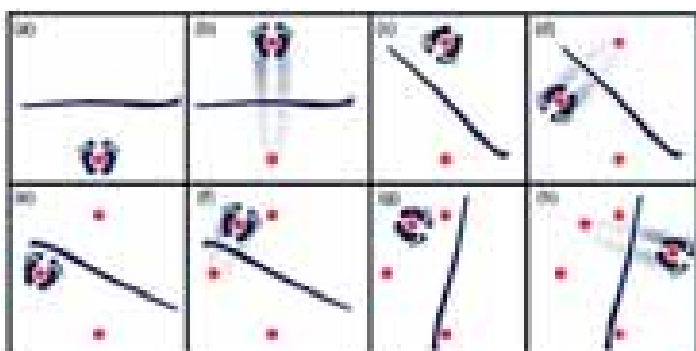

Fig. 20

**Hint:** Search for more information about the lens and the human eye.

The scenario ends with the simulation of a children's game and its implementation in Geomland as described below (Fig. 21).



The player stands in front of a stick (a). Then jumps over it landing in exactly the symmetrical point – on the other side of the stick (b). Then the stick is rotated on an arbitrary angle but around its center (c). After this the player jumps again (d), the stick is again turned (e), the player jumps (f), the stick is turned (g), the player jumps (h) and so on.

Fig. 21a: The Jump-over-the-stick game



```
run *reflect
ob *Angle 0
ob *Player point 100 0 (historical)
ob *Stick line point 0 0 ,Angle
ob *Player reflect :Player :Stick
repeat 50 [ ob *Angle random 100 ]
ob *Positions :history-Player
```

Fig. 21b: A history of 50 player's positions

Let us note that defining new geometric notions and then generalizing them is done by means of a language close to the traditional plane geometry language. An essential property of the objects of *Geomland* is that the learner is armed with the opportunity to move among different definitions of the same notion based either on different geometric constructions or on different language descriptions of the same geometric construction. The necessity of giving precise definitions becomes vital since their validity can easily be checked when they are executed.

Since the mathematical activity is preserved as a procedure of instructions the teachers and learners alike can compare different strategies and solutions, and cultivate an awareness that their work can be developed, modified, improved.

Historically direct manipulations interfaces and interactive programming environments have often been viewed as antipodal. New developments are breaking down the antithesis between programmability and direct manipulations, and point towards new systems which exploit the strength of both <sup>26</sup>.

Here is an example of how programming could be harnessed in the context of *GeoGebra* for constructing various configurations of *Russian dolls* and photo-pictures by means of the *Sequence* command (Fig. 22).



Fig. 22: Getting interesting effects by means of programming in *GeoGebra*

### 3.2.3 Discussion

The resources developed by the *Fibonacci* team are being evaluated by the teachers by testing them in a class setting. The feedback of the teachers is then reflected by the authors thus making the resources “dynamic” in multiple aspects. Furthermore, the teachers modify the team resources or create themselves modules fitting their current pedagogical tasks. After evaluating teachers’ developments we publish them on the project site under the heading *Learning Environments Contributed by Teachers*.

Let us emphasise, that the development of resources making use of dynamic constructions is just an element of the IBME. The discoveries, the representations and the implementation of mathematical objects and ideas could be related to the enhancement of the creative potential of learners by providing appropriate overall conditions and our on-going efforts are in this direction.

We are optimists that the assessment and evaluation mechanisms will reach the level of recognising the achievements of learners who are *able to approach learning as a task of discovering rather than “learning about”, the reward being the discovery itself*<sup>27</sup>. Till then we, in our role of teachers’ educators, have to do our best to be that type of learners ourselves.

### 3.2.4 At the end – some questions for reflection

- How to select and combine various environments in support of the IBME – manipulatives, text resources and digital learning environments?
- How fixed the compulsory curriculum should be now that thanks to the dynamic computer environments various new topics could be introduced revealing the real nature of mathematics as a science?
- Should the dynamic constructions be accompanied with texts (if yes, what kind of texts)?
- Should we develop dynamic environments supplementary to the current textbooks or independent digital textbooks instead?
- How to carry into effect a change in the evaluation system so that it could take into account the level of the acquirement of skills for doing research, for problem solving, for problem posing, for applying mathematics knowledge in real-life situations?
- How to stimulate teachers to organise and maintain the out-of-class work?
- How best to use the modern ICT for the formation and maintenance of communities sharing problems and achievements in the field of mathematics education?

And it might be worth reminding that the most knotty questions should be answered before being asked ...

## 3.3 Interactive geometry for the web and mobile devices

*Matthias Ehmann, Michael Gerhäuser,  
Carsten Miller, Heiko Vogel, Alfred Wassermann*

### 3.3.1 Introduction

Using computer technology in mathematics education has been a very active research area at least since the availability of the personal computer in the 1980’s, see e.g. <sup>34, 35</sup>.



Arguably, for many years one of the biggest obstacles for the integration of computer technology in mathematics education has been the necessity of a computer laboratory. Usually, the class has to stay the whole lesson in the laboratory and not in classroom. But most computer laboratories are filled with big computer screens, the tables are covered by the keyboards. Regular paper-and-pencil work is limited in such an environment. This may have been one of the reasons why many teachers restricted the use of computer technology to presentations of dynamic content in front of the class.

With the presentation of the Apple iPhone in 2007 and the Apple iPad in 2010, followed by a plethora of mobile devices with constantly dropping prices, the situation changed entirely. This new generation of mobile devices is well suited for the classroom. Envisioned already 40 years ago by Alan Kay, one of the pioneers for proposing computers in education <sup>36</sup>, with an astonishing precision, tablets are now available for everyone. In contrast to usage of desktop computers in a computer laboratory, working with tablets blends well with paper-and-pencil work. There is no need anymore to leave the classroom in order to use a computer.

“Because mobile technology ... [are] is becoming more and more relevant for mathematics education” <sup>29</sup>. This movement is amplified by the efforts of several countries to replace printed textbooks by electronic ones. Among the countries which plan to switch to electronic material are Slovenia, South Korea, and the United States <sup>37</sup>. As a consequence for the future, educational software will have to blend well with electronic textbooks.

But the availability of these handheld devices provokes new challenges for interactive mathematics visualisation software <sup>40</sup>. Today’s dynamic mathematics software is expected to be usable on desktop computers as well as on mobile devices. Software developers therefore have not much choice but to use a platform independent design. At the time of writing the only software standard which is able to run on desktop computers and simultaneously on the vast variety of mobile platforms is the HTML5 quasi-standard. This is the common denominator for software which is available on Android, iOS and desktop systems (Windows, Mac OS X and Linux).

An advantage of using HTML5 is that e-books are based essentially on the same technology. For example, the e-book file format standard epub3 <sup>40</sup> is based on large parts of HTML5. Many HTML5 applications can therefore be included in e-books and enable a previously unknown interactive reading experience. That means the borderline between software and e-book does not any longer exist.

### 3.3.1.1 Natural user interface

In the very early days of the computer usage in school it was common to use the command line interface (CLI) to interact with the computer. Examples are computer algebra systems and programming languages like LOGO. To be able to use the software, the user had to know the commands to control the software.

Then, for many years the interaction happened with a graphical user interface (GUI). Now, the students used menus and buttons to control the software. The commands no longer had to be memorised.

The new generation of mobile devices is controlled by finger moves or with a stylus. Gradually we are shifting into the age of natural user interfaces.

“Natural user interfaces (NUIs) are the third generation of user interfaces for computers, after command line interfaces and graphical user interfaces. A NUI uses natural elements or natural interactions (such as voice or gestures) to control a computer program. Being natural means that the user interface is built upon something that most people are already familiar with. Thus, the learning curve can be significantly shortened. This ease of use allows computer scientists to build more complicated but richer user interfaces that simulate the existing ways people interact with the real world.” See <sup>41, 43</sup>, but also <sup>38</sup> for a controversial point of view.

Being forced to develop new software for mobile devices can be taken as chance to rethink the way of interaction and start to go in the direction of a natural user interface. With the project sketchometry we present our first humble experiences with NUI.

### 3.3.1.2 Outline

This section gives an overview of three software projects developed by the authors. JSXGraph <sup>45</sup>, JessieCode <sup>50</sup> and sketchometry <sup>51</sup> are all based on HTML5 technology and therefore can be used on practically all mobile computers as well as on desktop computers.

Sketchometry is a dynamic geometry system (DGS) aimed to be used by the students in classroom. It has a radically new interface which is the first step toward a natural user interface.

JSXGraph is a software library for dynamic mathematics. Its user group consists of software developers, developers of mathematics visualisations and authors of e-books.

While JSXGraph offers the full power and flexibility of a software library, the third project, JessieCode, is a middle layer. It allows to use a mathematically oriented language to create constructions. Additionally, it provides the necessary security measures to be used as a communication language for mathematics in public web forums or wikis.

### 3.3.2 JSXGraph

JSXGraph <sup>31, 32</sup> is a cross-browser library completely written in JavaScript, which enables function plotting, data visualisation and interactive geometry on a web page. First presented in 2008 <sup>30</sup>, it is now included in more and more projects <sup>46</sup>.

JSXGraph provides a mighty and extensive application programming interface (API) consisting of several hundred classes and methods <sup>47</sup>.

#### 3.3.2.1 A small inside into the practical use of JSXGraph in a web page

To implement JSXGraph in the web page you usually start with a <div> element, which should contain declarations for width and height.

```
| <div id='box' class='jxgbox' style='width:600px;height:600px;'></div>
```

The JSXGraph code is linked to this element by using its *id*, i.e. in our example the *id* 'box'. With the property *boundingBox*: $[x_1, y_1, x_2, y_2]$  it is possible to specify a coordinate system. The upper left corner of the box will have coordinates  $(x_1, y_1)$ , the lower right corner will have coordinates  $(x_2, y_2)$ .

```
| <script type='text/javascript'>
|   var board = JXG.JSXGraph.initBoard('box', {boundingbox:[-1.5, 2, 1.5, -1]});
| </script>
```

There is no restriction to the number of JSXGraph boards in a web page. After initialising the JavaScript object board it is ready for the construction of geometric elements. The generic call to create a new geometric object has the following form:

```
| board.create('type', [parent elements], {optional properties});
```

Possible types are point, line, circle, polygon, functiongraph, to name a few. For example, the call of

```
| var A = board.create('point', [1, 0]);
```

will create a free point initially at  $(1, 0)$  which can be dragged around. While dragging an element, all elements of the board are constantly updated.

If there is an additional point

```
| var B = board.create('point', [-1,-1]);
```

we can create a line through these points by

```
| var s = board.create('line', [A,B]);
```

Function graphs can be specified either as a JavaScript function or as a string containing the usual mathematical syntax.

```
| var f1 = board.create('functiongraph', [function(x){return x*x;}]);  
| var f2 = board.create('functiongraph', ["cos(x)"]);
```

A comprehensive documentation describing all available elements and all possible properties is available at the JSXGraph website<sup>47</sup>. In addition the JSXGraph wiki<sup>48</sup> contains many examples.

If one wants to avoid construction by programming JavaScript code, D. Drakulic has developed a user interface running in the web browser which exports the JSXGraph code<sup>49</sup>.

JSXGraph constructions can also be included in e-books based on the file format epub3<sup>39</sup>. Together with MathJax<sup>52</sup> for typesetting of mathematical formulae this paves the road to truly interactive mathematical e-textbooks.

### 3.3.2.2 Example: Euler line of a triangle

We close this section with an elaborated example how to use JSXGraph in a web page. It contains the well-known Euler line of a triangle (Fig. 23).

*Euler showed in 1765 that in any triangle, the orthocentre, circumcentre, and centroid are collinear.*

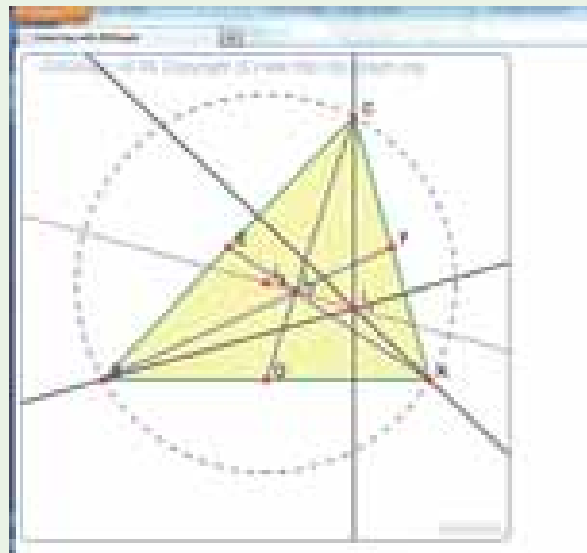

Fig. 23: Euler line of a triangle

First of all, in order to use JSXGraph, the JavaScript library has to be included into the HTML file. Further, it is advised to include a small CSS file jsxgraph.css.

## The HTML <head>

```
<html>
<head>
<title>Euler line with JSXGraph</title>
  <link rel="stylesheet" type="text/css"
    href="http://jsxgraph.uni-bayreuth.de/distrib/jsxgraph.css" />
  <script type="text/javascript"
    src="http://jsxgraph.uni-bayreuth.de/latest/jsxgraphcore.js"></script>
</head>
```

## Using an HTML element of JSXGraph

In the body part of the HTML one empty HTML object has to be reserved for JSXGraph.

```
<body>
  ...
  <div id="box_euler_line" class='jxgbox' style='width:600px;
    height:600px;'></div>
  ...
  <script type='text/javascript'>
    var board = JXG.JSXGraph.initBoard('box_euler_line', {
      boundingbox: [-1.5, 2, 1.5, -1], keepaspectratio:true
    });
  </script>
</body>
```

## Creating geometric elements

Now we can use our board object to construct new elements via `board.create()` commands. The available geometric elements are documented at the JSXGraph website<sup>47</sup>. For example the triangle for which the Euler line is constructed is created by the following commands.

```
// Triangle ABC
var A = board.create('point', [1, 0]),
    B = board.create('point', [-1, 0]),
    C = board.create('point', [0.2, 1.5]),
    pol = board.create('polygon', [A,B,C], {
      fillColor: '#FFFF00',
      borders: {
        strokeWidth: 2,
        strokeColor: '#009256'
      }
    });
```

The complete example "Euler line" including the source code is available at [http://jsxgraph.uni-bayreuth.de/wiki/index.php/Euler\\_line\\_source\\_code](http://jsxgraph.uni-bayreuth.de/wiki/index.php/Euler_line_source_code).

### 3.3.3 JessieCode

JessieCode is a scripting language developed to describe JSXGraph constructions. It uses datatypes and a syntax very similar to JavaScript and integrates the JSXGraph API in the language.

The intended use is in environments where JavaScript poses a security risk in the form of Cross Site Scripting (XSS) attacks, e.g. a website with user contributed content like a discussion board or a wiki. To allow advanced constructions some kind of scripting is required. There are approaches that deal with the issue by securing the host site from third party content<sup>33</sup>, but a solution that is easier to set up and maintain is preferable.

The language uses the JavaScript datatypes number, string, object, function, and null. Functions can be defined by function expressions only.

```
f = function (x) {  
    return x*3;  
}
```

#### Element creators

Creating elements in JSXGraph always involves the `board.create()` method. The first parameter of this method is the type of element we want to create, the second parameter is an array of parent elements, like coordinates for a point, or points for a line or a function for a plot. The third parameter describes the visual appearance of that element, e.g. colors and visibility.

In JessieCode for every element type there is a function that takes the contents of the parent array as its parameters. With this approach we get rid of a lot of overhead and can make constructions much more readable.

```
p = point(0,1);  
q = point (-1,-2);  
li = line(p, q);
```

The function call may be followed by objects containing attributes. The attribute objects can be combined in form of a list where the last appearance of an attribute defines the value.

```
p = point(0,1) " fillColor: 'blue' ";  
blue = "  
    fillColor: 'blue'  
";  
thick = "  
    strokeWidth: 8  
";  
q = point(1, 1) blue;  
r = point(3, 4) blue, thick;
```

It might be interesting to compare the Euler line example in JavaScript with the same example translated to JessieCode, which can be found online at

[http://jsxgraph.uni-bayreuth.de/wiki/index.php/Euler\\_line\\_source\\_code](http://jsxgraph.uni-bayreuth.de/wiki/index.php/Euler_line_source_code)

### 3.3.4 Sketchometry

The new dynamic geometry system (DGS) sketchometry is built on top of the JSXGraph library and utilises the JessieCode language to provide a graphical user interface (GUI). It allows the user to construct geometric objects and define their dependencies by simply drawing sketches of lines, circles, and points on the screen.



Fig. 24+25: Sketchometry in action

A graphical user interface has to meet different requirements for touch devices in comparison to mouse based devices. Mouse-travel paths have a different meaning on touch devices - the mouse can only produce relative movements of a virtual finger. Reaching the location of an interaction using the finger directly is much more natural and faster for the user. This influences the user interface design, e.g. the arrangement of buttons, the usage of popups, and the input of geometric objects.

Sketchometry consists of a minimal user interface in connection with a novel mixture of algorithms to interpret the user input and convert it into exact mathematical objects. Sketches and gestures are used to input geometric objects and their dependencies directly without the preselection of a specific construction tool from a toolbar. Sketchometry interprets the paths generated by sketches and gestures and enables constructing by natural interactions.



Fig. 26: The sketchometry "gallery" shows all locally stored constructions

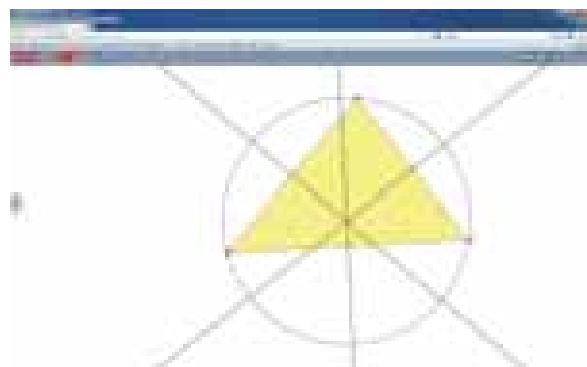

Fig. 27: The sketchometry construction board

In contrast, in most other DGS for constructing geometric objects, the user constantly has to use toolbar buttons. This may interrupt the users work cycle. Sketchometry breaks this behavior. The user does not have to select a tool - he just has to memorise few simple pre-defined figures, that when they are drawn on the board construct different objects.

Sketchometry is free to use, runs on all modern HTML5 browsers and is well suited for classroom demonstrations on an interactive whiteboard. But first of all, sketchometry is intended to be used by students in classroom. By purpose it does not have the amount of functionality easily available as offered by other dynamic geometry systems. But in many cases these programs are used by the teacher to prepare interactive demonstrations for the students. Rarely, students are expected to start constructing from scratch with these systems. On the contrary, sketchometry tries to revitalise an active participation of the students.

For the more ambitious user the GUI also incorporates JessieCode, which allows users to fine-tune their constructions and script certain actions on the board. By using this language it is also possible to do keyboard-only constructions, which means no mouse or other input mechanism is needed. Saving into local storage is done constantly and transparent to the user – there is no save button anymore. For external storage several cloud services can be used. At the time of writing, Dropbox, Google Drive, Skydrive and Ubuntu One are supported.

### Sketch recognition

While a sketch is drawn on the screen, several steps occur in the background.

At first, the gesture is analyzed by the  $\$N$ -algorithm<sup>28</sup> to recognize the shape of the figure and to provide a list of candidates of object types, which could be constructed.

Secondly already existing geometric objects, like points, lines and circles, which have been hit by the sketched curve, are collected.

Third, corners in the sketched curve are detected<sup>42, 44</sup>.

Finally, the list of construction type candidates is tested against the collection of hit objects and corners. Those candidates for which most of the collected objects make sense are kept, the other construction types are discarded.

That way the list with constructible elements gets narrowed down, until only one entry remains.

If there remains more than one candidate, the construction fails and the user has to repeat the sketch.



Fig. 28: From circle sketch ... Fig. 29: ... to the mathematical object



Fig. 30: Circle sketch using a point as centre Fig. 31: The resulting circle

### 3.3.5 Conclusion

JSXGraph, JessieCode and sketchometry enable dynamic mathematics on a great variety of devices from desktop computers to mobile devices. Small handheld devices are well suited for use in classroom and allow to use electronic material side by side with printed textbooks.

JSXGraph and JessieCode are intended to be used by software developers and e-book authors to create interactive content for web pages and e-books. Sketchometry is expected to be used by students in the classroom. It is the first step towards a natural user interface which allows a “hands-on” exploration of geometry.

## References

- 1 Cox, D., J. Little, and D. O'Shea: Ideals, Varieties, and Algorithms. Second Edition, Springer 1997
- 2 Lawrence, J. D.: A Catalog of Special Plane Curves. Dover Publications, New York 1972
- 3 Pech, P.: Selected Topics in Geometry with Classical vs. Computer Proving. World Scientific, Singapore 2007
- 4 Recio, T. and M. P. Vélez: Automatic Discovery of Theorems in Elementary Geometry. J. Automat. Reason. 12 (1998), pp. 1-22
- 5 Shikin, E. V.: Handbook and Atlas of Curves. CRC Press, Boca Raton 1995
- 6 Wang, D.: Elimination Methods. Springer-Verlag, Wien New York 2001
- 7 Weitzenböck, R.: Math. Zeitschrift. 5 (1919), pp. 137-146
- 8 program CoCoA, freely distributed at <http://cocoa.dima.unige.it> (last visited 10/12/2012)
- 9 program Epsilon, freely distributed at <http://www-calfor.lip6.fr/~wang/epsilon/> (last visited 10/12/2012)
- 10 Kenderov, P. and E. Sendova: Towards Enhancing the Inquiry Based Education. In: Proceedings of the UNESCO International Workshop Re-Designing Institutional Policies and Practices to Enhance the Quality of Education through Innovative Use of Digital Technologies (QED), Sofia 2012, pp. 56-70
- 11 Sendova, E.: Identifying Computer Environments and Educational Strategies to Support Creativity and Exploratory Learning. In: Davies, G. (ed.): Teleteaching'98 Distance Learning, Training and Education, Proceedings of the XV IFIP World Computer Congress, Vienna/Austria and Budapest/Hungary 1998
- 12 Sendov, B. and E. Sendova: To Discover America of Yours: Learning Mathematics in a Logo Based Environment. In: E. Calabrese (ed.): Proceedings of the Third European Logo Conference, Parma, Italy 1991, pp. 343 - 354
- 13 Resources of the Fibonacci project  
<http://www.math.bas.bg/omi/Fibonacci-en/archive.htm> (last visited 08/25/2012)
- 14 Chehlarova, T. and E. Sendova: Something Uncommon about the Common Fractions  
<http://www.math.bas.bg/omi/Fibonacci-en/archive.htm> (last visited 08/25/2012)
- 15 Chehlarova, T.: Elementary and Basic Constructions in Geometry  
[http://www.math.bas.bg/omi/docs/Elementarni\\_7\\_ENf/index.htm](http://www.math.bas.bg/omi/docs/Elementarni_Osnovni_7_ENf/index.htm) (last visited 08/25/2012)
- 16 Papert, S.: What is Logo? And Who Needs It? Introduction to Logo Philosophy and Implementation. LCSJ 1999, pp. V-XVI
- 17 Kynigos, C.: Half-Baked Logo microworlds as boundary objects in integrated design. Informatics in Education, 6(2), 2007, pp. 335-358
- 18 Chehlarova, T.: Folding a Rectangular Napkin  
<http://www.math.bas.bg/omi/docs/salfetka/index.htm> (last visited 08/25/2012)
- 19 Chehlarova, T. and E. Sendova: Enhancing the inquiry-based learning via reformulating classical problems and dynamic software. Годишник на НПУ "М.П.Драгоманов", Киев, Украина 2012



- 20 Boytchev et. al.: IT for Innovative Educational Environments: Exploring, Authoring and Programming. In: Auer, M. (ed.): The Challenges of Life Long Learning ICL 2009, Kassel University Press, Villach, Austria, 2009, pp. 434-444
- 21 Sendov B., R. Filimonov and D. Dicheva: A System for Teaching Plane Geometry. Proceedings of the Second International Conference "Children in the Information Age", Sofia 1987, pp. 215-226
- 22 Geomland, <http://sunsite.univie.ac.at/elica/PGS/INDEX.HTM> (last visited 10/02/2012)
- 23 Elica, <http://www.elica.net/site/index.html> (last visited 08/25/2012)
- 24 Sendova, E. and P. Boytchev: Reflecting on the reflection  
[http://www.math.bas.bg/omi/docs/Reflecting\\_on\\_the\\_reflection.pdf](http://www.math.bas.bg/omi/docs/Reflecting_on_the_reflection.pdf) (last visit 10/02/2012)
- 25 Sendova, E. and B. Sendov: Using Computers in School to Provide Linguistic Approaches to Mathematics: A Bulgarian Example. In: Friedman, E. and A. Lesgold (eds.): Machine-mediated Learning, 4(1), 1994, Lawrence Erlbaum Associates, Inc., pp. 27-65,
- 26 Sendov, B. and E. Sendova: East or West - GEOMLAND is BEST, or Does the Answer Depend on the Angle? In: A.A. diSessa, C. Hoyles, and R. Noss (eds.): Computers and Exploratory Learning, NATO ASI Series, Computer and Systems Sciences, Vol. 146, Springer - Verlag, Berlin 1995, pp. 59 – 79
- 27 Kolcheva, M. and E. Sendova: Learning Rather Than Being Taught: A New Style of Studying Plane Geometry. In: Knierzinger A. and M. Moser (eds.): Informatics and Changes in Learning. Proceedings of the IFIP Open Conference 1993, Gmunden, Austria, Session 2.1, pp. 19-22
- 28 Anthony, Lisa and Jacob O. Wobbrock: \$N\$-protractor: a fast and accurate multistroke recognizer. In: Proceedings of the 2012 Graphics Interface Conference. Toronto, Ont., Canada: Canadian Information Processing Society, 2012 (GI '12)
- 29 Drijvers, Paul: Digital technology in mathematics education: Why it works (or doesn't). In: 12th International Congress on Mathematical Education, Seoul, 2012
- 30 Ehmann, Matthias, Carsten Miller and Alfred Wassermann: Dynamic Mathematics with GEONExT – New Concepts. In: 4th European Workshop on Mathematical & Scientific e-Contents, Trondheim, 2008
- 31 Gerhäuser, Michael, Bianca Valentin and Alfred Wassermann: JSXGraph - Dynamic Mathematics with JavaScript. In: The International Journal for Technology in Mathematics Education 17, 2010
- 32 Gerhäuser, Michael, Bianca Valentin, Alfred Wassermann and Peter Wilfahrt: JSXGraph - Dynamic Mathematics Running on (nearly) Every Device. In: Electronic Journal of Mathematics and Technology 5, 2011, February. <http://www.radford.edu/ejmt> (last visited 10/19/2012)
- 33 Google: Google Caja. September 2012. - <https://developers.google.com/caja/> (last visited 10/19/2012)
- 34 Hoyles, Celia and Jean-Baptiste Lagrange (eds.): Mathematics education and technology – rethinking the terrain. The 17th ICMI study, Springer, Dordrecht 2010
- 35 Kaput, James and Patt Thompson: Technology in mathematics education research: The first 25 years in JRME. 25, 1994, pp. 676 -684
- 36 Kay, Alan C.: A Personal Computer for Children of All Ages. In: Proceedings of the ACM annual conference – Volume 1. New York, NY, USA : ACM, 1972
- 37 Lederman, Josh: Education chief wants textbooks to become obsolete. October 2012. - <http://news.yahoo.com/education-chief-wants-textbooks-become-obsolete-184205690.html> (last visited 10/19/2012)

- 38 Norman, Donald A.: Natural user interfaces are not natural. In: interactions 17, 2010, May, Nr. 3, pp. 6 -10
- 39 The International Digital Publishing Forum: EPUB. 2011. - <http://idpf.org/epub> (last visited 10/19/2012)
- 40 Wassermann, Alfred: The Challenge of a New Hardware Generation to Mathematics Education. In: Bianco, Tamara and Volker Ulm (eds.): Mathematics Education with Technology, Experiences in Europe. Augsburg: Universität Augsburg, 2010
- 41 Wikipedia: Natural user interface. September 2012. – [http://en.wikipedia.org/wiki/Natural\\_user\\_interface](http://en.wikipedia.org/wiki/Natural_user_interface) (last visited 10/19/2012)
- 42 Wolin, Aaron, Brian Eoff and Tracy Hammond: ShortStraw: A Simple and Effective Corner Finder for Polylines. In: SBM, 2008, pp. 33-40
- 43 Xie, Charles: Natural learning interfaces. September 2012. - <http://blog.concord.org/natural-learning-interfaces> (last visited 10/19/2012)
- 44 Xiong, Yiyang and Joseph J. Jr. LaViola: Revisiting ShortStraw - Improving Corner Finding in Sketch-Based Interfaces. In: Grimm, Cindy and Joseph J. Jr. LaViola (eds.): SBM, Eurographics Association, 2009
- 45 JSXGraph: <http://www.jsxgraph.org> (last visited 10/19/2012)
- 46 JSXGraph Applications: <http://jsxgraph.uni-bayreuth.de/wp/home/applications> (last visited 10/19/2012)
- 47 JSXGraph Dokumentation: <http://jsxgraph.uni-bayreuth.de/docs> (last visited 10/19/2012)
- 48 JSXGraph Wiki: <http://jsxgraph.uni-bayreuth.de/wiki> (last visited 10/19/2012)
- 49 JSXGraph GUI by D. Drakulic: <http://eudzbenici.rs.ba/tools/JSXGUI/> (last visited 10/19/2012)
- 50 JessieCode: <http://github.com/jsxgraph/JessieCode> (last visited 10/19/2012)
- 51 Sketchometry: <http://www.sketchometry.org> (last visited 10/19/2012)
- 52 MathJax: <http://mathjax.org> (last visited 10/19/2012)

## Photo Credits

Fig. 24: created by Matthias Ehmann, Bayreuth, Germany

Fig. 25: created by Carsten Miller, Bayreuth, Germany

# 4 IBME in Schools: Overview and Examples in International Contexts

---

## 4.1 Inquiry-based mathematics education in primary school: Overview and examples from Bavaria/Germany

Volker Ulm

### 4.1.1 Heterogeneity in primary school

Heterogeneity in school is not a new phenomenon. In 1807 the educationalist and philosopher Johann Friedrich Herbart (1776 – 1841) noticed: *"The difference of heads is the greatest obstacle for education in school. To ignore that is the basic deficiency of the school system."*

Children already differ with respect to their mathematical knowledge and understanding when they enter the school system. Some first graders have clear notions of numbers up to 1,000 and the decimal system, while others struggle with numbers up to five. It is a pedagogical illusion to think of "homogeneous learning groups" in class.

How should the school system deal with this reality of heterogeneity? One possibility could be the attempt to offer education for the "average pupil", i.e. addressing the "middle level" in class. This might be motivated by the pedagogical aim to reduce differences between the pupils and to bring all children to the same level. But is this fair to the individual child or is it effective?

Another possible view on heterogeneity is to regard it as something very normal, not as an obstacle, but even as an advantage or a chance for learning in class. If one accepts that pupils are different and will always be different in the future, the pedagogical question arises how to support and develop the individual abilities of each child in a classroom setting.

A way that proved to be quite successful in the Fibonacci project can be described as "natural differentiation" with "substantial learning environments" [11](#), [12](#), [13](#), [8](#). All pupils get the same learning offer, but the topic has an inherent complexity so that each child can primarily work at his own individual level. Each pupil can begin doing mathematics and experience a sense of achievement. Weaker students find rich fields to develop their mathematical understanding and expand their abilities; high performers work at their level and get deeper insights. The common exchange of ideas and results in groups and in class intensifies the pupils' mathematical understanding and fosters their communication skills. The following sections provide a theoretical basis for this didactical concept and provide examples to illustrate it.

As an introduction, let us look at a concrete example from mathematics education at a third grade primary school in Germany where the pupils were around nine years old. The teacher prepared eight "Fibonacci Series" tasks and presented them using papers posted to the blackboard and a worksheet (see below). The pupils were asked to work on the tasks individually and in small groups. They were told to write all their considerations, calculations and results on white sheets of paper and stick them to the respective task on the blackboard (Fig. 1). The pupils' results were visible to all of the children and to the teacher. This proved to be an ideal basis for further communication in and between the groups, and for the class as a whole.

In the first task, the children explored the special properties of number series like "2 – 3 – 5 – 8 – 13" or "8 – 3 – 11 – 14 – 25" and came up with similar series themselves using other starting numbers. By observing the groups and talking with them the teacher was able to make sure that every child understood the construction principle of these series – an essential basis for further calculations and explorations.

With the further tasks (see below), the children varied the first number, the second number or both starting numbers in several ways and investigated the effects on the fifth number of the series. The children could choose which task they wanted to work on, but the teacher recommended dealing with the tasks in the given order. This offered many possibilities to calculate, to explore relationships and underlying mathematical patterns, to describe observations and conjectures, to discuss and to argue. To put it briefly, the children worked mathematically in a very comprehensive way. The openness of the learning environment made it possible for the children to do mathematics at their own individual level. According to the natural heterogeneity of the class, the pupils' results, which had been posted on the blackboard (Fig. 1), showed a broad variety of calculations and discoveries.



Fig. 1: Blackboard with the tasks and the pupils' results

$$\begin{array}{l}
 4-5-9-14-28 \\
 5-4-3-12-22 \\
 6-7-13-25-35 \\
 7-6-13-29-42 \\
 1-9-10-19-29 \\
 9-1-10-11-21
 \end{array}$$

Fig. 2: Cedric's calculations

Cedric, a weaker pupil, dealt with task e) (see below) and explored the effects on the series when interchanging the two starting numbers. Although he made four mistakes in his additions (Fig. 2), he did make a discovery and wrote it on his paper: "The numbers 9, 13, 10 are always the same."

$$\begin{array}{l}
 8-3-77-26-43 \\
 3-8-17-25-42 \\
 4-6-10-16-26 \\
 6-4-10-14-24 \\
 6-10-16-26-42 \\
 10-6-16-22-38
 \end{array}$$

Fig. 3: Laura's calculations

Laura also worked on task e) and interchanged starting numbers of the series (Fig. 3). She discovered a very substantial pattern, and wrote below her calculations: "The difference of the first and the second number is equal to the difference of the fifth numbers."

Natalie engaged herself in task g) and looked for series where the fifth number is 100 (Fig. 4). She began with the starting numbers "50 – 10" and varied them systematically until she found the series "20 – 20 – 40 – 60 – 100". After several more attempts of variations she found "17 – 22 – 39 – 61 – 100" as a second possibility. Taking into account her results from tasks b) and c), she finally found a principle how to produce many further series with the fifth number being 100: Decrease the first number by 3 and increase the second number by 2 or, alternatively, increase the first number by 3 and decrease the second number by 2.

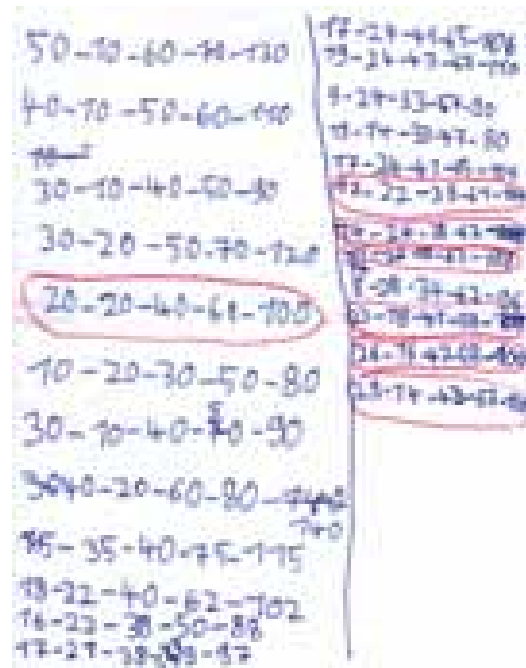

Fig. 4: Natalie's series

With all these sheets from the children posted on the blackboard, the lesson ended with presentations and a class discussion of the pupils' ideas and results. In this phase the teacher's main task was to organise and moderate the communication processes and to sum up key results.

This introductory example shows how the natural heterogeneity in class can be met by natural differentiation and inquiry-based learning. In the next section we will develop a basic theoretical foundation and work out general principles of this didactical concept.

## Fibonacci Series

### a) Explore Fibonacci series

What are the special properties of the following two series?  
 Invent such series yourself.  
 Choose any two starting numbers.

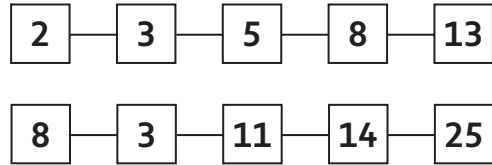

### b) Vary the first number

What happens to the fifth number if you increase the first number by 1, 2, 3, ...?  
 What happens to the fifth number if you decrease the first number by 1, 2, 3, ...?  
 Write down examples and describe your observations.

### c) Vary the second number

What happens to the fifth number if you increase the second number by 1, 2, 3, ...?  
 What happens to the fifth number if you decrease the second number by 1, 2, 3, ...?  
 Write down examples and describe your observations.

### d) Vary both starting numbers

What happens to the fifth number if you increase both starting numbers by 1, 2, 3, ...?  
 What happens to the fifth number if you decrease both starting numbers by 1, 2, 3, ...?  
 Write down examples and describe your observations.

### e) Interchange both starting numbers

What happens to the fifth number if you interchange both starting numbers?  
 Write down examples and describe your observations.

### f) Equal starting numbers

What happens to the fifth number if you take two equal starting numbers?  
 Write down examples and describe your observations.

### g) Target number 100

Look for starting numbers so that the fifth number is 100.  
 Try to find several series with the fifth number 100. Describe your observations.

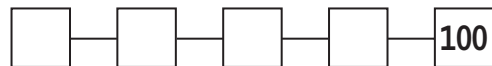

### h) Even and odd target numbers

Look for starting numbers so that the fifth number is even.  
 Look for starting numbers so that the fifth number is odd.  
 Describe your observations.

### 4.1.2 Aspects of learning

The ultimate goal of all efforts of mathematics education is for students to learn. In this context “learning” is meant in the broadest sense and includes the development of knowledge and understanding as well as attitudes, behaviour and moral values. Therefore, a short glance at the nature of learning is quite useful. The following aspects of learning have been formulated by Pedagogical Psychology e.g. <sup>9, 5</sup>. They provide a background for the subsequent sections.

- Learning is a *constructive* process. Knowledge and understanding cannot simply be transferred from teachers to students. According to theories of constructivism, people construct their knowledge and understanding by interpreting personal perceptions based on individual prior knowledge and prior understanding. Cognitive psychology describes learning as a process of construction and modification of cognitive structures. From the view of neurosciences, learning is the construction of neuronal networks. Connections between neurons develop and change. All these theoretical approaches stress the constructive nature of learning and have several consequences in common:
- Learning is an *individual* process. Learning takes place inside the mind of each learner. One will not find two human brains that are exactly the same. Each person has individual cognitive structures – a different neural network. Thus, learning processes differ from person to person.
- Learning is an *active* process. Cognitive activity means working with the content in mind, viewing it from different perspectives and relating it to the existing network of knowledge.
- Learning is a *self-organised* process. The learner is at least partially responsible for the organisation of his individual learning. The degree of responsibility may vary in the phases of planning, realising or reflecting on learning processes.
- Learning is a *situational* process. It is influenced by the learning situation. A meaningful context or a pleasant atmosphere can foster learning; fear can hamper it.
- Learning is a *social* process. On the one hand, the socio-cultural environment has great impact on educational processes. On the other hand, learning in school is based on interpersonal cooperation and communication between students and teachers.
- Finally, learning is *driven by examples*. We will use three examples to illustrate this.

Let us think of a term from everyday life, like “apple”. We all know what an apple is and have general knowledge about apples. But how did we acquire this knowledge? Children usually gain this knowledge through examples in their first years of life. Children don’t get definitions of apples like “An object is called an apple if ...”. They construct general knowledge on apples by generalising experiences with concrete objects. The same is true for many notions of everyday life like “window”, “chair”, “dog”, etc.

A second example, which is closer to mathematics, is grammar. Children learn how to speak correctly in their native language not by explicitly learning grammar rules. They learn how to construct sentences through examples, by trial and error. Grammar rules are descriptions of what is learnt through examples.

This general principle of learning is valid for mathematics as well. There are lots of rules and laws in school mathematics: the commutative law for addition and multiplication, the rule for dividing fractions, etc. Pupils gain understanding of such rules by exploring examples that carry the general patterns. The general rules are descriptions of what is learnt through examples.

### 4.1.3 Inquiry-based learning

Learning is a very complex phenomenon and there are many ways human beings can learn. Psychology and pedagogy developed sophisticated models of learning and differentiations of types of learning. Although the Fibonacci project focuses on *inquiry-based learning*, we must keep in mind that this is only one manner of learning related to a specific point of view on this complex phenomenon.

How can inquiry-based learning be described? It is characteristic that the learner

- explores a topic
- which is to some extent new and complex for him
- through individual cognitive activity.

The learner should feel a certain *complexity* and *novelty* of the topic, so that tasks cannot be done just by applying existing knowledge and well-known strategies. The topic should be challenging *for the learner*, e.g. for the pupil in primary school, and it should be worth dealing with for a certain amount of time. Of course, the result may be well known in mathematics in general. Pupils can explore mathematical results that have been known to mankind for thousands of years in an inquiry-based way.

Typically, *exploring* a topic means, e.g.

- looking at examples, varying given situations,
- connecting new phenomena to existing knowledge,
- formulating observations and conjectures,
- structuring situations and detecting patterns,
- describing results and giving reasons for them.

This notion emphasises *individual cognitive activity*. Of course, this can be combined with and supported by hands-on activities. Moreover, cooperation in a group and exchange with others can also be incorporated. Since learning is a social process, individual and cooperative learning should even be intertwined closely in class. We will come back to that in [section 4.1.6](#) when we consider methodology.

### 4.1.4 Learning environments for IBME

After taking a glance at “learning”, we now look at the other side of the medal: “teaching”. A very fundamental question of the school system is how to initiate and support students’ learning effectively – particularly in the classroom setting. This is a very complex problem that has no simple answer. Mankind developed many teaching methods, each with their own specific advantages and disadvantages.

The Fibonacci project aims at large-scale dissemination of inquiry-based mathematics education. It is clear that this is only one teaching and learning method among many others. It would be one-sided and ineffective to teach exclusively according to just this method. However, a certain shift of mathematics education towards more inquiry and more self-organised and cooperative learning for students seems to be a reasonable approach to overcoming well-known problems of mathematics education as revealed by international studies such as TIMSS and PISA.

In this and the following two sections, we will elaborate on the didactic concept of inquiry-based mathematics education. Considering the aspects of learning in [section 4.1.2](#), we start with a model that seems to be quite natural for describing teaching and learning processes in school.



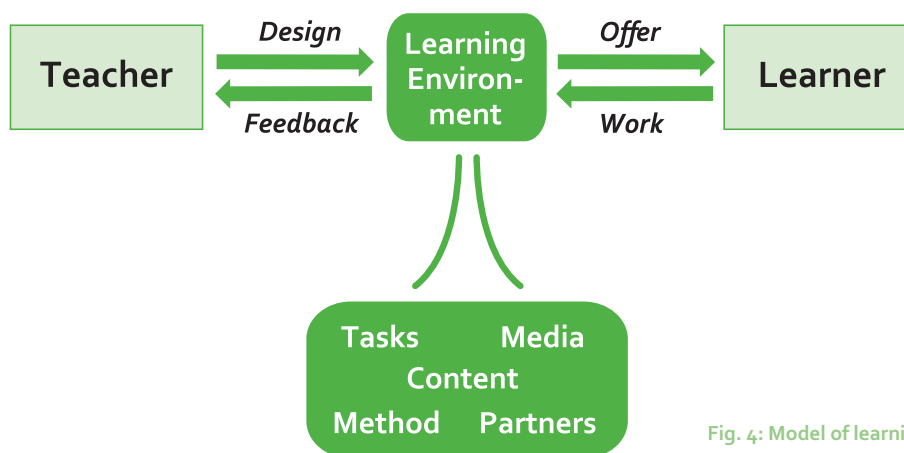

Fig. 4: Model of learning environments

According to constructivist points of view, the teacher cannot put knowledge directly into the learners' heads. The *learning environment* is the essential link between the teacher and the learner. This notion includes five components: the *tasks* for the learner working with the *content*, the *method* of teaching and learning, the arrangement of *media*, and the social situation with the teacher and other learners as *partners* for learning.

It is the teacher's responsibility to design the learning environment. So he offers a basis for the learner's work. This allows the teacher to get feedback about both the learner and the learning environment.

This model is based on and extends the didactical concepts of "substantial learning environments" by Wittmann<sup>11, 12</sup> or "strong learning environments" by Dubs<sup>2</sup>.

This model does of course simplify reality – as any model does. However, the function and the strength of models is to reveal basic structures of complex situations. On the one hand, this model of learning environments shows that the teacher cannot enforce or steer students' learning directly. The teacher cannot influence the students' minds directly. This might be disappointing or even frustrating for teachers. On the other hand, if we think positively, it is the teacher's task to design learning environments in order to initiate and encourage the students' learning.

The aspects of learning noted in section 4.1.2 imply fundamental consequences for the design of learning environments: Tasks should be problem-based with necessary openness for inquiry-based learning. They should offer meaningful examples and contexts to view situations from multiple perspectives. The teaching methods should make the learners work individually, actively, self-organised and cooperatively. The students should experience mathematics as a field of explorations and discoveries. And they should present and discuss their ideas and results. See also the *Background Resource* "Inquiry in Mathematics Education" (<http://www.fibonacci-project.eu/resources>).

#### 4.1.5 Tasks for IBME

The tasks for the pupils are a core element of learning environments. They carry mathematical situations and give impulses for thinking and working mathematically. This raises the question: Are there tasks that are especially good for inquiry-based mathematics education? Surely, tasks by themselves cannot be "good" or "bad", since it is crucial how they are used in actual teaching and learning situations. However, there are attributes of tasks that offer a certain potential for initiating and supporting inquiry-based learning in school.

- Tasks for inquiry-based learning should be *open* at least to some extent, i.e. they should outline a mathematical situation that offers different approaches to and various possibilities for doing mathematics.

- Tasks should be *mathematically rich*, i.e. they should refer to mathematical content of a certain depth and complexity for the learner. Thus, it should be worthwhile for the learner to engage himself with the tasks some amount of time. They should offer possibilities to do mathematics in a comprehensive way, to increase or to deepen personal mathematical insights and understanding.
- Tasks should be *challenging* and motivating for the pupils. This is a basic requirement for the students' engagement in tasks.
- Tasks should be *easily accessible* to all children, i.e. each child should have the possibility to begin working with the tasks and experience a sense of achievement in doing mathematics.
- Tasks should *support working at different levels*, i.e. weaker pupils should have opportunities to expand their abilities and achieve specific results. On the other hand, gifted students should be able to work at their more advanced levels.

It is part of the teacher's professional competence to develop and to provide adequate tasks for his pupils and to integrate these tasks in inspiring learning environments. See also [chapter 2](#) about the *basic patterns* (key features of inquiry pedagogy).

#### 4.1.6 Teaching methods for IBME

Besides tasks and content, the teaching method is another key element of learning environments. How can we organise mathematics education to effectively support inquiry-based learning? There is a wide variety of methodical concepts. The following table shows just one example. However, this example seems to be quite natural for inquiry-based mathematics education in a classroom setting. It structures lessons in four phases and combines constructivist notions of learning (see [section 4.1.2](#)) with realities in school:

<p><b>a) Individual work</b></p> <p>Since learning is an individual process, students initially work on their own. They are faced with the necessity to explore the content, to activate their prior knowledge, to develop ideas and to make discoveries.</p>
<p><b>b) Cooperation with partners</b></p> <p>Learning is a social process. It is very natural for students to discuss their ideas with partners in small groups and work on problems cooperatively. This communication helps to order thoughts and to get more ideas. Meanwhile, the teacher can stay in the background or turn his attention to individuals.</p>
<p><b>c) Presentation of ideas</b></p> <p>After having worked individually and in groups, the students present their ideas and discuss them in class. The different contributions reveal multiple aspects of the topic so it can be viewed from different perspectives. Moreover, students develop presentation, communication and argumentation skills.</p>
<p><b>d) Summary of results</b></p> <p>Finally, the students' results are summarised and possibly expanded by the teacher. It is his task to introduce mathematical conventions and to consider curricular regulations. But since the students have already explored the new content on their own paths, they are more likely able to integrate the teacher's explanations into their individual cognitive structures.</p>

This methodical concept combines individual learning with cooperative learning in both small groups and the class as a whole in a very natural way. Of course, this concept is not really new. It has been described in a similar way by different expressions like “Think – Pair – Share”<sup>4</sup> or “I – You – We”<sup>3</sup>; see also [section 2.3](#).

The basic feature of this concept is the natural combination of different phases of learning in class, with each of them having specific functions for mathematics education: The students have the freedom to do mathematics on their own and to develop individual understanding. They discuss and present their ideas and results, which helps them develop skills for communicating and arguing mathematically. The teacher can add structure to the students’ ideas, make things more clear, explain mathematical content and summarize results, e.g. on the blackboard (or whiteboard).

Here again we have to consider that this methodical concept is only one of many methods. It would be one-sided and imbalanced if mathematics education were organised only in this way. Lively mathematics lessons should draw on a broad spectrum of teaching methods.

#### 4.1.7 Example for arithmetic: Windows on the hundreds chart

We illustrate the didactical concepts of the previous sections using two examples that are tasks for mathematics education in primary school<sup>6, 7</sup>. They fulfil the quality criteria set up in [section 4.1.5](#), but we have to keep in mind that tasks are only one part of learning environments. In the classroom, they have to be combined with a teaching method that supports inquiry-based learning and thus they have to be integrated in an inspiring learning environment.

The hundreds chart is a tool in primary school that gives orientation in the range of natural numbers up to 100. It represents these numbers in a clearly structured way. In the tasks below the children choose numbers from the hundreds chart using windows cut out of paper and calculate with the numbers in the window. This not only increases their calculation skills, but also gives them a chance to explore the structure of the hundreds chart.

If you put *Window 1*, the window with three fields in a straight line, on the hundreds chart,



you will find that the number in the middle field multiplied by three is the same as the sum of all three numbers. Thus, you will find all multiples of 3 between 6 and 297 except for  $3 \cdot 10$  and  $3 \cdot 91$ .

In *Window 2*, which consists of three fields in an L-shape, you have to consider several different cases. Depending on how the window is put on the hundreds chart, you get:



three times the number in the corner + 9,



three times the number in the corner - 9,



three times the number in the corner + 11 or



three times the number in the corner - 11.

Thus, using this window, you get sums between 14 and 289.

Adding up the numbers in *Window 3* provides the following results:





odd numbers from 45 to 359 or



all even numbers from 18 to 386 that are not divisible by 4.

### Summing the numbers in *Window 4*

 provides only even results between 28 and 376.  

In order to find the smallest or greatest result for each window, the children have to understand the structure of the hundreds chart. They must develop a strategy and consider all possibilities of turning and flipping the windows.

Moving the windows systematically provides results that change according to certain rules. The sum of the numbers within the windows with three fields

- will increase by 3, if you move the window to the right (because each of the three numbers increases by one),
- will decrease by 3, if you move the window to the left (because each of the three numbers decreases by one),
- will increase by 30, if you move the window down (because each of the three numbers increases by 10),
- will decrease by 30, if you move the window up (because each of the three numbers decreases by 10).

The results of the windows with four fields follow the same rules, increasing or decreasing by 4 and 40, respectively.

In order to find three or four numbers that add up to a given result, children have to work strategically and purposefully by using what they already know about the change of sums when the window is moved in certain directions.

“Windows on the hundreds chart” can be a topic in class for two to three lessons. In an introductory phase, the class as a whole can place *Window 1* on the hundreds chart. The sum of the three numbers is calculated. Afterwards, the children should suggest what happens if you put the window in another place. (“The result increases”, etc.) The teacher should tell the pupils that they are allowed to turn and rotate the window. This common starting phase should guarantee that each child has understood the basic principle of working with the windows.

Then, the pupils could work individually and cooperatively on the tasks on the worksheet. The teaching unit can be structured according to the methodical concept depicted in [section 4.1.6](#). It might be useful for the children to write down their calculations, observations, conjectures and results on white sheets of paper and stick them on the blackboard or a wall in the classroom like in [Fig. 1](#). This makes all products visible to all the other children and to the teacher, and it may serve as a basis for further communication between the groups and in the whole class. The teacher could introduce and moderate the final presentation, discussion and reflection phase by asking questions such as: Which exercises did you work on? What calculations did you do? What did you notice? What smallest or greatest result did you find? Which discoveries of other children surprised you? What else do you want to verify or explore by yourself?

## Windows on the Hundreds Chart

You can do experiments with the hundreds chart.

1	2	3	4	5	6	7	8	9	10
11	12	13	14	15	16	17	18	19	20
21	22	23	24	25	26	27	28	29	30
31	32	33	34	35	36	37	38	39	40
41	42	43	44	45	46	47	48	49	50
51	52	53	54	55	56	57	58	59	60
61	62	63	64	65	66	67	68	69	70
71	72	73	74	75	76	77	78	79	80
81	82	83	84	85	86	87	88	89	90
91	92	93	94	95	96	97	98	99	100

Cut out the four rectangles. Cut out the white squares, too. You get "windows" for the hundreds chart.

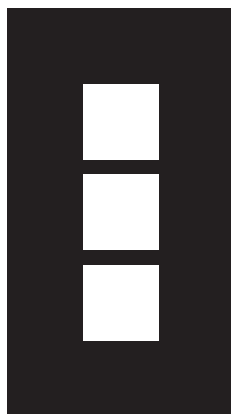

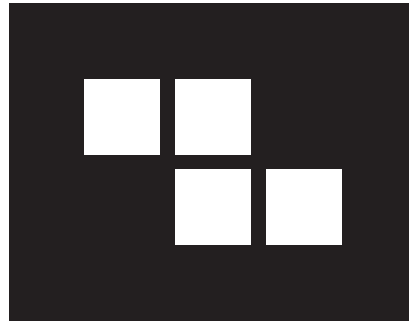
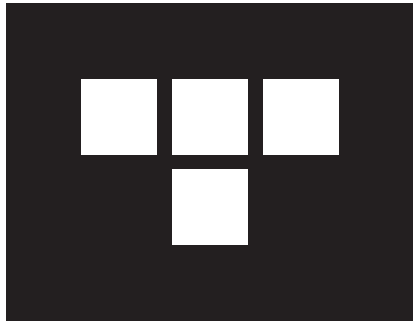

## Explorer's tasks

a) Take one of the four windows and put it on the hundreds chart. Add up the numbers you see in the window.

You can turn and rotate the window. Can you find the smallest and the greatest possible result?

b) Put the window on the hundreds chart. Add up the numbers you see in the window.

Move the window one field to the right or to the left. What is the sum now?

Compare your results. Can you figure out a rule? Write down your observations.

What happens if you move the window one field up or one field down?

c) Try to put the window on the hundreds chart so that all numbers add up to 54. Then try to find the sum 90. Write down your calculations.

Think of other results and try to find numbers in the window that add up to these results.

Are there any sums that you cannot add up to?

d) Take the other windows and explore the questions above for these windows.

### 4.1.8 Example for geometry: Quadruples

Assembling cubes to form new shapes, classifying these shapes and constructing plans for such shapes develops spatial awareness and geometrical skills. Moreover, this topic emphasises the playful aspect of doing mathematics.

There are eight different ways to connect four cubes to quadruples:

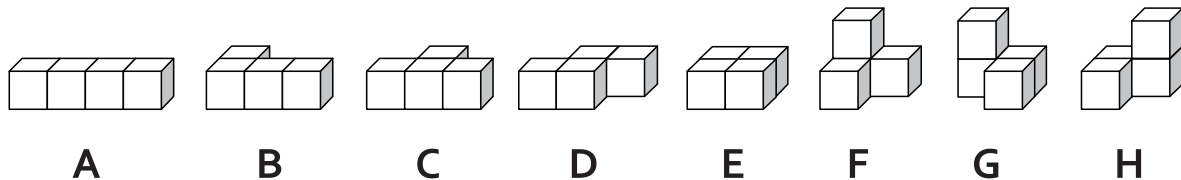

All other possibilities can be found by rotating these eight combinations. Due to the small number of possible combinations, it is reasonable to let the children find all possible combinations by themselves, to compare quadruples, to recognize the same or similar quadruples and to find an argument for what is a complete list of all combinations.

The activities with the cube quadruples can be done in two to three lessons. It is important to start with a simple task where each child constructs quadruples. By actively handling the cubes (e.g. wooden cubes), each child can experience rotating his combinations. Pupils will notice that a quadruple may look different in various positions, but it still has the same arrangement of the cubes. Standard wooden cubes are appealing due to the material, and they are geometrically clear due to their flat faces. But the problem is that the quadruples tend to fall apart while being rotated. You can fix this by using an adhesive to glue the cubes together, which can be removed later. A more stable option, but less exact in form, is to use cubes that can be plugged together.

Argumentation is of great importance as the children decide whether the quadruples are equal or different and discuss the handling of their combinations: "When I rotate my quadruple it looks exactly like yours. So they are not different, but the same."

If the teacher specifies that there are eight different quadruples, the children have a clear goal. But this could lead to frustration if they do not find all eight possibilities. It is more interesting to let children explore by themselves, maybe leaving the task in class for a longer amount of time so that they can think more about it. If the students are content with their results too quickly, the teacher can keep them thinking by showing them a "new" quadruple.

When drafting construction plans, one should discuss in class that for each quadruple a base can be chosen and that on each square of this base the respective height should be written. Construction plans can be illustrated like this:

For quadruple A:

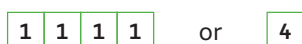

For quadruple B:



There are three construction plans for quadruple B and there are two construction plans for quadruples A, C and E. For quadruples D, F, G and H there is only one construction plan (excluding reflections and rotations). The total sum of the numbers in the construction plans is always four, as this sum is the number of the cubes.

Note that quadruples B, C, D, F, G and H could also be positioned so that the base is smaller than the bird's eye perspective, e.g.:

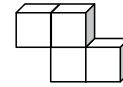

To draw up the construction plans the class must decide whether "floating" cubes are allowed. Does every cube have to lie on the ground or on another cube? Here children may find new construction plans for such situations, e.g. for the quadruple above:

2-1	2	1
-----	---	---

Here "2-1" means: "There are two cubes, but the bottom one (on the ground level) is missing." Note that  $(2-1)+2+1$  again equals four, which is also an appropriate arithmetic description of the situation.

When the children have drawn several construction plans, they can be encouraged to organize their plans. One possible sorting is:

- Construction plans with the highest height of one. (Construction plans for A, B, C, D and E are suitable.)
- Construction plans with the highest height of two. (Construction plans for B, C, F, G and H are suitable.)
- Construction plans with the highest height of three. (Construction plan for B is suitable.)
- Construction plans with the highest height of four. (Construction plan for A is suitable.)

Children can also distinguish construction plans with 1, 2, 3 or 4 squares in the base, etc. By doing this, children can also understand why there cannot be more than eight distinct quadruples.

- If the four cubes are arranged in a plane, the only possibilities are all four in a long row (A), one cube next to the remaining three (B and C), or two cubes next to the other two (D and E).
- For combinations in which three cubes are on one level and the fourth on the level above, the fourth cube can sit on any of the three other cubes. Thus, there are three possibilities (F, G and H).
- As soon as the quadruple is three cubes high, the quadruple can be rotated such that it is only one cube in height.

The children hone their spatial perception skills and their ability to think in three dimensions by making oblique drawings of the quadruples. It may be helpful for the children to have the quadruple they are drawing in front of them. It can also be helpful to colour the front faces of the cubes in one colour, the right faces and other sides in different colours.

Covering quadratic planes with quadruples is done by trial and error. Here the children will discover quickly that the quadruples F, G and H are not suitable, as they cover two levels in each position. With the quadruples A, B, C and E, the  $4 \times 4$  squares can be covered. Quadruple D always creates squares in the corners that can no longer be covered.

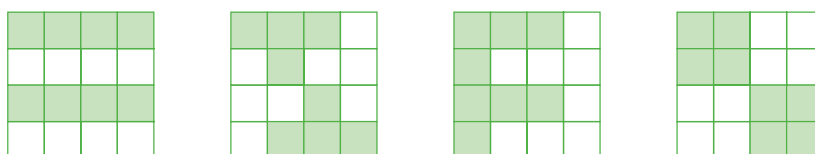



# Quadruples

## Exploring quadruples

Quadruples consist of four identical cubes that are stuck together at complete sides. Two examples are:

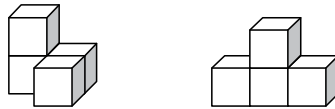

- Make quadruples by yourself. Compare with your partner.
- How many different quadruples can you find?
- How many different quadruples can you find in the class?
- Create "families" of quadruples that belong together. Invent names for the "families". What are the specific characteristics of each family?
- Examine the quadruples for symmetry.
- Laura would like to paint the quadruples. For which ones does she need the most paint, for which ones the least paint? Explain.

## Construction plans

- This construction plan is for the given quadruple.



Draw construction plans for other quadruples in your workbook.

- Is there only one possible construction plan for each quadruple, or is there more than one?
- What do all construction plans for quadruples have in common?
- Try to arrange the construction plans in groups.
- Which construction plans belong to the same quadruple? Colour them in the same colour.

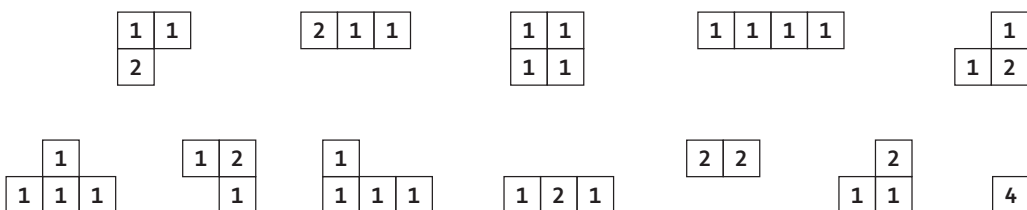



## Drawing quadruples

a) Copy these quadruples on the gridded paper in your workbook.

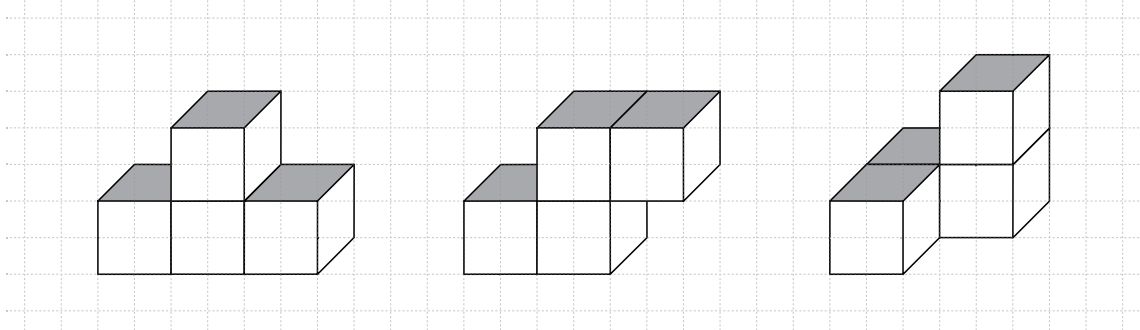

b) Explain how to make an oblique drawing on gridded paper.

c) Choose other quadruples and make oblique drawings in your workbook. Compare the pictures with your neighbours.

## Covering squares

a) Can you cover the area of a 4x4-square with four equal quadruples? Make sketches.

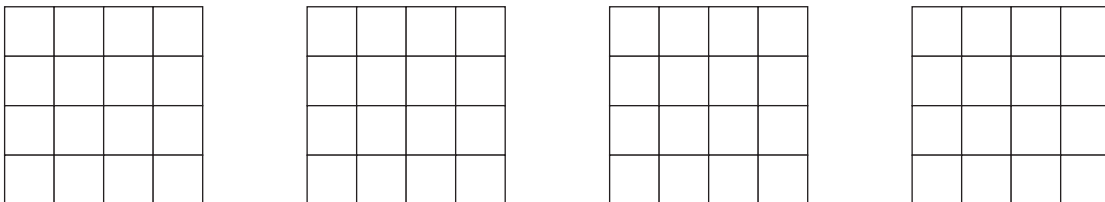

b) Can you cover a 4x4-square with four different quadruples? Make sketches.

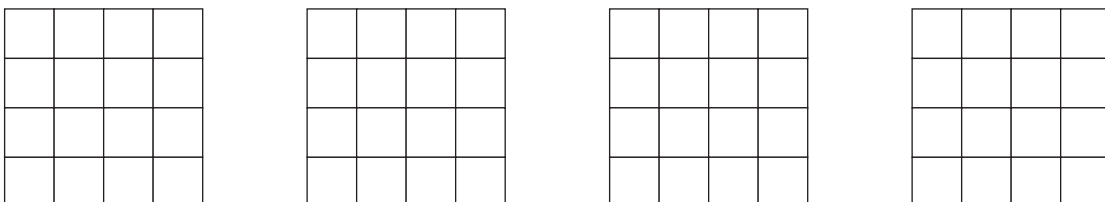

c) Which quadruples are suitable for covering the squares? Which ones are not? Give reasons.

## 4.2 The current state of IBME in the Czech Republic

*Libuse Samkova*

This article presents an overview of the current state of IBME in the Czech Republic and of the changes that have occurred as a result of our participation in the Fibonacci project.

### 4.2.1 IBME from the perspective of the Czech Framework Educational Programme

First, we would like to introduce you to the basic concept of education in the Czech Republic. This concept is based on teachings of Comenius (the principle of the illustrative nature of teaching)<sup>14</sup>, and on John Dewey's logic of science (through practical work and active experimentation we create a theory of experience)<sup>15, 16</sup>.

The obligatory document for teaching at primary and secondary schools in the Czech Republic is the Framework Education Programme (FEP). Let us quote some passages from this programme.

The FEP for primary and lower secondary education says:

*An important part of mathematical education consists of non-standard application tasks and problems that may be largely independent of the knowledge and skills of school mathematics, but in which logical thinking is required. These tasks should be present in all thematic areas throughout basic education.*

*Pupils learn to deal with problem situations and tasks of daily life, to understand and analyse the problem, to organise data and conditions, to draw sketches of situations, to solve optimisation problems.*<sup>18</sup>

And the FEP for upper secondary education says:

*Mathematical education helps cultivate abstract and analytical thinking, develops logical judgment, and teaches clear and factual reasoning aimed at finding objective truths rather than defending one's own opinion.*

*The focus of the instruction lies in mastering the ability to formulate a problem, along with a strategy to solve it, in actively mastering mathematical tools and skills, and in cultivating the capability of applying these skills.*<sup>4</sup>

These quotes show that IBME education complies with the basic principles of mathematical education at Czech primary and secondary schools.

### 4.2.2 Twin Centre Budweis and its background

The University of South Bohemia in Ceske Budejovice (Budweis) joined the Fibonacci project very recently in September 2011. The staff of the Twin Centre Budweis is located at the Faculty of Education, at the Department of Mathematics. As twinning partner of the University of Bayreuth, the centre focuses mainly on inquiry in mathematics.

We decided to concentrate on lower and upper secondary schools. The reason is clear: We personally know skilled secondary school teachers who have cooperated with our university for years. The initial portfolio of our Fibonacci schools consists of two elementary schools (grades 6 – 9), a grammar school ("gymnazium"), an integrated technical and vocational school, and a secondary vocational school of mechanical engineering and construction.

Although most Czech teachers know almost nothing about IBME, some of them have used the methods of IBME in their teaching for years. These 'naturally IBME' teachers had priority in our Fibonacci team. The Fibonacci team was strengthened by selecting teachers who have worked with us continuously for a long time: Six in-service teachers with an excellent set of skills for IBME were trained within the initial training session as mentor IBME teachers.

All of our Fibonacci mentors teach mathematics plus one or two other subjects such as biology, descriptive geometry, IT, chemistry or technical training. We wanted to take advantage of this interdisciplinary background, so we prepared the following two fundamental tasks for them:

**Task No. 1:**

*The mentor teachers were asked to review their non-mathematical subjects to identify where mathematics is used as a tool. Then, they were guided to suggest how to link the two subjects.*

The objective of this task is clear: The teachers (and therefore their students) should understand the mathematical ideas in a form and context that is useful for the non-mathematical subjects.

In addition to this multidisciplinary approach, TC1 Budweis initiates the development of learning environments on a very important topic: "Improving financial literacy". For details see [section 4.3](#).

**Task No. 2:**

*The mentor teachers should review their mathematical activities to identify where inquiry activities can be applied.*

In both cases, the mentor Fibonacci teachers (with help of the TC staff) compose learning environments with appropriate methodological materials and test them in their classes. The mentor teachers also help other teachers with the use of learning environments in other classes.

Materials already harmonised and tested are posted on our project web <sup>20</sup>. These materials are in Czech; the most interesting are also available in English. Some of the most complicated environments are accompanied by samples of students' completed worksheets (scanned).

In-service mathematics teachers not (yet) involved in the Fibonacci project get informed about these IBME learning environments at in-service teacher trainings, at teachers' workshops, seminars and conferences, by Czech educational journals, by colleagues involved in the Fibonacci project, etc. Pre-service mathematics teachers at our university have IBME activities included in their university courses. For details see [sections 5.1](#) and [5.2](#).

### 4.2.3 Czech teachers and their experience

We interviewed all teachers involved in the Czech part of the Fibonacci project and asked them about their experience with IBME teaching. They described the main advantages of this way of teaching and learning as

- it supports activation methods of education, individual activities, and group cooperation;
- it can be implemented in various phases of the educational process (motivation, discovering new facts, deepening knowledge, application of acquired knowledge, acquired knowledge in new contexts, etc.).

The teachers mostly see disadvantages of this way of teaching and learning in the fact that

- the examples of IBME, which include an experimental component, are time consuming – not only in terms of time needed for teacher preparation, but also in terms of time needed for their realisation in the classroom;
- these experimental examples often require a corresponding lower number of pupils, which can be achieved by dividing the classes for the lessons – an arrangement that is not always feasible.

In summary, the methods of IBME are very appropriate ways to teach. However, they must be properly incorporated due to their major demands. The use of IBME methods highly depends on the teacher's ability and willingness to use them.

#### 4.2.4 Digest of learning environments created within the Fibonacci project

The following examples are inspired by the work of teachers involved in the Fibonacci project, namely Hana Mahnelova from Gymnazium Nymburk (Examples No. 1 and 4), Kvetuse Mrazova from Vltava Basic School Ceske Budejovice (Example No. 2), and Eva Vortelova from Integrated Technical and Vocational School Ceske Budejovice (Example No. 3). The worksheets were successfully tested in classroom environments and harmonised.

Other interesting examples of learning environments created within the project can be found in section 4.3, in<sup>19</sup> and at our Fibonacci website<sup>20</sup>. Learning environments on the web are accompanied by a list of additional information (recommended student age, time requirements, GeoGebra files, etc.) as well as a ready-to-use student worksheet. The website is continuously updated.

#### Example No. 1 "Circumference of a circle – The discovery of the Ludolphine number"

This example shows the possibility of combining classical measurement experiments with computer experiments prepared ahead of time. The example is also a good illustration of how to link school theory with everyday practice.

The teacher brings various round objects (paper wheel, coin, can, cylinder, cup, plate, pot, thick marker, tube, water pipe, bracelet, wall clock, hoop, etc.) to the classroom along with several measuring devices (ruler, set square, tape measure, carpenter's ruler, calliper, string, strip of paper, compass, etc.). The round objects have different sizes and the measuring devices use different units (cm, mm, inch, feet ...).

The last part of the task takes place on computers using a GeoGebra file prepared ahead of time.

#### TASKS FOR STUDENTS:

##### TASK 1: RADIUS vs. DIAMETER (discussion)

*How can you accurately measure the radius or the diameter of an object?  
Suggest at least two different methods.*

*What tools are used to take these measurements in practice?*

*Which is easier: measuring the radius or the diameter?*

*In geometry, why do we usually use the radius?*

During the discussion students realise that there is a big difference between the school concept of a circle (described by the radius and drawn using a compass adjusted to the given radius) and a practical concept (measuring not the radius, but the diameter).

**TASKS FOR STUDENTS:**

**TASK 2: PRACTICAL EXPERIMENT**

Choose six different objects. For each of the objects, measure the circumference and the diameter. Write your results in the table.

Object	Circumference $c$ (in cm)	Diameter $d$ (in cm)	$c \cdot d$	$c : d$

Fill in the last two columns of the table using your calculator (two decimal places).

What happens if you change centimetres to different units of measurement?

Formulate a hypothesis based on the data in the table.

It is important to have the fourth column in the table for comparison and to get the students thinking.

Students should be well aware that the fifth column does not depend on the units of measurement, but the fourth column does.

### TASKS FOR STUDENTS:

#### TASK 3: COMPUTER EXPERIMENT

We will now model the same situation with the help of dynamic geometry software like GeoGebra.

A circle is given with radius  $r$  and centre  $S$ , and two points  $A, B$  on the circumference of this circle.

You may move points  $A, B$  all around the circle. These points determine the circular arc, whose length is measured and mentioned in the accompanying interactive text.

You may also change the radius of the circle, using the green slider in the upper right corner.

Watch the results of the measurement. Formulate a hypothesis based on the data.

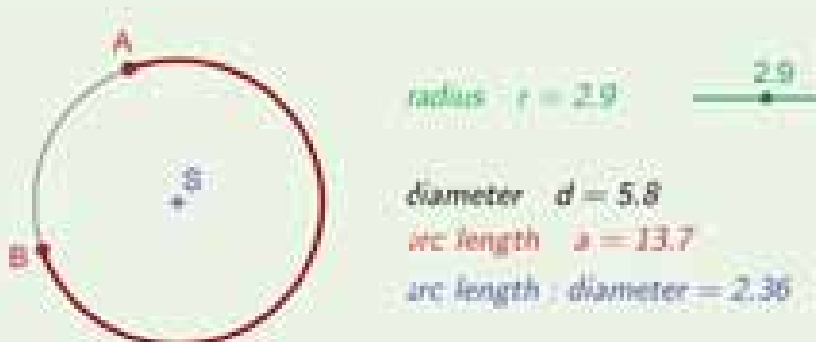

Fig. 5: Dynamic worksheet for task 3

Tasks 2 and 3 can be solved individually or in pairs, depending on the number of tools and computers available in the classroom.

Since GeoGebra is free software and students can easily download it to their home computers, task 3 can also be given as homework – with the teacher’s GeoGebra file being part of the homework assignment. For the convenience of both teachers and students, the file is also available as a dynamic web worksheet<sup>21</sup>.

With skilled students and enough time the file can be created by students themselves as a part of the task.

### Example No. 2 “Aspect ratios in a right-angled triangle”

This example is a targeted preparation for trigonometric functions.

### TASKS FOR STUDENTS:

#### TASK 1: SIDES and ANGLES (discussion)

Are there some relations between lengths and angles of sides in a right-angled triangle?



The discussion is primarily to motivate students. Students probably don't have any idea about the relation. The teacher might write a YES/NO table on the board and count students' opinions.

**TASKS FOR STUDENTS:**

**TASK 2: CALCULATIONS**

Calculate the ratios  $\frac{a}{b}$ ,  $\frac{b}{c}$ ,  $\frac{a}{c}$ , and  $\frac{b}{a}$  in the following triangles, round the results to 2 decimal places.

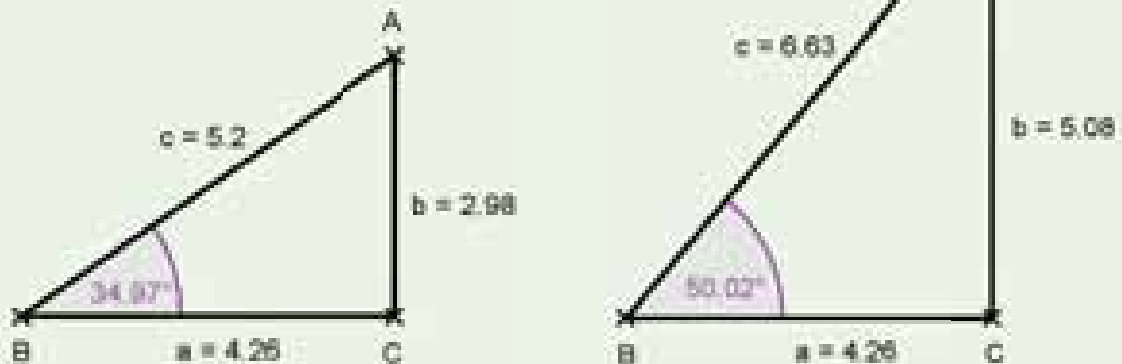

The students get several different worksheets, each with two non-similar right-angled triangles. The worksheets differ in the length of sides only; angles are the same. Neighbouring students receive different worksheets.

Each student completes the worksheet individually, with help of a calculator. Then the students jot down their results belonging to the first triangle in the worksheet, and the teacher writes the results on the blackboard – it might look like this:

1 <sup>st</sup> triangle	$a$	$b$	$c$	$\frac{a}{c}$	$\frac{b}{c}$	$\frac{a}{b}$	$\frac{b}{a}$
Worksheet No.							
1	4.26	2.98	5.2	0.82	0.57	1.43	0.70
2	2.96	2.07	3.61	0.82	0.57	1.43	0.70
3	3.62	2.53	4.42	0.82	0.57	1.43	0.70
4	5	3.5	6.1	0.82	0.57	1.43	0.70
5	5.46	3.82	6.67	0.82	0.57	1.43	0.70

Initially, students are surprised that they get the same results on different worksheets (i.e. for different triangles). Then they are encouraged by the teacher to find out whether the triangles on different worksheets have something in common. After a while they will discover the matching angles.

The second triangle's report follows, with the same course.

The last task is a computer experiment: The teacher brings a prepared GeoGebra file to the classroom.

### TASKS FOR STUDENTS:

#### TASK 3: COMPUTER EXPERIMENT

Now we will model the same situation using the dynamic geometry software GeoGebra.

Here is a triangle **ABC** with a right angle in **C**.

You may change the length **a** using the slider in the upper left corner, the other sides will change automatically to keep all angles of the triangle unchanged. All sides of the triangle are automatically measured, ratios calculated and mentioned in the interactive text.

You may move point **A** upwards to change angle  $\beta$  and see what happens with the ratios.

### Goniometric functions

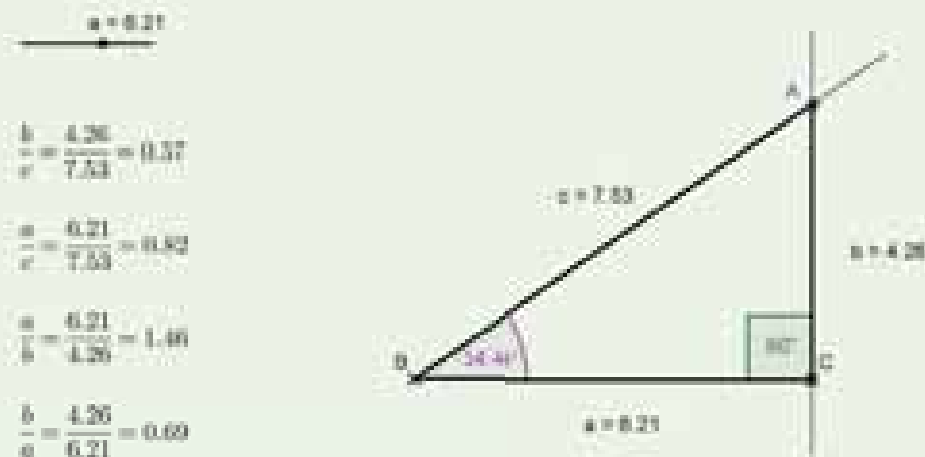

Fig. 6: Dynamic worksheet for task 3

The teacher may also prepare a GeoGebra file that allows changing the right-angled triangle into an oblique triangle to see what happens with the ratios in this case.

### Example No. 3 "Dams and their role during floods – Characteristics of linear functions"

This example shows a very topical usage of linear functions in a real-life situation. Summer floods have been a major problem in our area in recent years. The worst one was ten years ago, when the centre of Ceske Budejovice was flooded almost to a height of 1 metre. Students will remember the experience well and be interested in the topic of floods.

**TASKS FOR STUDENTS:**

**TASK 1: THE ROLE OF DAMS DURING FLOODS (discussion)**

*What is the role of dams during floods?*

*How long can the dam protect the region from the flood?*

*Which dam is important for your town during floods?*

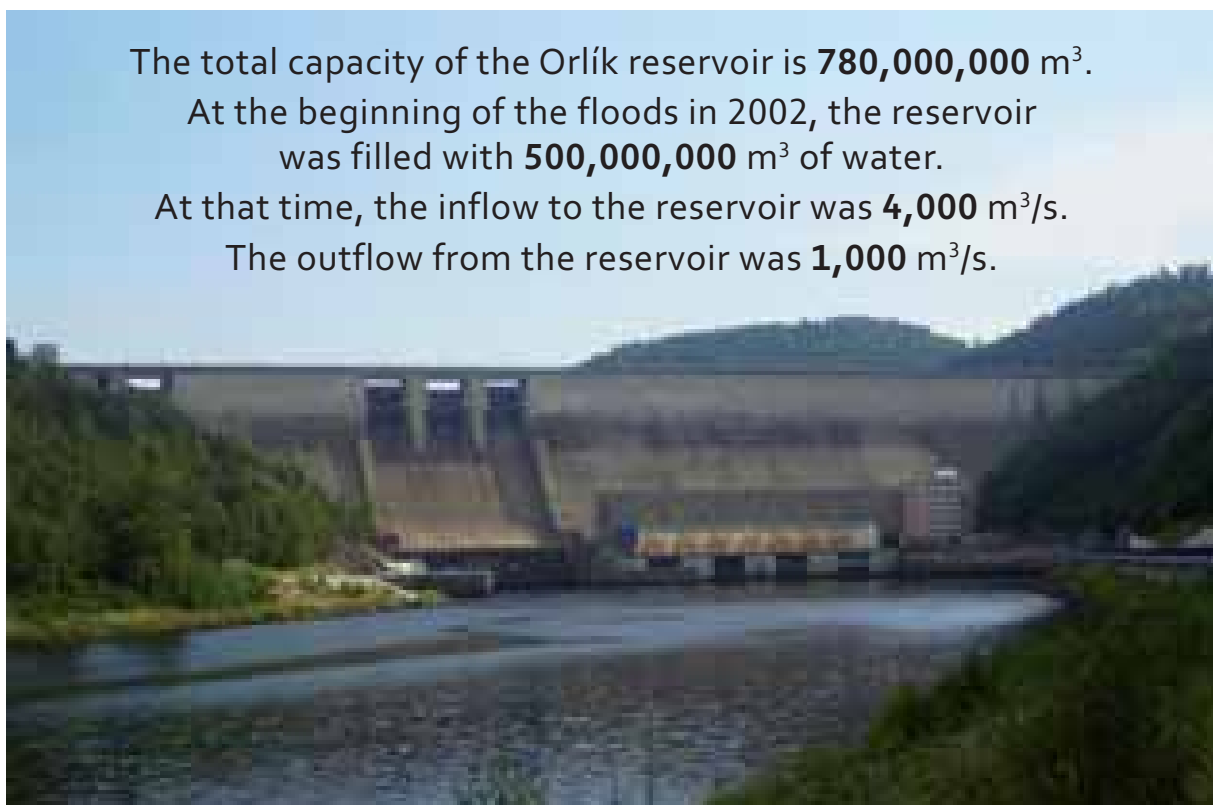

The total capacity of the Orlik reservoir is **780,000,000 m<sup>3</sup>**.  
At the beginning of the floods in 2002, the reservoir  
was filled with **500,000,000 m<sup>3</sup>** of water.  
At that time, the inflow to the reservoir was **4,000 m<sup>3</sup>/s**.  
The outflow from the reservoir was **1,000 m<sup>3</sup>/s**.

Fig. 7: Dam of Orlik reservoir

**TASKS FOR STUDENTS:**

**TASK 2: CALCULATIONS**

*How much water flowed into the reservoir in one hour?*

*How long did it take to fill the Orlik reservoir during the 2002 floods?*

*How could the time it takes to fill the reservoir be prolonged?*

*Suppose that the outflow is doubled, i.e. increased to 2,000 m<sup>3</sup>/s. How long would it take to fill the reservoir in this case?*

**TASKS FOR STUDENTS:**

**TASK 3: PLOTS and CALCULATIONS**

Suppose that the Orlik reservoir satisfies the following conditions:

- (1) The reservoir is empty; inflow is  $2,000 \text{ m}^3/\text{s}$ , outflow  $1,000 \text{ m}^3/\text{s}$ .
- (2) The reservoir is filled with  $650,000,000 \text{ m}^3$  of water; inflow is  $2,000 \text{ m}^3/\text{s}$ , outflow  $1,000 \text{ m}^3/\text{s}$ .
- (3) The reservoir is filled with  $500,000,000 \text{ m}^3$  of water; inflow is  $4,000 \text{ m}^3/\text{s}$ , outflow  $1,000 \text{ m}^3/\text{s}$ .
- (4) The reservoir is filled with  $500,000,000 \text{ m}^3$  of water; inflow is  $2,000 \text{ m}^3/\text{s}$ , outflow  $1,000 \text{ m}^3/\text{s}$ .
- (5) The reservoir is filled with  $500,000,000 \text{ m}^3$  of water; inflow is  $3,000 \text{ m}^3/\text{s}$ , outflow  $1,000 \text{ m}^3/\text{s}$ .
- (6) The reservoir is filled with  $500,000,000 \text{ m}^3$  of water; inflow is  $1,000 \text{ m}^3/\text{s}$ , outflow  $2,000 \text{ m}^3/\text{s}$ .

For each option, find a rule and a domain of a function expressing the dependence of the amount of water in the reservoir on the time in hours or in days, respectively.

Draw a graph that shows all the options and illustrates the forecast for the next 48 hours or next 7 days, respectively.

A graphical solution for a 7-day forecast created in GeoGebra:

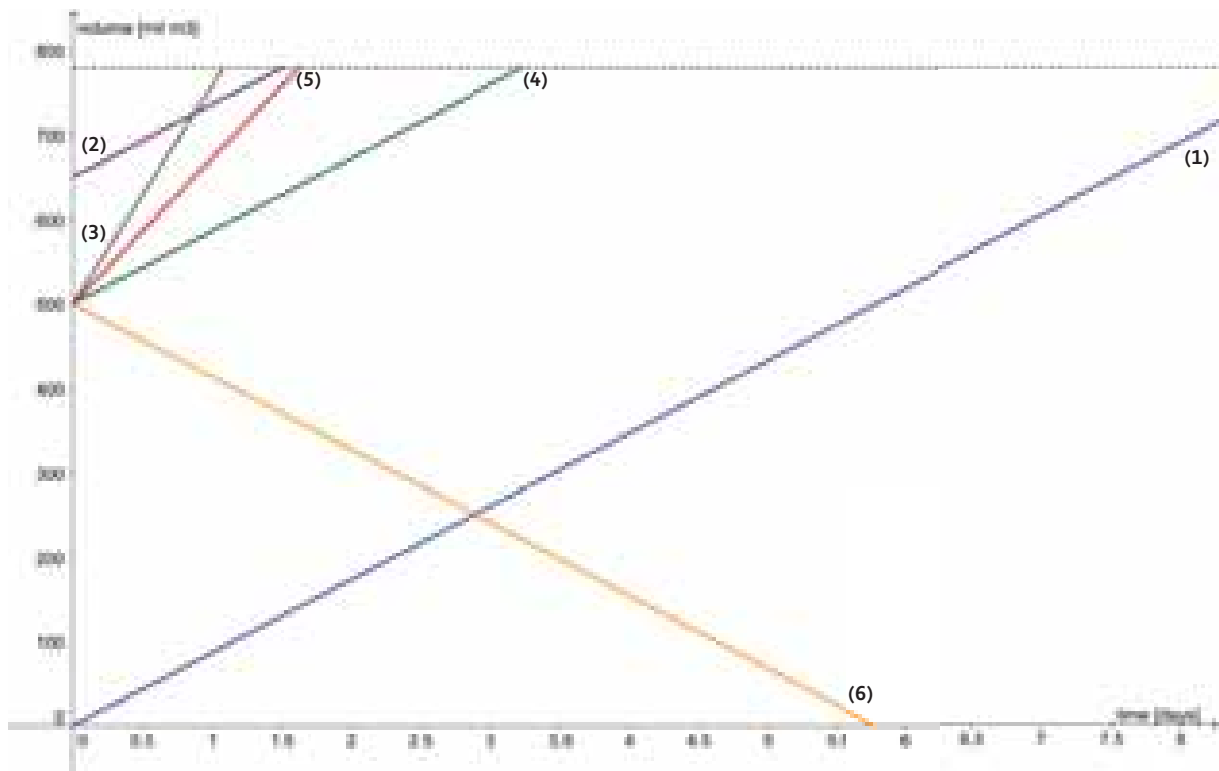

Fig. 8: Water in the reservoir - 7-day forecast

Students should be able to analyse the principle of the reservoir, convert the inflow and the outflow between different units ( $\text{m}^3/\text{s}$ ,  $\text{m}^3/\text{hour}$  and  $\text{m}^3/\text{day}$ ), and choose the best suitable units in various situations. They also should be able to identify when the reservoir is completely full (or empty) with the corresponding situation in the graph of a linear function.

Skilled students may draw a graph for situations when the inflow/outflow is not constant. For example: When the outflow doubles for 10 hours, the inflow is reduced by half after 20 hours, etc.

#### Example No. 4 “Searching for common features of graphs – Characteristics of functions”

This example leaves the process of inquiry entirely to students. They do not receive any guidance or advice.

The worksheet is intended for use when first introducing the topic of “functions” in upper-secondary schools. **Tasks 1** and **2** can be developed individually or in pairs; **task 3** is prepared for students who are fast and skilled to work on individually. The worksheet is completed during a broad discussion of the students’ final results.

##### TASKS FOR STUDENTS:

*Functions express the dependence of one variable on another (e.g. the dependence of average daily temperature on time, of mileage on speed, of the volume of supply on price, etc.) and reflect the relationship between quantities in various disciplines. For better orientation in functions, we can organise them into groups according to certain common features. To do this properly, we need to formulate the distinguishing features of behaviour of functions – their characteristic features.*

##### TASK 1: LOOKING FOR FEATURES (individual work)

*The following figures show the dependence of variables in graphical form, through the graph of a function. Examine each figure carefully, and describe all characteristic features that you can see.*

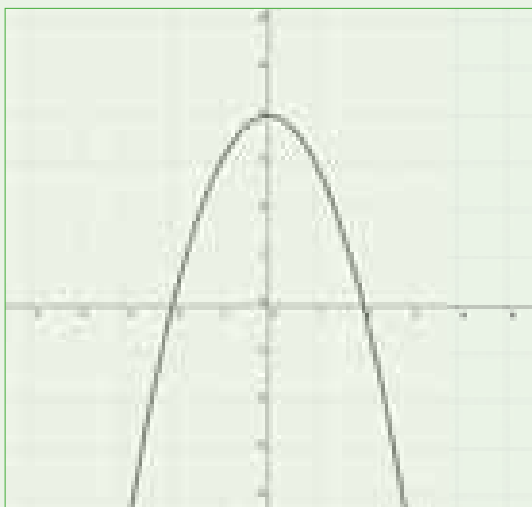

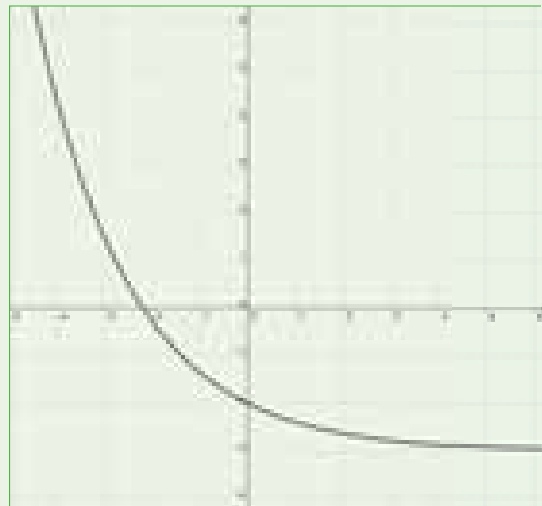
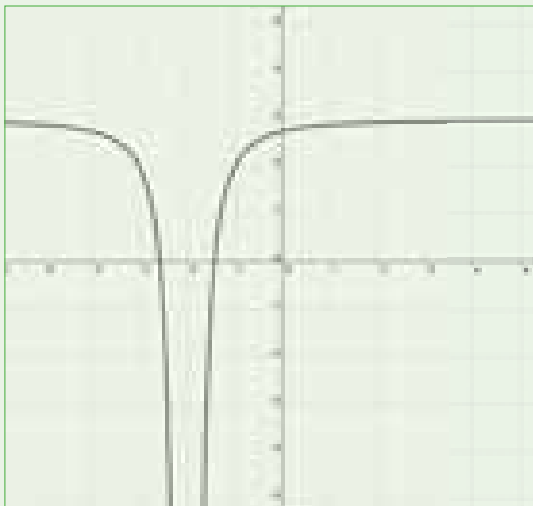
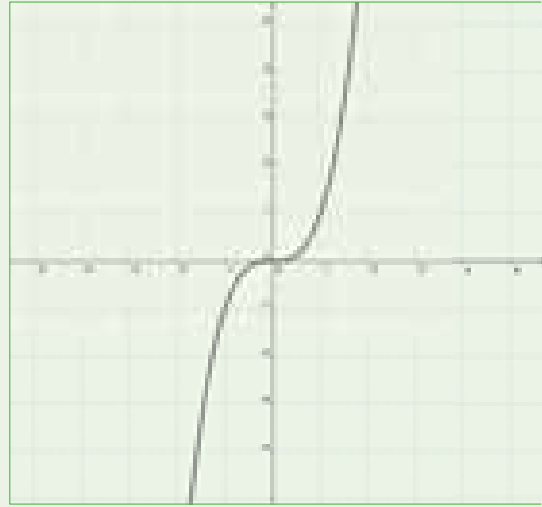
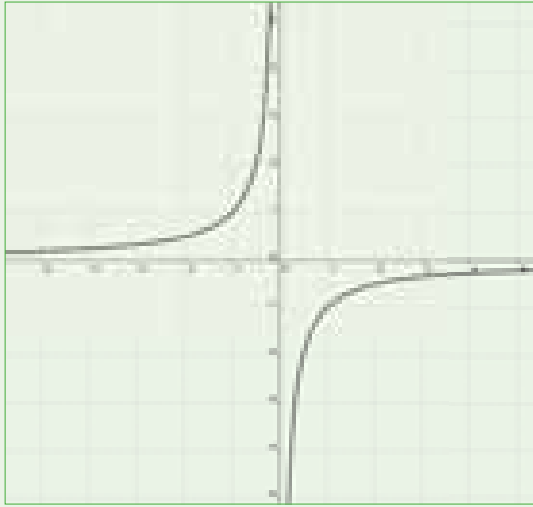

**TASKS FOR STUDENTS:**

**TASK 2: GENERALISATION**

*Try to generalise which features are important for working with functions and for their proper grouping.*

**TASKS FOR STUDENTS:**

**TASK 3: IN ANOTHER CONTEXT**

*Which of the features from TASK 1 and 2 can you derive from a prescription of a function  $y = (x+1)^2$ ? Do not use the graph of the function, just the prescription!*

The worksheet is followed up by proper definitions of basic properties of functions: domain, range, bounded values, intersections with axes, symmetry (even, odd function), monotony, injectiveness, local and global extremes (minimum, maximum), convexity, continuity, etc.

#### 4.2.5 IBME at Czech vocational schools

As mentioned in the general introduction, two of our Fibonacci schools are secondary vocational schools: The Integrated Technical and Vocational School in Ceske Budejovice (ITVS) and the Secondary Vocational School of Mechanical Engineering and Construction in Tabor (SMEC). ITVS is intended for future carpenters, plumbers, painters, bricklayers, joiners, locksmiths and chimneysweeps. These students take part in three-year apprenticeships without a school-leaving exam and begin working in their respective fields immediately after finishing school. Since this three-year apprenticeship is the lowest upper-secondary type of education in the Czech Republic, there are many lower performing students in these classes.

SMEC is quite different. It also teaches future carpenters, bricklayers, joiners and machinists in three-year apprenticeships without a school-leaving exam. But they also teach future designers, builders and engineers in four-year study programmes with a school-leaving exam, and these students are generally expected to continue their studies at a technical university.

We have excellent experience with the implementation of IBME in mathematics classes at these vocational schools: As for apprentice classes, we have several IBME environments already successfully tested there, and the response has been very positive. For instance, "Dams and their role during floods – Characteristics of linear functions" (see example No. 3 from section 4.2.4), "Where to fill the tank of our family car – The real-life use of linear functions", and "Home electricity consumption and costs – elementary statistics in practice". You can find all of these examples on our Fibonacci website <sup>20</sup>. These topics are real-life oriented and students like to explore them. These types of problems help students understand the importance of math lessons in school and can motivate them to participate actively in class. The family car topic was even inspired by a student's conversation a teacher heard during a break. Moreover, the second and third topics deal with financial literacy issues. These topics are not just valuable with regard to curricula – they also teach important (financial) lessons that both students and their parents can use in everyday life. Parents become more interested in what is happening at school and more specifically in their children's math lessons. The prospective domestic debate on tanking a family car or on electricity costs and consumptions can strengthen the relationship between children and their parents while fostering a sense of shared responsibility for family finances.

On the other hand, future designers, builders and engineers must be good in geometry and highly skilled and experienced in working with computers. The same is true for their teachers. That is the reason why we use SMEC as a basis for creating and testing complex IBME projects focused on ICT and geometry issues. One of these is the project "Can you fairly share a Coke with a friend? – Estimates and calculations of volume ratios of a cone". For details see <sup>20</sup>.

##### A FRAGMENT FROM THE "CONE PROJECT"

*Which of these cones contains more water?*

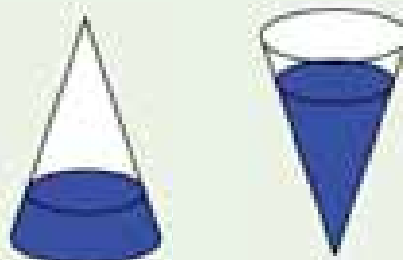

**Conclusion:** We strongly recommend the inclusion of secondary vocational schools into the IBME implementation process.



## 4.3 IBME in teaching and learning financial literacy topics – selected teaching methods for financial education

*Roman Hašek, Vladimíra Petrášková*

### 4.3.1 Introduction

Financial issues provide many opportunities to practise methods of inquiry-based mathematics education (IBME). Selected examples classified according to the teaching methods used, e.g. the problem, situation or project method, will be presented. The article is supplemented by the financial literacy learning environments; student worksheets plus methodological comments for teachers, created within the Fibonacci project.

It is necessary to acquire some knowledge and skills for a person to be able to handle his or her money responsibly and wisely. We talk about the improvement of the financial literacy of a consumer. The educational system of a country plays a crucial role in this process, especially in the case of children and young people. Concretely, the incorporation of financial issues in curricula at all levels in schools and the educational methods that are used within their teaching. The following text is devoted to the introduction of selected teaching methods that are based on the techniques of IBME and are, as we have experienced, eminently suitable for application in the process of improving financial literacy. The specific application of these methods in the teaching of financial issues will be demonstrated in particular examples.

### 4.3.2 A teaching method

A teaching method can be defined as an organised system of the teaching activities of the teacher and the learning activities of pupils or students destined for the achievement of the given educational objectives<sup>27</sup>.

The aim of the teaching methods is to provide students with the respective knowledge and skills in an appropriate way and to enable them to recognise and understand the reality surrounding them<sup>27</sup>.

The teaching methods are closely connected to the content and objectives of a particular phase of the educational process. No universal teaching method exists that is suitable for all educational objectives. On the other hand, it is not generally possible to reduce the effect of a particular method to only one specific topic or subject. In most cases we deal with applications of generally defined methods within the particular instructional situations with concretely fixed educational objectives. This is also the case in financial education.

### 4.3.3 Classification of teaching methods

Various criteria to classify teaching methods can be found in specialised didactic literature. For example, the teaching methods are classified according to

- the logical procedures being applied,
- phases of the instructional process,
- level of the activity and the application of the heuristic techniques (i.e. the use of the activating and constructivist approach to learning<sup>25</sup> within the instructional process.

In this text we are going to follow the classification of the educational methods of Maňák and Švec<sup>27</sup>, which suitably combine the above mentioned approaches. They distinguish over twenty teaching methods that are divided into the three main groups of classical, activating and complex teaching methods, according to the growing complexity of the educational bonds that are created through them. Many methods have their place in financial education but in this article we will focus only on the selected three methods that are, as we have experienced, crucial to the application of the IBME approach to the teaching of financial issues. They are the problem and situation methods belonging to the class of activating methods and the project method which belongs to the class of complex teaching methods.



## 4.3.4 Problem-based teaching method

### 4.3.4.1 Heuristics methods

Heuristic methods are based on the active approach of pupils to the gaining of new knowledge. Compared to traditional lectures the teacher does not disseminate information directly but rather guides pupils to discover and learn new information for themselves. The teacher acts as a facilitator of learning. He or she guides his or her students and helps or advises them if necessary in their search for knowledge. The teacher:

- Asks questions.
- Points out various contradictions and problems.
- Introduces students to interesting cases and situations.

For the successful application of the heuristics methods in education the thorough preparation of a lesson and the professional qualities of the teacher are crucial. The topic and the course of a lesson must be connected to the knowledge and skills that students have already acquired. The objective of the lesson must be clearly stated and must be on a par with the pupils' abilities. The teacher must be so familiarised with the topic and with the abilities of the pupils that he or she is able to steer the course of a lesson to the given objective. When considering the application of heuristics methods a teacher should also bear in mind the time consumption of this method. As with any other, this method is not universal. Some knowledge cannot be acquired through the application of the heuristic method.

### 4.3.4.2 Problem solving

The method of problem solving, the problem-based teaching, is regarded as the most effective and the most carefully developed heuristic method. One of the educators who first applied this method in school was the American psychologist and educator John Dewey<sup>22</sup>.

The leading notion of this educational method is the "problem". Wincenty Okoń<sup>29</sup> understands the "problem" as a theoretical or practical difficulty that a pupil must solve by means of thought and active inquiry.

#### **Example No. 1: "A personal and a family budget. Financial planning."**

The use of the problem method will be presented by means of an outline of a model lesson block aimed at a personal and a family budget.

#### **EDUCATIONAL OBJECTIVE OF THE LESSON BLOCK**

A student should be able to draw up a personal or a family budget. In the case of a budget deficit he or she should know what measures to offer in order to eliminate it. Conversely, in the case of a surplus budget he or she should know how to manage the free financial resources.

#### **PHASES OF THE LESSON BLOCK**

##### **I. Review**

Students are already able to distinguish regular and irregular incomes and expenditures as well as incomes that are fixed, controllable or superfluous. They know how to draw up a personal and a family budget and they are able to determine the type of the budget. They are oriented in the basic financial products that are designed on the one hand for the investment of surplus money and on the other hand for acquiring additional financial resources.

## II. Exposure to the subject matter

The teacher introduces students to the notions “property and undertakings of a household”, “personal financial and real assets”. He or she presents these notions in connection with the drawing up of a family budget and the determination of its type and presents sample solution to the following concrete examples corresponding to this topic.

### INTRODUCTION EXAMPLE 1: *Financial situation of a family*

*Mr. and Mrs. Novák and their 12 years old child live in a flat that is part of their personal property. The actual market price of the flat is of 1,750,000 CZK. To purchase it they used their small savings together with a mortgage credit of 1,400,000 CZK taken out five years ago. The actual amount of their mortgage debt is 1,159,900 CZK. To purchase part of the flat's furnishings to the value of 45,000 CZK they used an installment plan with a pay-back period of 3 years. Their present debt is 23,400 CZK. After subtraction of all expenditures the Novák family has a stable amount of free financial resources of around 17,000 CZK in their current account. Other free financial resources rest in term deposit with a three month period of notice (150,000 CZK) and in a saving account (50,000 CZK). The Novák family has a car with the market value of 200,000 CZK. To buy it they used a consumer credit with a pay-back period of 5 years. The present debt is 187,000 CZK. The remaining family's personal property (jewellery, electronics etc.) has a value of about 150,000 CZK.*

- a) *What is the financial situation of the Novák family? Decide whether they are overextended or whether they would be able to immediately repay all their financial debts.*
- b) *Determine the personal financial and real assets of the Novák family.*

### Solution

We give only brief answers here, leaving the detailed solution to the reader:

- Ad a.** The Novák family would not be indebted if they sold all their property. They would still have about 1,000,000 CZK.
- Ad b.** Personal financial assets: The interest from the money in their accounts adds to the family budget.  
Personal real assets: Flat, furnishing and car.

### INTRODUCTION EXAMPLE 2: *Family budget*

*Mr. Novák is a shift worker at a machine-building plant with a monthly net income of 25,000 CZK and Mrs. Novák is a teacher at a basic school with a monthly net income of 18,000 CZK. Besides their salaries they get interest of 240 CZK from their savings account every month. They have got no other income.*

*The Novák family has the following monthly expenses:*

*Cost of housing (repair fund, advance on electricity, gas and water): 6,000 CZK; food: 10,000 CZK; drug-store: 850 CZK; car expenses: 1,000 CZK; telephone and Internet: 1,800 CZK; transport to work and school: 800 CZK; entertainment and culture: 1,500 CZK; clothes: 2,000 CZK; mortgage credit installment: 8,932 CZK; consumer credit installment: 7,609 CZK, installment to a consumer finance provider: 1,800 CZK.*

*Determine the type of budget of the Novák family. In the case of a deficit budget suggest measures to balance it. In the case of a balanced budget suggest measures to change it into a surplus budget. In the case of surplus budget decide on an investment for the free financial resources.*

## Solution

The teacher draws up the Novák family monthly budget together with students. They record it into the following table (all amounts are given in CZK):

Net incomes		Expenses	
Mr. Novák	25,000	Housing	6,000
Mrs. Novák	18,000	Food	10,000
Interest	240	Drugstore	850
		Car expenses	1,000
		Telephone, Internet	1,800
		Entertainment and culture	1,500
		Transport	800
		Clothes	2,000
		Mortgage credit installment	8,932
		Consumer credit installment	7,609
		Installment to a consumer finance provider	1,800
Total	43,240 CZK	Total	42,291 CZK

Then they can collectively arrive at the following conclusion: The Novák family manages its finance with a surplus budget. The surplus amounts to  $43,240 \text{ CZK} - 42,291 \text{ CZK} = 949 \text{ CZK}$ . The surplus of 949 CZK per month looks rather small but the annual total surplus of 11,388 CZK represents a respectable amount that can be used, for example, to cover the family's domestic holiday. For this reason we would advise the Novák family to take advantage of a savings account, preferably linked to their current account, to accumulate and also slightly increase the value of their surplus money.

### III. Problem solving

The teacher assigns the following problems:

#### PROBLEM 1: *Financial planning*

*Mr. and Mrs. Novák supposed that their child, now aged 12, will enter university in about seven years' time. They estimate the monthly study expenses at about 10,000 CZK. Moreover they expect the introduction of a school fee in the amount of 20,000 CZK per year.*

*Decide whether the Novák family will have sufficient financial resources to cover the child's university study? Use examples 1 and 2 for the assignment.*

## Solution

The Novák's family budget is currently slightly surplus but the annual surplus would not suffice to save enough money to cover the university study, in spite of having seven years to save (the annual surplus amounts to  $12 \cdot 949 = 11,388 \text{ CZK}$ ). The expenses would be approximately  $5 \cdot 120,000 \text{ CZK} = 600,000 \text{ CZK}$  (presuming 5 years of study, each study year having 10 months).

The solution of the problem can be split into the following four partial problems:

**PROBLEM 1 – Partial problem 1: Search for budget reserves**

*Find reserves in the Novák's family budget. Suggest possible ways as to how they can attain sufficient free financial resources.*

The task of finding reserves in the budget is discussed with students. This discussion can produce various suggestions, with the following being the most likely:

- a. Reduction of the monthly expenses (telephone, clothes, entertainment, ...).
- b. More effective ways of increasing the value of financial assets (savings account, term deposit).
- c. Counting on the diminishing of the family's financial undertakings in the future.
- d. Increasing of the family's incomes (e.g. change of job, subsidiary income, work advancement etc.).

Let us inspect the efficiencies of these measures (figures given in the item "a" arose from the students' discussion).

**Ad a.** The monthly expenses could maximally be reduced by approximately 2,300 CZK as follows: telephone and Internet from 1,800 CZK to 1,300 CZK, car expenses from 1,000 CZK to 700 CZK, entertainment from 1,500 CZK to 1,000 CZK, clothes from 2,000 CZK to 1,500 CZK and food from 10,000 CZK to 9,500 CZK. Such reductions would bring savings of 193,200 CZK over seven years. This amount would cover two years of university study.

**Ad b.** Now, the interest from the money in the Nováks' saving account and term deposit would bring them 20,160 CZK over seven years. This is not very much. They could try to invest their free financial assets more effectively in some long-term saving. They should respect the recommendation to keep a financial reserve of at least three monthly expenditures accessible. For the Novák family this is around  $3 \cdot 42,291 \text{ CZK} = 126,873 \text{ CZK}$ . Therefore they could invest only about 100,000 CZK (rounded result of the difference between 217,000 CZK and 126,873 CZK, where 217,000 CZK is the total of all their financial assets) in the long-term. Unfortunately it is not feasible to attain a sixfold bigger appreciation of this amount.

**Ad c.** Detailed inspection of the structure of the family's financial undertakings will reveal the following facts: the mortgage credit will be paid back over 15 years, the consumer credit over 2 years and 4 months and the installments to a consumer finance provider will be paid over 13 months. Because the Nováks' children will enter university in about seven years' time they should count on the surpluses appearing after the repayment of the consumer credit and the installment plan. These will bring  $5 \cdot 12 \cdot 7,609 \text{ CZK} = 456,540 \text{ CZK}$  and  $6 \cdot 12 \cdot 1,800 \text{ CZK} = 129,600 \text{ CZK}$ , respectively. Then the total surplus of 586,140 CZK will cover almost all study costs. Moreover if the Nováks continue saving in this way during their child's studies they will get other funds in the amount of  $5 \cdot 12 \cdot 7,609 \text{ CZK} + 5 \cdot 12 \cdot 1,800 \text{ CZK} = 456,540 \text{ CZK} + 108,000 \text{ CZK} = 564,540 \text{ CZK}$ .

**Ad d.** It is almost impossible to find a better paid job owing to the current state of the labor market. Also the possibility of getting a well paid subsidiary job is almost zero. Advancements in jobs are unrealistic because of Mr. and Mrs. Novák's professions.

Conclusion: The measure "c" offers an optimum way of finding financial reserves by counting on finishing some of the financial undertakings before the start of the Novák child's studies.

A wise person cares about increasing the value of his or her financial reserves. Students are already informed about the basic financial products that are designed for the investment of surplus money. Now they should consider their use to increase the value of the Nováks' financial reserve.

**PROBLEM 1 – Partial problem 2: *Increasing the value of financial reserves***

*Consider the use of basic financial products that are designed for the investment of surplus money to increase the value of the Nováks' financial reserve which was recognised during the preceding problem solving.*

In the following table we can see various students' suggestions for increasing the Nováks' financial reserve.

Financial product	Advantages	Disadvantages
Building society account	<ul style="list-style-type: none"> <li>▪ Full insurance of an account up to a deposit of 100,000 EUR.</li> <li>▪ State support of up to 2,000 CZK per year.</li> <li>▪ The annual interest rate is between 2 % and 2.5 % (including the state support).</li> <li>▪ Savings are not tied to any specific purpose, i.e. building.</li> </ul>	<ul style="list-style-type: none"> <li>▪ Deposited money is inaccessible for 6 years if we want to get the state support.</li> <li>▪ Interest from both deposit and state support is taxed at 15 %.</li> <li>▪ It is not the most effective investment of amounts exceeding 300,000 CZK.</li> </ul>
Unit trust	<ul style="list-style-type: none"> <li>▪ Yields are not taxed if we hold the shares for longer than 6 months.</li> <li>▪ Acceptable liquidity.</li> <li>▪ Provide the diversification of risk.</li> <li>▪ Professional management.</li> <li>▪ Rate of return between 3 % and 9 %.</li> </ul>	<ul style="list-style-type: none"> <li>▪ No insurance of the deposit.</li> <li>▪ Yield usually oscillates. Instead of earning we can lose.</li> <li>▪ Various kinds of fees decrease the yield.</li> </ul>
Securities	<ul style="list-style-type: none"> <li>▪ Yields are not taxed if we hold the shares for longer than 6 months.</li> <li>▪ Higher yields are possible.</li> </ul>	<ul style="list-style-type: none"> <li>▪ No insurance of the deposit.</li> <li>▪ Considerable loss is possible.</li> <li>▪ No diversification of risk.</li> </ul>
Term deposit, savings account	<ul style="list-style-type: none"> <li>▪ Full insurance of an account up to a deposit of 100,000 EUR.</li> <li>▪ Money in short-term deposits or savings accounts is readily accessible.</li> <li>▪ The annual interest rate between 1 % and 5 %.</li> </ul>	<ul style="list-style-type: none"> <li>▪ Interest is taxed at 15 %.</li> <li>▪ Money in medium-term and long-term deposits is inaccessible for several years (from 2 to 5 years).</li> </ul>

**Conclusion:** The Nováks' choice depends on their preferences and their inclination to risk. If they are 'conservative investors' they will probably choose between the unit trust, term deposit and the savings account. If they are so called 'aggressive investors' they will supposedly invest in the securities.

### **PROBLEM 1 – Partial problem 3: *Effect of inflation and financial market changes on savings***

*Discuss the impact of inflation on savings and also possible changes in the terms of use of the considered financial products.*

Having solved the problem of financial means students should turn their attention to the impact of inflation on savings and also to possible changes in the terms of use of the considered financial products. For example, the government is discussing the possibility of tying state support for saving with a building society to be used for building purposes only.

### **PROBLEM 1 – Partial problem 4: *Securing for the future***

*The Nováks have not considered any means of securing their financial future for their old age. Discuss the pension schemes offered in our country and what possibilities there are for a supplemental pension insurance and a life insurance.*

### **HOMEWORK – *Financial plan***

*Suppose that the Nováks have two children aged 9 and 12 years. Both would like to enter university. The expected monthly study expenses will be about 10,000 CZK plus a school fee of 20,000 CZK per year. Draw up a financial plan for the Nováks for the next 15 years. Use previous problems and their solutions for the assignment.*

#### **4.3.5 Situation method**

The subject matter of a situation method is the solution of a problem situation that reflects some real situation with an unambiguous resolution. Students learn to manage real problems thoughtfully and without difficulty through this method. Compared to the problem-solving method, which does not reflect the context of a problem, the situation method is focused on the situation context of a problem. The situation method brings practical real-world problems to school and strives for their complete solution. Students learn to brainstorm, argue and defend their opinions through this method.

Not even this method can avoid necessary simplification and reduction of a situation before its presentation in the classroom. Moreover the success of the situation method is sensitive to the initial conditions of its application. Students must have knowledge and experience adequate to the given situation.

Phases of the situation method application <sup>27</sup>:

1. The topic selection. It must be in accordance with the objectives of the tuition and must correspond to the state of preparation of the students.
2. Getting to know materials. Pupils or students should have access to important facts, which are essential for the solution. They can get the necessary materials themselves.
3. Study the given case (situation). The teacher should introduce students to the given situation, define the objectives and provide students with advices and directions.
4. Suggestions of solutions, discussion. Pupils or students present their opinions, suggestions and outlines. The teacher presents them with the reality.

Various types of situation methods are distinguished in specialised literature. For example in <sup>27</sup> the following four types of the situation method are mentioned: method of a situation analysis, method of a conflict situation solution, method of an incident and the dynamic situation method. Although each of these methods has its place in financial education we will illustrate the situation method only through the method of a situation analysis.

### Example No. 2: “Credit card – A typical way to a debt trap”

A credit card itself can be a very effective and helpful payment tool. But we must use it wisely and with full knowledge of all its pros and cons. This project is inspired by the story of a real consumer.

We will apply the five steps methodical procedure recommended by Maňák and Švec <sup>27</sup>:

#### I. Presentation of the given situation

The teacher introduces students to the situation through the following assignment:

#### INTRODUCTION TO THE SITUATION

*A year ago we took advantage of an installment credit company service to buy a mobile phone to the value of 10,500 CZK. The company had just announced the action which offered credit with a zero interest. It means that we immediately paid 10 % of the phone's value (1,050 CZK) as an advance payment and then we paid 10 % of the phone's value, i.e. 1,050 CZK, every month for the next nine months. We paid nothing extra. The APR (annual percentage rate) was zero percent.*

*The contract was arranged and signed immediately on site because we had two identification documents, identity card and driving licence, with us.*

*After the payment of all installments we mistakenly assumed that the contract was closed. The company got our personal data and used it to continue in its business. In a couple of weeks we got the following letter from the installment company that provided the loan enclosing a free use credit card, called the Silver Card.*

**APPROVED FOR LIFE**

Dear Mr./Ms. XY,

Let me congratulate you. Thanks to your reliable payments we have approved the possibility of a hire purchase plan according to your needs.

Hereafter you can take out

**any kind of installment buying for up to 40,000 CZK in total**

already with a monthly installment rate from **600 CZK\***.

With the Silver Card, wherein we have deposited money for you, you can buy everything that you need. Without any other paperwork! You simply choose your favorite product and pay for it with the card.

What to do?

Simply activate your card by phone:

- Prepare your personal identification number and the number of your Silver Card 1111 1111 1111 (card is stuck on the right bottom side of this letter).

- Call the number 2222 2222 2222, where you will be guided through the simple activation process.

In the following days you will get the PIN code to protect your card.

Variations of installments and detailed information on the card can be found in the enclosed brochure.

Yours sincerely,

Phil Anthropist  
director of the client relations center

\* the installment rate amounts to 4 % of the loan framework you will have chosen. But you can of course pay back more or you can pay the remaining amount altogether.

*The Silver credit card was enclosed together with the 'Card holder handbook', a brochure that contained detailed information as to the use of the card.*

## II. Obtaining other information

Students have both materials provided by the installment company: the covering letter and the 'Card holder handbook'. They have been introduced to the problem of consumer credit and they should understand all notions given in the brochure. They can also use the internet to find information or to refresh their knowledge. Students work in small groups in the computer lab at this stage.



### III. Solution of the given situation

#### TASK 1 – A notebook purchase

You have decided to buy a notebook for 20,000 CZK using the offered Silver Card. How much will you pay for it finally?

Read the letter from the credit card company again. Do you have enough information to know how much the notebook will cost? Does the slogan "... any kind of installment buying for up to 40,000 CZK in total already with a monthly installment rate from 600 CZK" provide you with sufficient information to compute the final price of the notebook? What extra information do you need to know?

Working with the real materials students will quickly learn how to understand such slogans. They will catch on to the importance of such words as "up to" and "from" and also the really essential importance of the underline notes, which are linked by asterisk and mostly typed in small font-size. For example in the case of the above letter the underline note reveals us the relation between the minimum amount of an installment and the loan framework (e.g. to the loan framework of 40,000 CZK corresponds the minimum installment 1,600 CZK).

Detailed reading through the 'Card holder handbook' should direct students to extra information that is necessary to derive the real final price of the notebook.

We need to know the amount of the administration fees (35 CZK per month) and the annual interest rate of the loan.

A student faces another advertising trick: There is only a monthly interest rate of 2.22 % mentioned in the brochure. What is the annual percentage rate?

Finally, students will create an installment plan for the loan most convenient for the notebook purchase.

#### TASK 2 – Installment plan

Create your own installment plan for the loan. Determine the total amount of the loan debt. Use the 'Card holder handbook' to determine the most convenient values of the following parameters:

- loan framework,
- amount of loan,
- interest rate,
- amount of installment.

Find out the influence of the loan framework amount on the final price of the notebook. Create an installment plan with respect to the different loan framework.

Use a spreadsheet or do it by hand. You can follow the next pattern of a spreadsheet application.

	A	B	C	D	E
1	Month	Amount	Installment	Fee	Balance
2	0				20000
3	1	=E2*(1,0222)	1800	35	=E3-C3
4	2	=E3*(1,0222)	1800	35	=E4-C4
5	3	=E4*(1,0222)	1800	35	=E5-C5
6	4	=E5*(1,0222)	1800	35	=E6-C6

Repeat the computation one month (line) after the other until you get zero or a negative balance.

Students create several installment plans (to buy the notebook for 20,000 CZK) with respect to different initial conditions (loan framework and amount of an installment). Their comparison is really informative. For example the installment plan in Fig. 9, corresponding to the loan framework of 40,000 CZK with an installment of 1,600 CZK, offers an acceptable total loan amount of 24,213 CZK.

	A	B	C	D	E
1	Month	Amount	Installment	Fee	Balance
2	0				20000,00
3	1	20444,00	1600	36	18844,00
4	2	19262,34	1600	36	17662,34
5	3	18054,44	1600	36	16454,44
6	4	16819,73	1600	36	15219,73
7	5	15567,61	1600	36	13967,61
8	6	14297,47	1600	36	12697,47
9	7	12948,68	1600	36	11348,68
10	8	11600,62	1600	36	10000,62
11	9	10222,64	1600	36	8622,64
12	10	8814,06	1600	36	7214,06
13	11	7374,21	1600	36	5774,21
14	12	5902,40	1600	36	4302,40
15	13	4397,91	1600	36	2797,91
16	14	2860,03	1600	36	1260,03
17	15	1288,00	1288,00	36	0,00
18			23688,00	525	
19					
20		<b>TOTAL:</b>	<b>24213,88</b>		

Fig. 9: Installment plan

Compared to the plan corresponding to the loan framework of 20,000 CZK with an installment of 800 CZK which arrives at the total loan amount of 30,796 CZK.

#### IV. Analysis of possible variants. Discussion.

Other possibilities to obtain the necessary financial means should be also mentioned. The possible financial products should be compared and the best one should be selected.

#### V. Evaluation of results

At the end of the lesson students should be able to describe the function of a credit card, to present its pros and cons and to compare it to other similar financial products. They should be able to recognise aggressive and false advertising of financial services provided by both bank and non-bank companies.

They could formulate a conclusion similar to this one: A credit card is like fire – a good servant but a bad master. A credit card itself can be a very effective and helpful payment tool. But we must use it wisely and with full knowledge of all its pros and cons (an interest-free period, reduced interest rate, good payment discipline). The biggest danger of credit cards is hidden in their high (double-digit) annual interest rates and the possibility to multiply credits on them.

### 4.3.6 Project method

Project teaching is a structured system of activities for the teacher and his or her pupils or students that are directed toward the given objectives, educational processes and the concept behind the project. The dominant role within these activities is played by students, with the teacher mainly in the position of an advisor. The complexity of the project method requires the application of various partial teaching methods and forms of work<sup>26</sup>.

The project teaching method has many features in common with the problem solving method but generally it works with more complex problems. Its educational aims and objectives have a wider practical range. In most cases it touches on more subjects. The project method allows the application of various organisational charts (working in groups, individual assignments, a combination of individual and group work).

### Example No. 3: “Educational project - Find the most advantageous way to obtain the financial means to purchase what you desire most”

This project covers the topic *consumer loans and their use to purchase consumer goods, relation between the interest rate and the annual percentage rate (APR)* that is prescribed in the Czech curriculum document <sup>28</sup> for secondary school education. It is a short-term project which takes 3 or 4 lessons plus several hours of students' individual work outside the school. Students from one class or more parallel classes work in groups each having its own specific task:

#### **TASK 1: Obtaining the financial means**

*Find the most advantageous way to obtain the financial means to purchase:*

*Group No. 1: mobile phone to the value of 13,500 CZK.*

*Group No. 2: computer to the value of 23,500 CZK.*

*Group No. 3: car to the value of 350,000 CZK.*

#### **I. Setting of objectives**

Main objective of the project: To gain the knowledge of all advantages and disadvantages of the use of consumer loans to purchase consumer goods.

Partial objectives: To gain the ability to choose a consumer credit that best fits our personal needs and to be able to defend this choice. To understand the difference between the interest rate and the annual percentage rate (APR).

#### **II. Formulation of the solving plan**

Particular steps of the solution to the task are formulated within the brainstorming:

1. Find out what kinds of loans are intended for the consumer goods purchase.
2. Find out what institution can provide us with a consumer loan.
3. Find out what terms of use are required by each of the providers. If possible check their credibility on site.
4. Compare all recognised offers. Evaluate their advantages and disadvantages.
5. Select a loan product that would best correspond to our requirements.
6. Process the acquired information, present it and justify the choice of the best loan.

#### **III. Realisation of the plan**

In the first three lessons students use the Internet and other resources (bank leaflets, textbooks) to find out the following information:

- Types of loans:
  - short-term (up to 1 year) – current account, credit card
  - middle-term (1 – 5 years) – consumer credits, installment plan, leasing
  - long-term (5 and more years) – American mortgage
- Basic characteristics of these types of loan.

- Institutions that provide consumer loans:
  - Banks (current account, credit card, consumer credit, American mortgage)
  - Installment companies (credit cards, installment plan, cash loan)
  - Leasing companies (leasing, consumer credits, installment plan, credit card)
  - Other non-bank companies that offer cash loans
- Terms of use

Students should personally visit or at least phone the concerned companies and check the information provided by them on the Internet and in their advertising. In some cases they will find that some important information is not noticeable at first glance.

#### IV. Assessment

At the end of the project students will prepare a public presentation and rational justification of their choice. They will present it in front of their schoolmates or, even better, in front of the whole school with their parents as guests.

Students participating in the project are brought closer to practical finance and gain important knowledge about consumer loans.

Another project focused on the consumer loan, this time intended for the buying of a tumble dryer, is presented in detail by Hašek and Petrášková <sup>24</sup>.

#### Conclusion

In this article the authors laid out their experience in the application to financial education selected teaching methods that are based on the techniques of inquiry-based mathematics education (IBME). They presented three particular examples related to their practice as teacher educators and consultants. Other authors' ideas dealing with financial education at basic and secondary schools, together with particular examples are also presented by Hašek and Petrášková <sup>23, 24, 30, 31</sup>.

## 4.4 IBME in primary schools in Bulgaria: Some examples of dynamic scenarios and their implementation in a class setting

*Toni Chehlarova*

### 4.4.1 Counting rectangles

One of the fundamental goals of the mathematics education in the primary school is to build skills for identification of the figures being studied. When the specific figures intersect the problem of identification is more complicated. Here are some examples.

**Example 1:**

Count the number of:

- a) squares;
- b) rectangles.

Use the auxiliary green figures. Use the slider for another example. Create your own problem.



Fig. 10

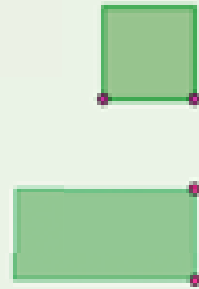
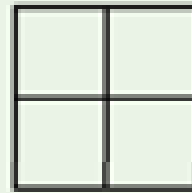

Only a few of the pupils can solve the problem on their own; but after the first example is discussed with the class the number of those who can deal with more complex problems of this kind is significantly larger. The children observe the figures and try to reach a complete solution. This is the reason that problems of this kind are typically used for identification of young mathematical talents, but it could also enhance the cognitive development of all students.

In Example 1 the key point in task a) is to see the “big” square. With a dynamic model the children have a *dynamic square* and a *dynamic rectangle* as auxiliary tools, i.e. they could move them and change their size, a property which is especially useful for the next examples of figures.

In task b) the students have to figure out that the square is also a rectangle and therefore the solutions of a) are also solutions of b).

The solution could be presented in various manners, e.g.: four 1x1 squares, one 2x2 square, two 2x1 rectangles, and two 1x2 rectangles (Fig. 11).

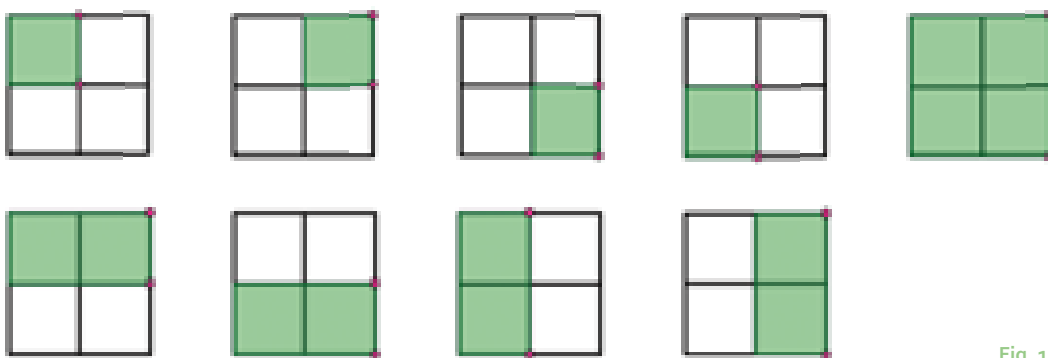

Fig. 11

Another way is to denote the unite squares by numbers, letters, or both numbers and letters as in chess. If we use numbers the description of the solution as illustrated in Fig. 11 would be as follows: 1, 2, 4, 3, 1234, 12, 34, 13, 24. If the chess tradition is used, then the same solution would be presented as: a2; b2; b1; a1; a1,a2,b1,b2; a2,b2; a1,b1; a1,a2; b1,b2.

An additional moral of considering this problem is to follow a strategy facilitating the exhaustion of all cases. In our case we have counted first the squares, starting with the unit ones, then with the  $2 \times 2$  ones. Next we count the rectangles which are not squares, by starting first with the  $2 \times 1$  ones, and then – the  $1 \times 2$  ones.

Another approach would be to start the counting with a unit square and exhausting all its appearances as a part of rectangles. Then – to continue with the next unit while neglecting the rectangles containing already used squares (thought of as *crossed out*).

The next examples of the problem deal with augmenting the number of the unit squares, but our experience shows that it is sufficient to count the rectangles in a  $3 \times 3$  square and only when necessary to go back to simpler cases.

The next group of problems is suitable for the mathematically gifted students, viz. to look for patterns in the number of different groups of rectangles when considering sequences of figures as the ones below (Fig 12):

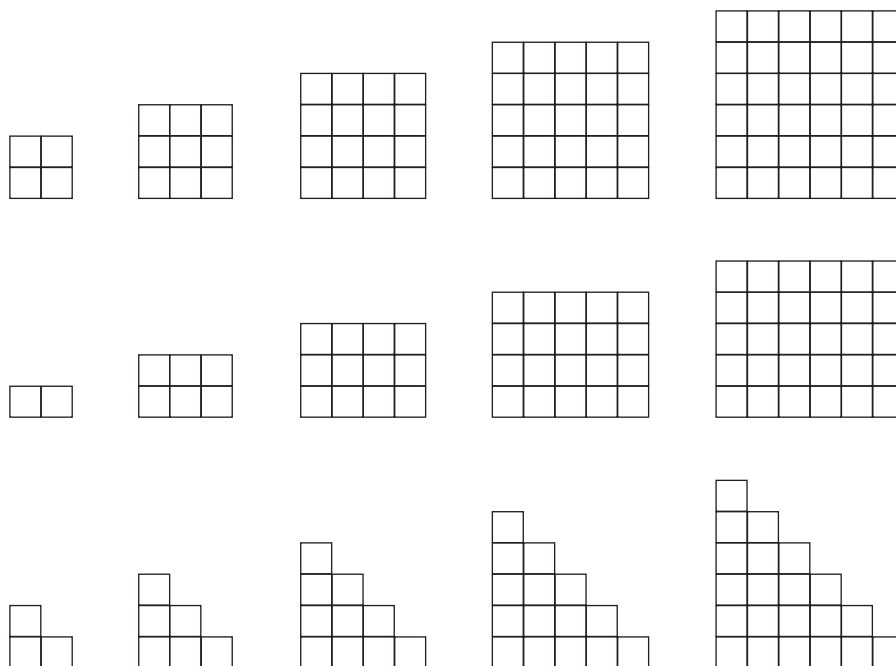

Fig. 12

**Example 2:**

Count the rectangles which are half purple.  
Move the slider for another example.



Fig. 13

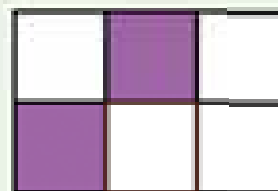

The virtual dynamic environment provides a natural way for demonstrating the solutions by means of the auxiliary green figure:

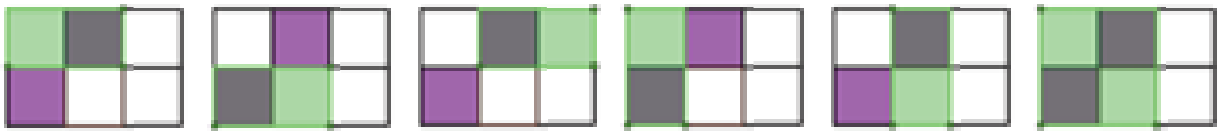
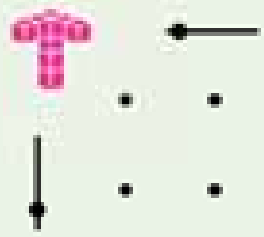

Fig. 14

A possible preliminary step is to figure out that if we are looking for half purple figures it is sufficient to consider the rectangles with an even number of unit squares.

**Example 3:**

*Count the squares with vertices being some of the dots:*



*Get another example by means of the slider.*

Fig. 15

A new idea here is the square with a diagonal of 2 units length, and other “rotated” squares as shown in the figure below (Fig. 16).

Fig. 16

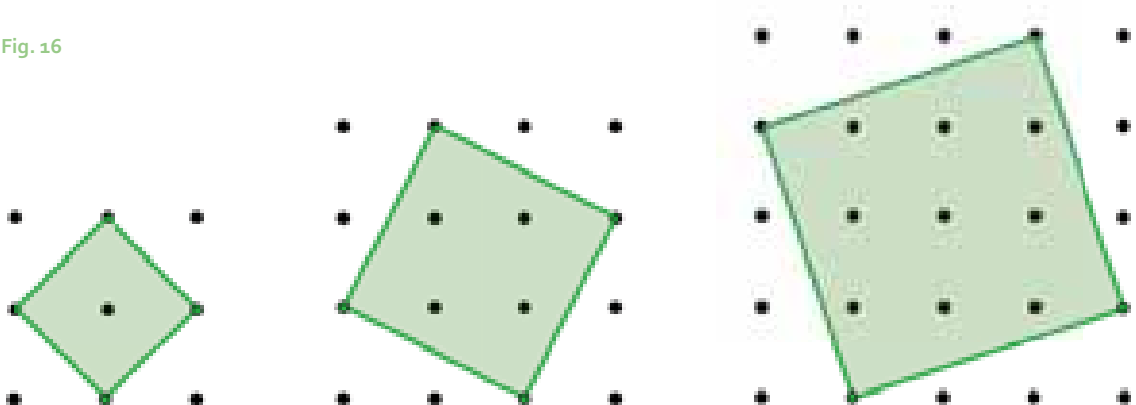

One could solve the problem in several different ways. Making use of the previous problem we could consider here only the “rotated” segments. It is easy to reach these squares by means of the auxiliary dynamic square.

Let us remind that according to the current curriculum of the Bulgarian school system it is after the 7<sup>th</sup> grade when the students will prove their results. Here they are expected to develop their intuition and imagination. Of course, they could argue their findings by using the diagonals of congruent rectangles but this would be again based on their intuitive understanding of congruence by imposing one object on another.

Some puzzles of the ancient times enjoy their being widely spread today thanks to the simplicity of the formulation and the insight needed for solving them.

Such problems could be considered as backbones of ideas, methods, and theories in mathematics whose introduction in the education would reveal the real nature of mathematics as a science.

**Example 4:**

*Move two matches so as to get 4 squares.*

*How many solutions did you find?*

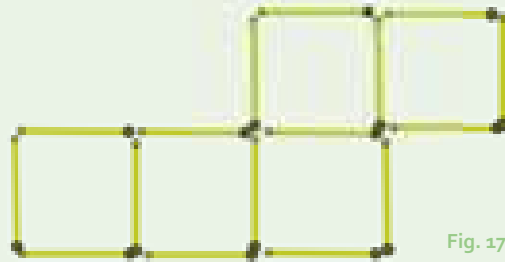

Fig. 17

It is important to introduce certain order in the reasoning according to a specific feature, to apply various methods, to shorten the number of checks, etc. in order to find all the solutions for a reasonable time.

Some typical mistakes we have come across for students were to neglect the whole figure when counting. Similarly, when solving the problem *Count the rectangles whose colored part is more than the half* the students had not included the fully colored figures.

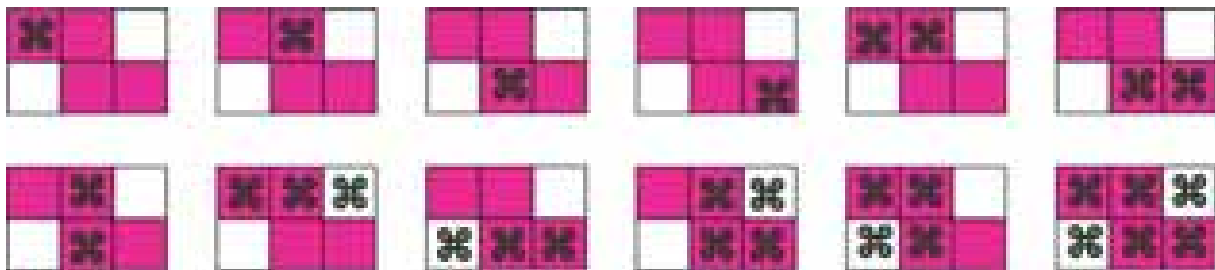

Fig. 18

A common feature of considered problems is that they provide a good ground for accumulating basic ideas and methods in mathematics (e.g. symmetry, parity, analogy) enabling to reduce the time for reasoning. Furthermore, when solving them the students acquire skills of observing, concentrating on a specific object, describing and representing their solutions in various ways – all these being crucial features in the inquiry based learning.

### 4.4.2 Explorations with a virtual analogue clock

As early as the beginning of the 20th century research has shown that children’s concept of time is complex and therefore difficult to teach<sup>33</sup>. This is the reason that clock reading is considered a key time-related subject that plays a role in nearly every grade of primary school.

As discussed in<sup>34</sup> clock reading builds upon mathematical, visuospatial and linguistic sub-competences and requires the development of cognitive-conceptual representations. Furthermore, clock reading is discussed



as skill in primary education that mirrors the complexity of time conceptions in general, and thus should be addressed explicitly, and taught in a systematic way.

With this idea in mind we developed a dynamic learning environment in support of the time telling published within the Fibonacci resources of the Bulgarian team<sup>35</sup>.

The first who reported of having used the virtual models to teach the children how to tell the time by means of the “clock with hands” were some parents and grandparents.

Additional advantages to this obvious use though include the development of the space intelligence, intuition, resourcefulness and quickness of mind which we would like to discuss below.

The dynamic models are developed with precision of an hour, half an hour, 15 min, 5 min, 1 min., and 1 sec.

Here are some examples of problems from the Dynamic Clock scenario:

**Example 1:**

*Look at the clock and tell the time.*

*Hide the answer and move the slider for another problem.*



Fig. 19

The emphasis is on the fact that with the analogue clocks the a.m. (before midday) and the p.m. (after midday) periods are depicted the same way. Therefore the answer which appears after a click on the check box contains the two options. It is appropriate to discuss with the students various ways of reading the time depending on the specific cultures.

For some students this might be the first meeting with a Geogebra-based dynamic environment. If needed the work with the slider and the check box is explained. The proposed applets could be used for self-evaluation as well as for a team work or a competition.

The next problems deal with fixing the hour- and the minute hand so as to match a given time.

**Example 2:**

*Move the red hands so that the clock shows 13:15.*

*Hide the answer and move the slider for another example.*

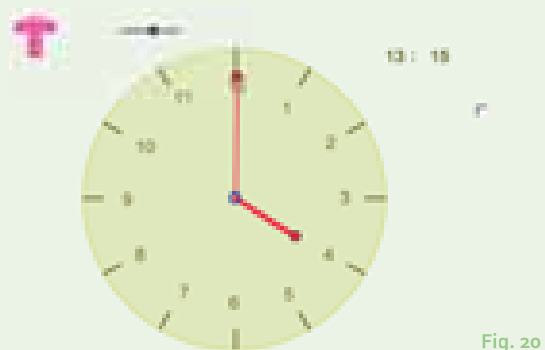

Fig. 20

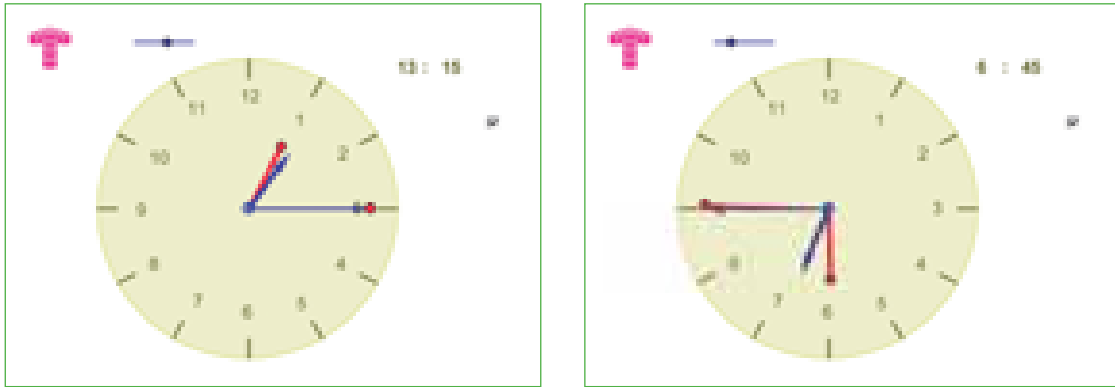

Fig.21 a+b: Typical mistakes of the students (the red hands).

Let us note that we do not expect the young children to calculate the angle of rotation, but to give just an approximate position of the hand.

The next problems could be solved by means of calculations or visually – the children should be able to use both methods.

**Example 3:**

- a. It is now 7 h 30 min. In how many minutes will the time be 8 h 45 min?
- b. It is now 14 h 15 min. How many minutes ago was it 12 h 30 min?
- c. It is now 8 h 45 min. In what time it will be 12 h 30 min?

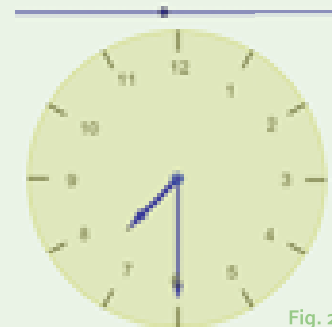

Fig. 22

Some problems deal with a clock face lacking the digits of some hours (as it is sometimes the case in reality):

**Example 4:**

What is the time on this clock?

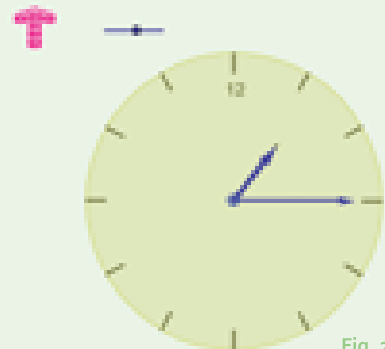

Fig. 23

The virtual clocks are suitable for solving (or checking the solution of) problems of the following kind:

**Example 5:**

5.1 What angle (in degrees) will the minute hand describe in:

- a) 15 min   b) 30 min   c) 5 min   d) 20 min ?

5.2 What angle (in degrees) will the minute hand describe in:

- a) 3 hours   b) 1 hour   c) 5 hours   d) 30 min ?

5.3 In how many minutes will the minute hand describe:

- a)  $60^\circ$    b)  $15^\circ$    c)  $90^\circ$    d)  $6^\circ$  ?

5.4 In how many hours will the hour hand describe:

- a)  $30^\circ$    b)  $120^\circ$    c)  $180^\circ$    d)  $15^\circ$  ?

5.5 The minute hand describes for 17 min an angle which is:

- a) right   b) acute   c) obtuse .

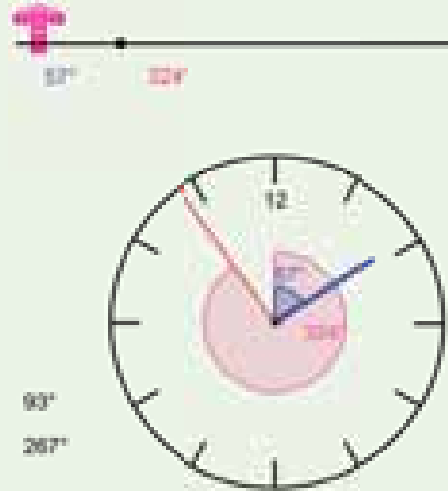

Fig. 24: An auxiliary tool

A set of problems with maladjusted clocks are presented in <sup>36</sup> and some of them could be found in <sup>37</sup>. Here are some examples.

**Example 6:**

6.1 The first clock is forward by 5 min. How many minutes behind is the second clock?

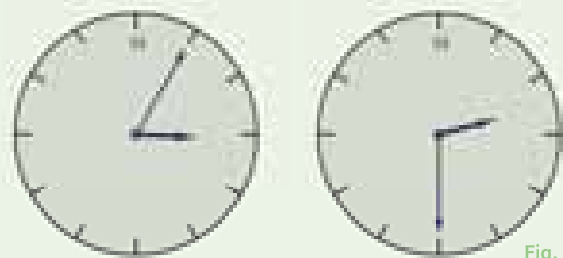

Fig. 25

6.2 The two clocks below are working normally but are not adjusted properly. The first one is forward by 10 min. What will be the right time when the second one shows 5 h?

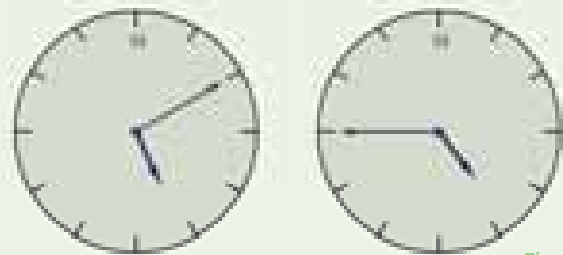

Fig. 26

By solving such problems the students are prepared for the next step – to figure out how many times in twenty-four hours the hour- and the minute hands are perpendicular.

As seen of the presented scenario fragments a variety of mathematical knowledge and skills is required so that the students are able to tell the time: (i) a number sense and the ability to count; (ii) a basic understanding of fractions to appreciate the division of the clock face; (iii) adding and subtracting skills for measuring time-intervals.

In addition, various mathematics problems could be formulated in the context of the time telling that are both intriguing and close to the students' reality.

## 4.5 IBME in the secondary school: Overview and examples in a Bulgarian context

*Toni Chehlarova, Evgenia Sendova*

### 4.5.1 Overview – the lessons from the first IBME & ICT attempts 25 years ago

The development of digital technologies presents mathematics educators with real challenges in spite of the long traditions of teaching mathematics. One of the major problems is how to create a class culture integrating these technologies so that the students could behave like working mathematicians, i.e. play with mathematical ideas and communicate their findings. To create such a class culture by designing and developing computer environments of exploratory type, and then experiment with new principles of teaching has been the goal of a long-term research in Bulgaria dating from the early 80's.

The first attempts are related with the Research Group on Education (RGE) – having carried out an educational experiment launched by the Bulgarian Academy of Sciences and the Ministry of Education in 1979 <sup>38, 39</sup>. It comprised 29 pilot schools (2 % of the Bulgarian K-12 schools) and its main goal was to develop a new curriculum designed to make the use of computers one of its natural components. The guiding principles of RGE were *learning by doing*, *guided discovery*, and *integrated school subjects*. The experiment ran for 12 years.

It was in the frames of the RGE experiment that a team mentored by Bojidar Sendov comprising graduate students from the Faculty of Mathematics and Informatics at Sofia University (with Rossen Filimonov and Georgi Georgiev as principal developers) had been developing and experimenting since 1986 with the *Plane Geometry System* (or *Geomland*). This system represents a *mathematical laboratory* <sup>40, 41</sup> enabling pupils to construct and experiment with Euclidean objects, to investigate their properties, to formulate and verify conjectures, i.e. to *discover* mathematics. *Geomland* proved to be an appropriate environment for materialising the abstract mathematical concepts. Bridging the gap between the real world and the abstract world of mathematics by providing the flexibility of experimenting with materialised abstraction helped the learners move fluently in both directions along the path, as needed.

Our experience in integrating *Geomland* into the mathematics classes <sup>42 – 47</sup> has shown that it is possible to adopt the style of “discovery learning” – a style tuned to the natural wishes of pupils. They got the feeling of becoming contributors to the establishment of mathematical facts. Furthermore, they mastered their mathematical language <sup>48</sup>, since a precise formulation was necessary to make their definitions and solutions *workable*. With clever guidance, pupils looked for patterns, formulated hypotheses, posed problems and were highly motivated to *prove their own* theorems.

The teachers involved in the pilot RGE experiments got convinced that to teach guessing and conjecturing is vital for conveying the real spirit of mathematics in a school setting. Furthermore, some of them gained a sufficient self-confidence to adopt the role of researchers – they created whole classes of mathematical problems that were new to the existing curriculum. Before proving their hypotheses they verified them with *Geomland* and investigated various extensions of the initial problems.

The positive results of the RGE experiment were later transferred to the university level – since 1989 the traditional core of mathematics disciplines taught at the Faculty of Mathematics and Informatics at Sofia University has been enriched by the course *Teaching Mathematics in a Laboratory Type Environment* <sup>49</sup>.

The mathematics teachers-to-be experienced the real feeling of “doing mathematics”. After years of studying and reproducing very sophisticated mathematical facts they were put into situations where they could say: “Look at my construction!”, “Can you prove my theorem?”, “Look at what I got!” Thus, we expected that such a spirit of discovery would be transferred to their pupils.

Spreading this positive experience on a broader scale turned out to be very difficult at the time for various reasons – both economic and political. However, even with these isolated experiments the lessons learned were valuable – **the teachers’ creativity can be enhanced when provided with an appropriate environment.**

With the advent of powerful modern computers and specially designed educational software for mathematical experiments a way was opened for the inquiry-based learning in many European countries <sup>50</sup>.

The development and the dissemination of *dynamic scenarios* based on dynamic software in which various experiments with mathematical objects can be performed is a focal point in the *Fibonacci* project in a Bulgarian context <sup>51–53</sup>.

What follows is an excerpt of *Fibonacci* dynamic scenarios and their implementations in a class setting. The focus is again on putting the learners in the role of investigators who are expected to explore the dynamic constructions, to formulate conjectures and possibly – to prove them as theorems of their own.

## 4.5.2 Best practices in designing dynamic scenarios and implementing them in Bulgarian Fibonacci schools

### 4.5.2.1 Experiments with compositions of geometric congruencies

The topic of geometric congruencies (translation, rotation and reflection) is an element of the compulsory mathematics education and is taught in the 8<sup>th</sup> grade of the Bulgarian schools. An inquiry based approach of learning this topic by experiments with dynamic constructions is presented in <sup>54</sup> as part of the resources of the Bulgarian site of the *Fibonacci* project. This approach allows to introduce (in the elective classes) compositions of congruencies and to emphasise on some group properties of these transformations <sup>55</sup>.

The notion of a *composition of two congruencies*  $E_1$  and  $E_2$  is introduced and denoted by  $E_2 \circ E_1$  and interpreted as  $E_2$  applied after  $E_1$ . We use the existing buttons in GeoGebra for constructing the images of a geometric object under translation  $T_{\vec{v}}$ , central symmetry  $C_O$ , reflection  $S_l$  and rotation  $R_O^\alpha$ . In order to explore the composition of two translations we construct the image  $f'$  of the object  $f$  under translation by  $\vec{u}$  and then  $f''$  of  $f'$  under translation by  $\vec{v}$ , denoted by  $f'' = T_{\vec{v}} \circ T_{\vec{u}}(f)$ .

We draw the attention of the students that  $T_{\vec{v}} \circ T_{\vec{u}}$  means that first the transformation  $T_{\vec{u}}$  is performed after which the image undergoes the transformation  $T_{\vec{v}}$ . The students are investigating the conditions under which  $f$  and  $f''$  coincide; what happens if the vectors are parallel, what the result would be if first a translation by  $\vec{v}$ , and then by  $\vec{u}$  is performed. Considering some special cases and special conditions is an essential part of the experiments. To provoke the intuition of the students and to form the necessary skills for looking for such conditions and cases are important tasks for the teachers.

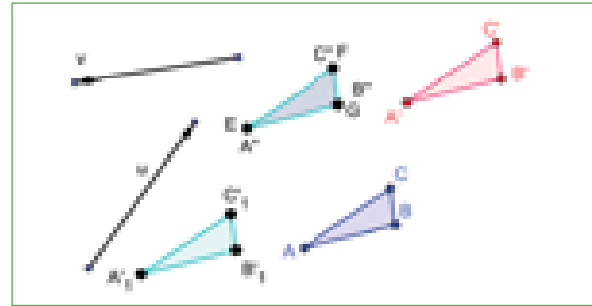
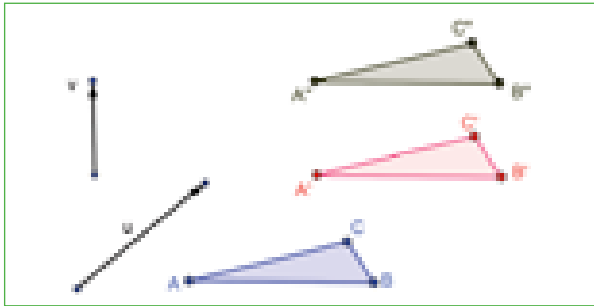
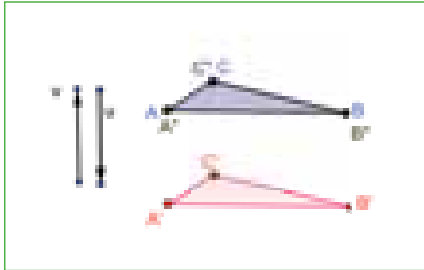

Fig. 27 – 29: Investigating the composition of two translations



Changing the order of the vectors does not influence the result so the students would conjecture that  $T_{\vec{v}} \circ T_{\vec{u}} = T_{\vec{u}} \circ T_{\vec{v}}$ , i.e. that the composition of two translations is commutative. In addition, the transformation under which  $f''$  is the image of  $f$  is again a translation with a vector equal to the sum of  $\vec{u}$  and  $\vec{v}$ . The proof of these two conjectures is accessible for the students.

**This raises new questions:**

*Is it true that the composition of two congruencies is commutative for all the congruencies?*

*Is the composition of two specific congruencies a congruence of the same type?*

It is easy to see that the composition of two reflections is not a reflection. This could be done by finding a counterexample or by changing the orientation of the figures.

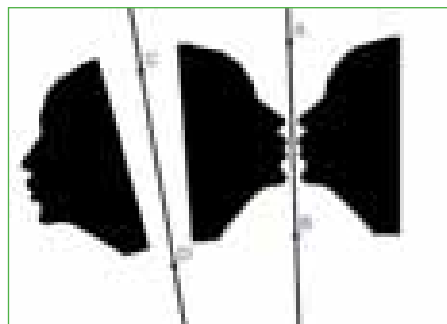
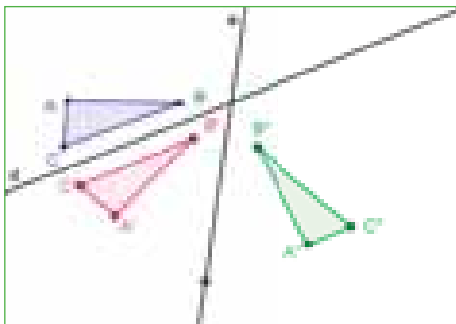
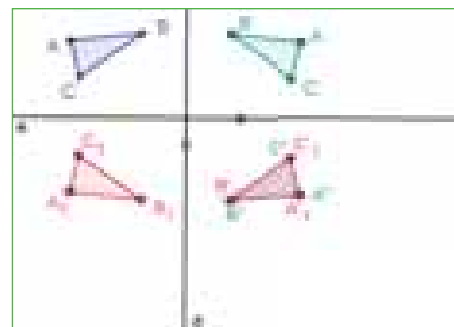
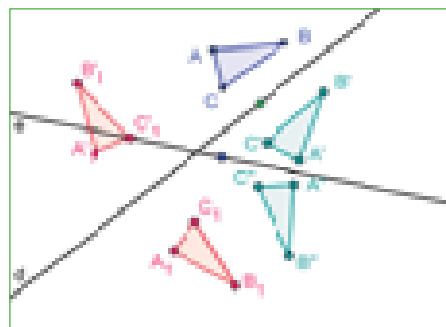

Fig. 30 – 33: Investigating a composition of two reflections



Some interesting cases of compositions of two rotations are the ones with a common centre, as well as some special sums of angles. The students can establish that the composition of two rotations is not commutative in general but the composition of two rotations with a common centre is.

Here is the natural place to give the students the task of modeling objects of art, architecture, museum artifacts based on rotational symmetry – e. g. ceramic plates, wood carved ornaments, church windows, etc. <sup>56</sup>.



Fig. 34 – 37: Objects based on a rotational symmetry as a suitable source of dynamic models.



To create dynamic models of such rotational objects the students discover the relation between the angle of rotation and the number of the rotations in the composition leading to a total turn of  $360^\circ$  (Fig. 38 – 39).

Fig. 38 – 39: Investigating a composition of rotations

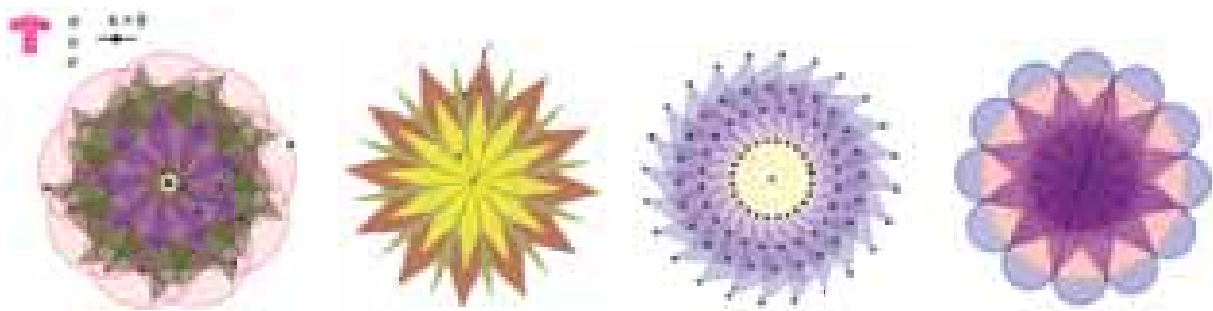
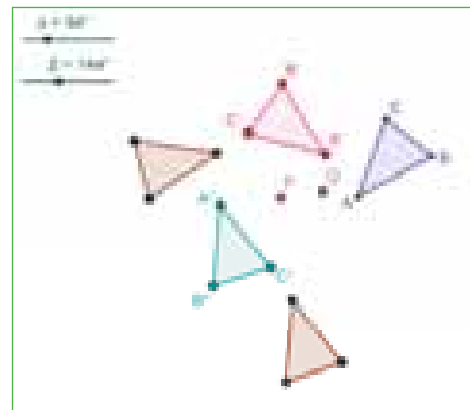
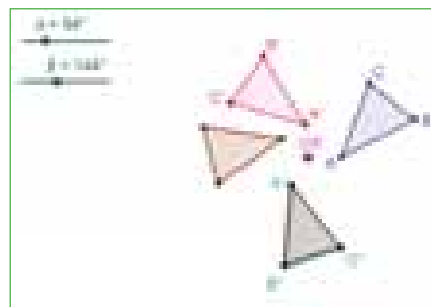

Fig. 40 – 43: Rotational objects modeled by students

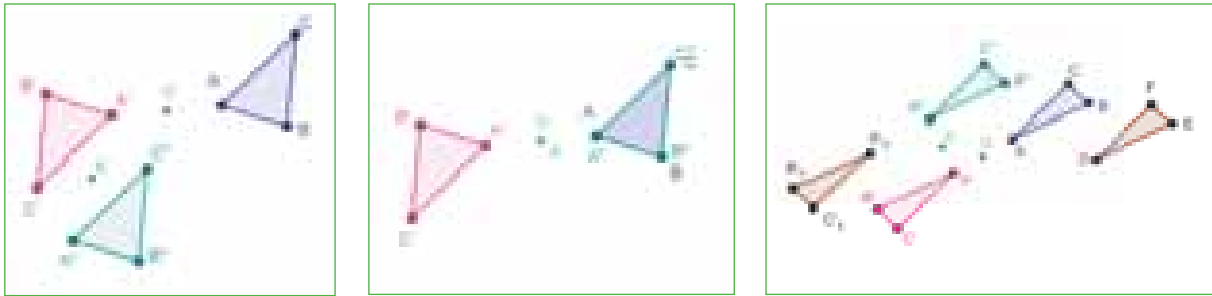

Fig. 44 – 46: Investigating a composition of two central symmetries

When some elements of analytic geometry are studied the compositions of congruencies could be considered again and the proofs could be done with new means.

After exploring the compositions of congruencies of the same type it is natural to continue with explorations of compositions of congruencies of different type, e.g. a reflection and a translation.

First, it is seen that the composition of these two congruencies is a congruence itself.

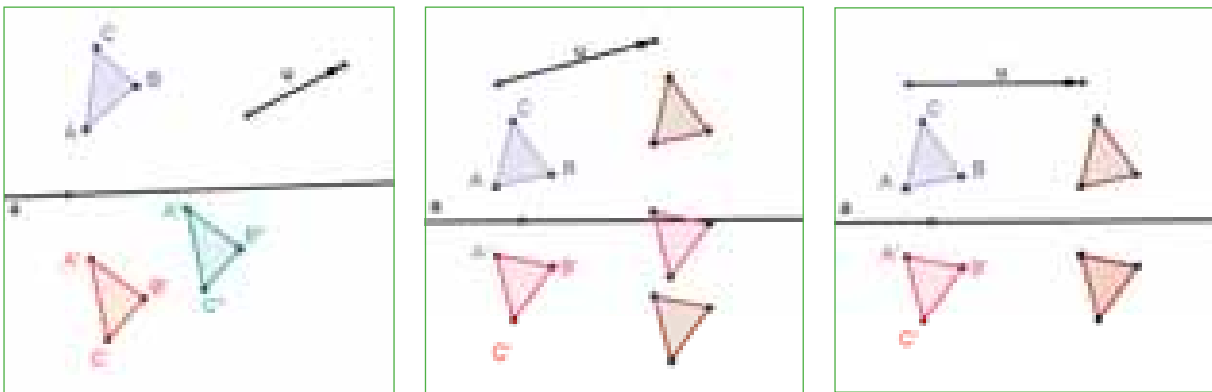

Fig. 47 – 49: Investigating the composition of a reflection and a translation

In the general case the composition of a reflection and a translation is not commutative. The equality  $S_l \circ T_{\vec{v}} = T_{\vec{v}} \circ S_l$  is reached when  $\vec{v}$  is parallel to the axis  $l$ . This is the reason for giving a special name to this congruence, viz. *translational symmetry* or *gliding reflection*.

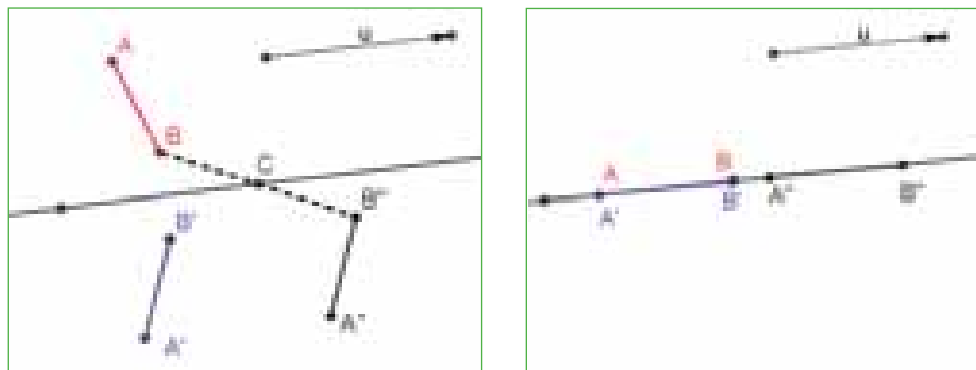
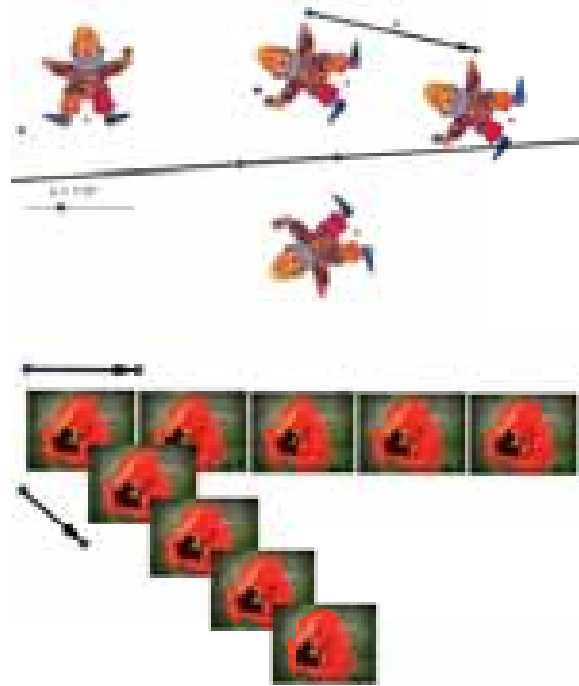

Fig. 50 – 51: A gliding reflection



A further step is to consider the composition of three and more congruencies. It is appropriate to use pictures as proto-images and to include animation:



The work on such a project involves artistic creativity and could serve as an example of extending the means of self-expression by applying mathematics and digital technology.

Fig. 52 + 53: An animation effect with a composition of three congruencies

## Presenting congruencies as a composition of two reflections

Let  $f$  and  $f'$  be a figure and its image under rotation. We shall try to get  $f'$  by making  $f$  undergo a composition of two reflections. The proto-image being  $\triangle ABC$  we construct  $\triangle A'B'C'$  by rotating  $\triangle ABC$  with centre  $O$  and angle  $\alpha$  (Fig. 54). We construct then two lines  $a$  and  $b$ , the image  $\triangle A_1B_1C_1$  of  $\triangle ABC$  under reflection with axis  $a$ , the image  $\triangle HJI$  of  $\triangle A_1B_1C_1$  under reflection with axis  $b$  (Fig. 55). We try to make  $\triangle A'B'C'$  and  $\triangle HJI$  coincide by moving the lines  $a$  and  $b$  (Fig. 56)<sup>57</sup>.

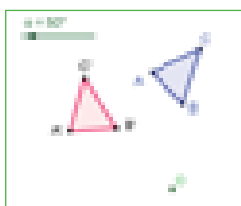

Fig. 54: Rotations and ...

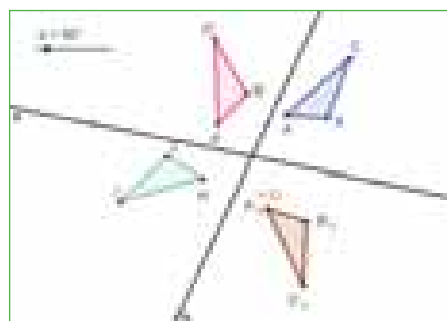

Fig. 55: ... compositions of two reflections

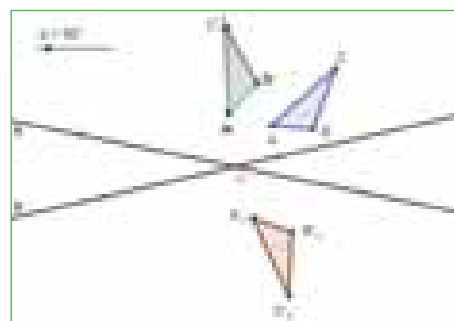

Fig. 56: Moving lines  $a$  and  $b$

### The natural question now is

*if this is the only possible way to present the rotation as a composition of two reflections, i.e. if there is another configuration of  $a$  and  $b$ , in which  $\triangle A'B'C'$  and  $\triangle HJI$  coincide.*

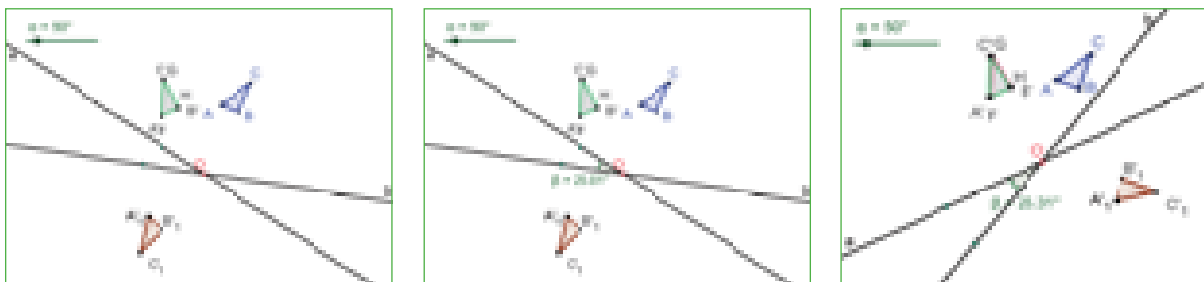

Fig. 57 – 59: The rotation as a composition of two reflections

We notice that in both cases  $a$  and  $b$  meet at the center of rotation  $O$ . To facilitate the investigation we make a new construction, in which  $a$  and  $b$  meet at this centre (Fig. 57 – 59).

If we fix  $a$  and move  $b$  we notice that the triangle *rotates* around  $O$ . To illustrate different positions of  $\Delta FHG$  in our new construction we can make use of the *trace mode* option when moving the image of  $\Delta A_1B_1C_1$  under reflection with respect to  $b$  (Fig. 60).

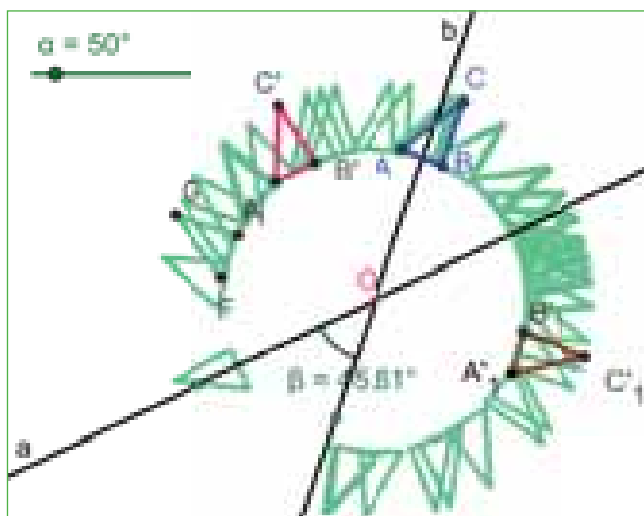

Fig. 60: Images in the case of fixing the first axis of symmetry and changing the other one

This construction gives the students an idea how to prove their conjecture that *the rotation can be presented as a composition of two reflections*.

Before starting the proof though the students could easily check the result for other angles of rotation by means of a slider (Fig. 61 + 62). Thus they would verify experimentally their conjecture and would strengthen their intuition about its truth or alternatively, would reject it if finding a counterexample.

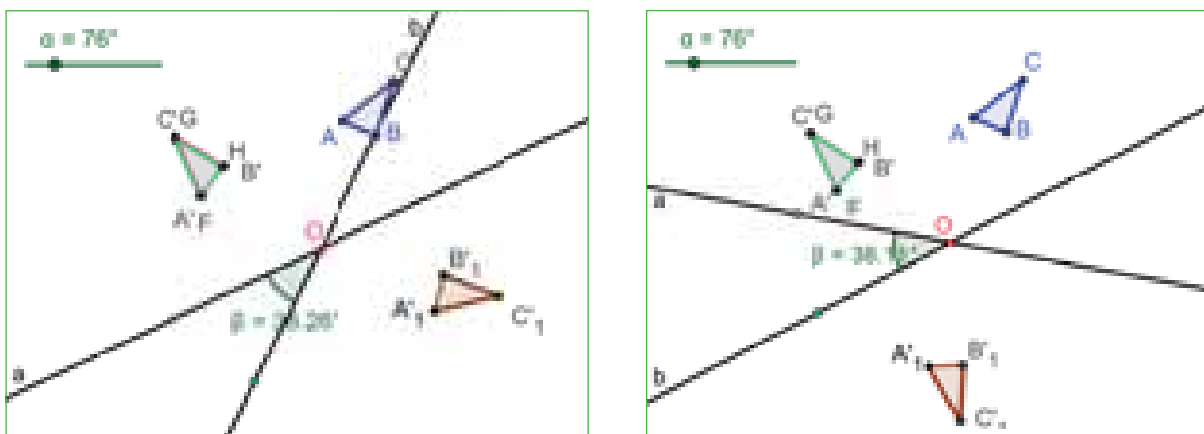

Fig. 61 + 62: Verifying the hypothesis with another angle of rotation

Furthermore, it is worth looking for patterns and relationships by means of the dynamic construction, e.g. whether there is a relationship between the axes of reflection  $a$  and  $b$ . To check this the students could observe the angle between them when  $\triangle A'B'C'$  and  $\triangle FHG$  coincide. They should notice that this angle is twice smaller than the angle of rotation.

It is a good idea to draw the attention of the students not only to the mathematical content in terms of facts, properties and theorems. It is very important to discuss the process of inquiry, the way of creating special conditions, the formulation of the conjectures and the different levels of experimental verification as well as to the necessity of a strict proof (see also [chapter 3.1](#) in this volume).

Then we could continue the explorations with more attractive figures:

**Problem:**

Transform the following images (Fig. 63 + 64) by means of specific compositions of reflections and formulate your conjectures:

Fig. 63 + 64: Compositions of reflection

At the end we would like to share a puzzle presented to us by the Canadian mathematician Andy Liu at the Congress of the *World Federation of National Mathematics Competitions* held in Bulgaria in 1994.

## A challenging puzzle

**Problem:**

Copy the following 3 images on a transparency and cut them in 3 parts as shown in Fig. 65. Get 3 riders on 3 horses.

Fig. 65

The puzzle is really challenging and we have given it as a *warming up* problem or as a *mathematical dessert* to students at different age and background, even within the RSI international program for highly achieving students in mathematics and science (regarding RSI see also [section 6.3](#)):



Fig. 66 – 69: Students from RSI 2012 (the upper row) and from a school in Novi Sad within the Fibonacci project centre twinned with IMI-BAS (the bottom row)

Fig. 70: Chinese paper cut out – an unexpected hint of the 3-horses-3-riders puzzle



Different solutions have been suggested (including going in 3D) but the original one (based on 3-fold rotational symmetry) is breathtaking with its beauty and elegance. As one of the students pointed out the problem surely has been inspired by a famous Chinese paper cut out (Fig. 70).

#### 4.5.2.2 Dynamic tessellations

The *tessellations* – a special case of wall-papers in which the motifs interlock perfectly to fill the plane without gaps or overlapping, proved to be an object of exploration with a great appeal to the students. The tasks in the context of *tessellations* can be organised so that the students would have to combine mathematics and informatics skills of different levels <sup>58–61</sup>.

To modify a regular polygon tessellating the plane by implementing geometric congruencies so as to obtain a tile with a new shape is an idea that has been implemented in a Fibonacci dynamic scenario discussed in <sup>62</sup>. Below we present a fragment of this scenario with some comments and impressions of its further development.

## How to transform dynamically a regular hexagon in a new tessellating tile

Let us illustrate the idea of dynamic tessellations by transforming a hexagon tile in a tessellation tile of a new shape. We construct the regular hexagon **ABCDEF** as a partial case of the *regular polygon* tool, select a point **G** on its side **AB** and point **M** from its inside. We transform the hexagon by *cutting out* the triangle **GBM** and *gluing* it to a neighboring side, e.g. **BC** (Fig.71). We are using **BC** with the idea of making the common vertex **B** a center of rotation. We then construct the images of **G** and **M** under rotation with a center **B** and angle of  $-120^\circ$ , connect them and get a newly shaped tessellation tile.

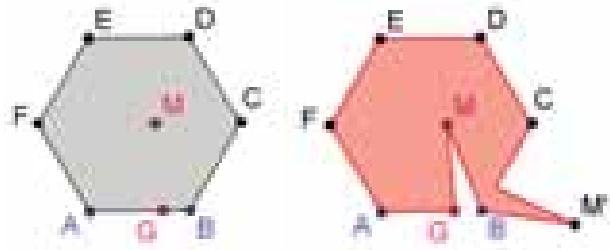

Fig. 71: Transforming a regular hexagon in a newly shaped tessellation tile

Now we could tessellate the plane with this tile by means of the same rotation, and then – by translation (Fig. 72):

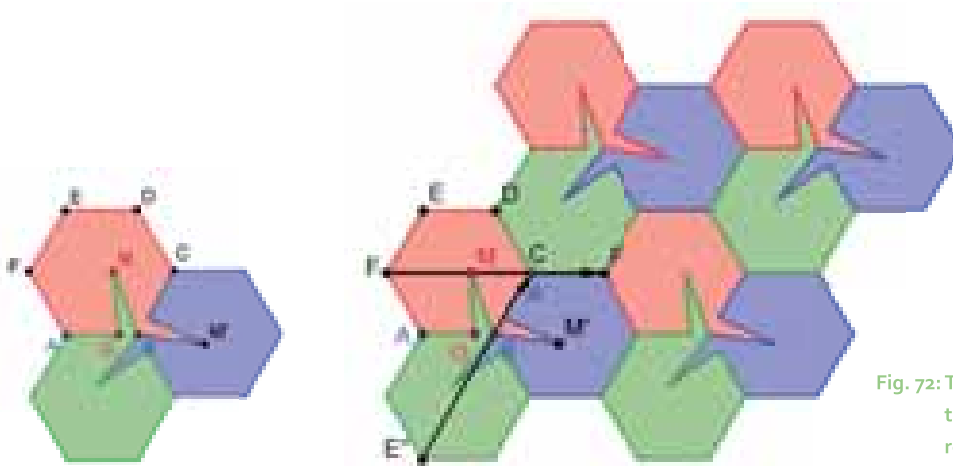

Fig. 72: Tessellating the plane with the new tile by means of a rotation and a translation

We have hidden some of the points and/or their names for convenience. We could use other ways for connecting the tiles but it is sufficient to move only **G** and **M** to modify the tessellation.

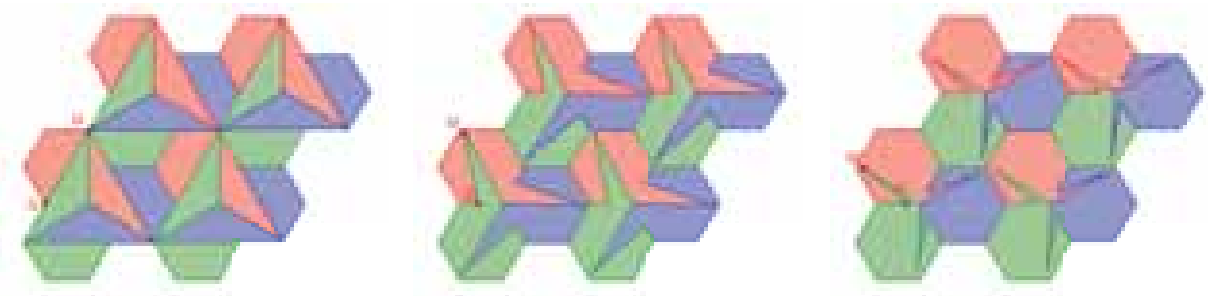

Fig. 73 – 75: Modifying the tessellations by moving two points only

The tessellations in Fig. 73 – 75 are a result of moving the point **G** and **M** by hand. We could animate the construction automatically by constructing sliders for the movement of **G** and **M**.

The point **G** is the intersection point of the segment **AB** and the circle with a centre **A** and a radius **r** (a variable). To assure the existence of the point **G**, the upper limit of **r** is chosen to be close to (less than) the length of **AB**.

The point **M** will also lie on a preliminary constructed object, dependent on variables. In our case **M** is an intersection point of the circle with a centre **H** (the centre of the regular hexagon) and a radius **k** (a variable), and the second ray of the angle with a vertex **H**, a measure  $\alpha$  (a variable), and a fixed first ray (all the variables are represented by the sliders in Fig. 76 + 77).

What is left is to hide the auxiliary elements and to run the sliders in an animation mode.

These are just a few of the possible ways to create a newly shaped tile by transforming a regular hexagon, to tessellate the plane with it, and to animate the tessellations. But even they give an idea how the topic of dynamic tessellations could be used in support of the inquiry-based learning of mathematics and arts.

Let us remind that creating tile shapes was almost an obsession with the great Dutch artist M. C. Escher – *he would begin with a simple tile (often a polygon) that he knew would tessellate the plane, and then painstakingly coax the boundary into a recognisable shape*<sup>63</sup>. More formally, the tessellation of the plane in the style of Escher (known also as *Escherization*) could be formulated as follows<sup>64</sup>:

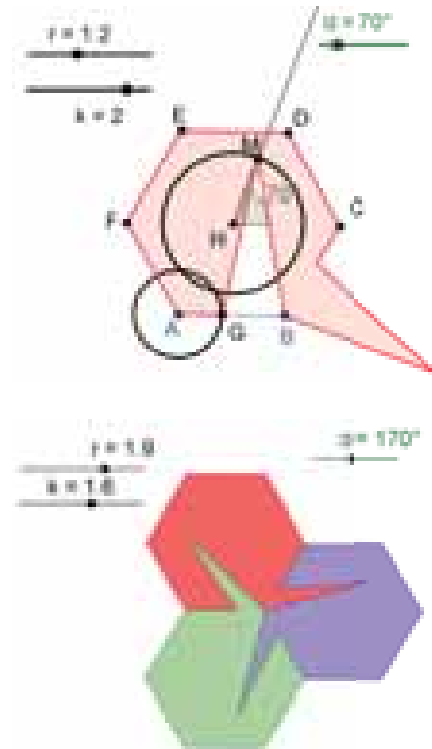

Fig. 76 + 77: Organising the animation effect of the tessellation

### The Escherization problem

Given a shape *S*, find a new shape *T* such that:

- *T* is as close as possible to *S*; and
- Copies of *T* fit together to form a tiling of the plane.

### Playing Escher in a class setting

The whole scenario on dynamic tessellations was presented in a Bulgarian journal in mathematics and informatics with detailed instructions for working in *GeoGebra*. Ms. Elisaveta Stefanova, a teacher from the 73 High School *Vladislav Gramatik* within the *Fibonacci* project, took the gauntlet and implemented it with 7th-graders in IT classes. Here is what she shared with us: *The students started with the regular polygons tessellating the plane and followed the ideas of transforming a tile by means of dynamic constructions as presented in the tessellation scenario. Soon they realised that they had discovered their own land for explorations – playing in the style of Escher by adding new points on the initial tessellating tile (square, triangle, hexagon, rhombus) and modifying it under various congruencies so as to get beautiful tiling shapes* (Fig. 78 – 83).



Fig. 78 – 83: Escherizations by several students, parents and teachers – flowers, several metamorphoses of animals and a poster: *Save the water!*

The most interesting part of this learning experience was that it continued after the classes, even after the school year – the most recent works of the students were sent a day before this material was submitted. In a recent mail to us Ms. Stefanova wrote about the continuous excitement of her students, their parents, and her colleagues in mathematics and art:

*I realised from the interest of the students that the congruencies are a very attractive topic. Given as in the Fibonacci project scenario these transformations are not only understandable but very useful for art applications. The students get the feeling of discoverers and creators, and this is a real thrill for them and the teacher. Learned that way the congruencies are easy to remember and apply in various situations. I am convinced that every colleague who is ready to try this will be inspired by our enthusiasm and will implement this approach. Our students deserve that we make their learning process interesting and appealing to them.*

The best works of the students were published on the *Fibonacci* project website and later presented in the form of book markers, greeting cards and framed paintings at a seminar within the 41st Spring Conference of the Union of Bulgarian Mathematicians (Borovets, April 9-12, 2012, see also [section 5.3](#)).

## 4.6 IBME in the secondary school: Examples from Switzerland

### 4.6.1 On the equilibrium between offer and use – a practical example from a Swiss Upper Secondary School: The offer-and-use model within the context of dialogic learning

*Peter Gallin*

Within the EU-Fibonacci Project, the Swiss Twin Centre (University of Zurich) entirely focussed on inquiry-based mathematics education (IBME). To this end, *dialogic learning* was used as a base concept (cf. [chapter 2](#)). In the following, a close look at the offer-and-use model shall shed light on the concept of *dialogic learning*, which will

be underpinned by a practical example taken from our Sekundarstufe II (upper secondary level). To this end the *dialogic learning cycle* (introduced in section 2.3) will be divided into two parts: one is concerned with what the teacher offers, while the other relates to what use the learner makes of this offer, which is, in fact, the student's overall responsibility. This kind of view of school in general and classroom lessons in particular, in which a distinction between offer and use is drawn, originally goes back to Prof. Helmut Fend of the University of Zurich\* and can be flawlessly embedded in the *dialogic learning cycle* (Fig. 84). Thus, core idea and task (assignment) construction belong to the offer that the teacher makes, while keeping a journal and receiving (or giving) feedback are entirely centered on the learner's work responsibilities. Indeed, the student will perform these activities in the course of working on his tasks. The norms – i.e. the theories and rules that the curriculum expects the students to learn – form the goals of *dialogic learning* and should, ideally, result from the fusion of offer and use. Thus, the norms do not make the starting point but follow as consequences in later classroom units.

Central to this model is the fact that the quality of a classroom lesson is at its highest if the time available is evenly distributed to both parts of offer and use. This then means that about half the time should be used in conjunction with the use-part, i.e. the question how students understand and process the objects they are given to deal with. This kind of requirement strongly contrasts with how lessons are taught at most schools. In fact, this valuable approach is hardly even treated during vocational teacher training. Even within the Fibonacci project, what often seems to be at the centre of investigations is the quest only to make what the teacher offers more interesting and maybe more closely related to real-life problems. The phenomenon of putting excessive emphasis on what the teacher can do is widespread since teachers naturally ask themselves what they can do to improve the situation. However, as it is impossible to foretell what the students will make of the (improved) offer, the sight of student use is often lost at the planning stage. Moreover, the fact that student reactions cannot be planned for, and will often vary depending on the exact circumstances, is a real dilemma for innovative approaches. Then again, a hopefully successful IBME approach should set out to assume that all results can be foretold by the teacher. If this were possible, it would invariably imply that there is no room for genuine student inquiry. As a consequence of this, inquiry-based education is only possible if the emphasis is put on the student's use of what is offered and if this use makes the central aspect in the classroom. It goes without saying that this, in turn, presupposes an accordingly stimulating teacher offer.

*Dialogic learning* is permeated by journal entries and through it the extent to which a student engages with the task offered is given the necessary weight. The dialogic approach is, thus, situated somewhere between instruction and (knowledge self-) construction. At the same time, it takes into account that knowledge transfer through instruction (offer) is quite effective, but that real learning is a constructive process (use) where self-motivated learning brings about truly lasting and flexible results.

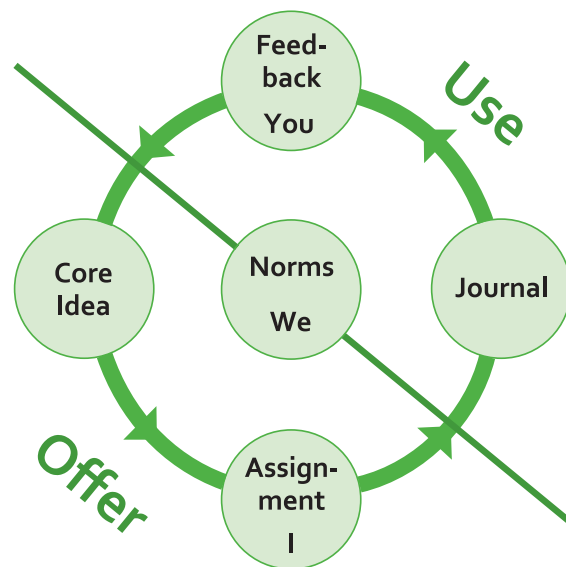

Fig. 84: The offer-and-use model within the cycle of *dialogic learning*

\* For an explanation on the offer-and-use model <sup>65</sup>(p.14).



The shift of emphasis towards the aspect of use simultaneously moves the burden away from the teacher: more than ever, he is now in a position to concentrate on the learning goals set in the curriculum, and does not have to plan innumerable lessons in advance\*. In other words, the offer can be a simple one and, thus, the pressure exerted by time management issues is greatly reduced. At this point in our article, another aspect in the discussion revolving around improvement to the classroom needs to be addressed. It is often postulated – by laymen and professionals alike – that the quality of mathematics lessons can be improved by more frequently relating the mathematical aspects in question to real-life situations. It is generally felt that only these situations can lead to successful inquiry-based work. The latest studies in this field contradict this view. In connection with Anna Susanne Steinweg's thesis<sup>66</sup> the Madipedia<sup>67</sup> index of the institute for mathematical didactics notes,

*The main result of this study is that more than half the participating children were able to recognise and describe number patterns even though they had not received prior tuition in connection with number patterns at all. When presenting the tests to these children, the author purposely refrained from setting the patterns into context or relating them to real life. The circumstance that the children worked on the task with motivation strongly hints at the fact that mathematics in its pure form is appropriate for children.*

Thus, even for children at primary school level, the relation of mathematics (or its absence) to everyday life or to real-life applications is not a crucial factor when it comes to motivation. What is important, however, is that the learner is given an adequate period of time to deal with a mathematical topic and that the learner's effort to gain insight into such a topic is duly appreciated. In a school class with more than 10 people, this is only possible if each single student is given adequate space and can voice his thoughts in a learning journal.

Through their study, Deci and Ryan have shown that this procedure influences the learners' motivation the most<sup>68</sup> (p. 68–78). According to the authors, the three basic pillars are "experience of autonomy", "experience of social embedding", and "experience of competence". Exactly these three experiences are central to *dialogic learning*: the self is allowed to experience autonomy through the task because it is allowed to give voice to its thoughts and feelings. Social embedding is created by feeding back authentic student texts to the whole group. Finally, it is the teacher's duty to collect and bring together subject theory and insights developed in the student text in such a manner that the students recognise their input and thus experience competence.

Overall, inquiry-based mathematical education is not primarily connected with a given set of topics. Rather, it hinges on the way how tasks for students are formulated (offer) and what the students make of them (use). Through this approach, topics that are ordinarily part of the curriculum can be turned into *dialogic learning* tasks. Already after sifting through a first batch of journals, the teacher can see what insights the students have reached and what problems they have encountered. These aspects can be made essential parts of the next lesson. As a consequence, lesson planning is facilitated and evenly spread across the whole teaching time and does not require to be planned weeks ahead.

In preparation for a more demanding example, we introduce our practical example with a simple task that could not be easier. When teaching children multiplication tables, it is not uncommon to give students a question that does not lead to an investigation and that can only be answered wrongly or correctly: how much is  $49 \cdot 51$ ? The same question can, however, easily be turned into an inquiry-based task by asking, "Show me how you calculate  $49 \cdot 51$ !" It becomes immediately clear that there is no single right answer and that several different approaches will lead to a fruitful class discussion on how to multiply numbers. This will be the case all the more if the students are requested to hand in their personal answers in writing through their learning journals.

## **An actual example from a mathematics course by Bruno Lustenberger**

In accordance with the cycle in Fig. 84, inquiry-based mathematical education will be divided into four stages, which follow the offer-and-use model. These parts together set the minimum that is necessary to show the

---

\* Cf. article by Markus Jetzer-Caversaccio (section 4.6.2)

strength of an inquiry-based working approach in the school context. The following short overview will illustrate the equilibrium between the teacher's offer and the students' use:

- The students are given a task that is closely linked to a topic set in the curriculum and that allows individual approaches. (Initial offer)
- The students keep track of their thoughts, problems and findings in their learning journal. (First use)
- The teacher organises an exchange of thoughts among the learners and gives individual feedback on remarkable insights. (Second offer)
- The teacher collects and re-distributes interesting results as well as findings that allow the group to continue the investigation. (Second use)

The following example from Bruno Lustenberger's classroom (Kantonsschule Glattal, Grammar School at Dübendorf, Switzerland) shows that this approach may, of course, lead to surprising results. His class MN5 (with an emphasis on mathematics and physics) previously treated a number of arithmetic and geometric sequences in a traditional way. Let us now take a close look at how the four stages of inquiry-based mathematics education developed in his class in November 2011.

**First offer: the task (assignment)**

- *Try to define and investigate at least one more type of a sequence.*
- *If possible, write down both the recursive and the explicit formula for your sequence(s).*
- *Illustrate your sequence(s) with examples.*

**First use: the journal of Abdullah, Ceren and Kevin**

The work of Abdullah, Ceren and Kevin is used to represent the great number of contributions that are exceptionally interesting and that merit a thorough inspection. To start with, the three wrote, "Up to now, we have always added a fixed number to get to the next term. Now, we will remove the 'fixed', and if we do this, then the sequence of differences between two terms in itself becomes a sequence [an arithmetic sequence]." They continued to investigate the sequence 1, 2, 4, 7, 11, 16, 22, 29, ... where the terms in the sequence of the differences are natural numbers. Because they were already familiar with the formula for the series of the first  $n$  natural numbers, they concluded that the explicit formula for their sequence should be

$$a_n = a_1 + \frac{n(n-1)}{2}.$$

After a second but not quite successful example – the sequence of perfect squares – and in order not to become lost, they turned to a sequence with greater terms and differences (Fig. 85).

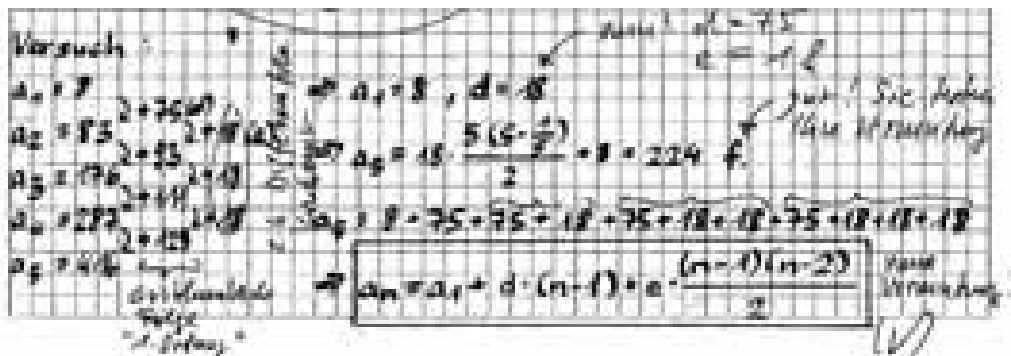

Fig. 85: Investigation of a 2<sup>nd</sup> order arithmetic sequence

Purely to increase legibility, we here provide a transcript of the students' approach:

Term	$a_1$	$a_2$	$a_3$	$a_4$	$a_5$	$a_6$	$a_7$	$a_8$	...
Term value	8	83	176	287	416	563	728	911	...
1. seq. of differences	75	93	111	129	147	165	183	...	
2. seq. of differences	18	18	18	18	18	18	...		

With a certain degree of agility, they investigated how  $a_5 = 416$  had developed from the first term  $a_1$ , the starting number 75 in the first sequence of differences and the starting number 18 in the second sequence of differences:

$$a_5 = 416 = 8 + \overbrace{75}^{93} + \overbrace{75 + 18}^{111} + \overbrace{75 + 18 + 18}^{129} + 75 + 18 + 18 + 18$$

The students recognised the pattern  $a_5 = 8 + 75 \cdot (5 - 1) + 18 \cdot \frac{(5-1)(5-2)}{2}$ , introduced the parameters  $d = 75$  and  $e = 18$  and concluded that:

$$a_n = a_1 + d \cdot (n - 1) + e \cdot \frac{(n-1)(n-2)}{2}$$

Inspired by their success, they made a forecast (albeit a wrong one to start with) for the next higher stage, i.e. a sequence where only the 3<sup>rd</sup> sequence of differences would be constant:

$$a_n = a_1 + d \cdot (n - 1) + e \cdot \frac{(n-1)(n-2)}{2} + f \cdot \frac{(n-1)(n-2)(n-3)}{3}$$

Fig. 86 shows this extract from their learning journal.

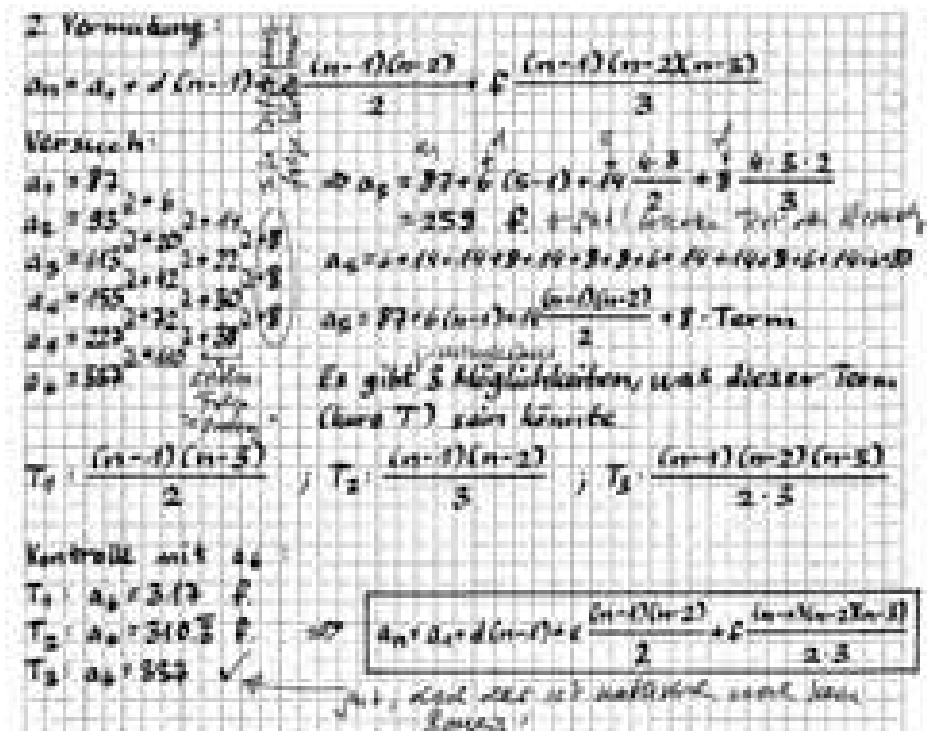

Fig. 86: Investigation of an arithmetic 3<sup>rd</sup> order sequence

For their example, the three students chose the new sequence

Term	$a_1$	$a_2$	$a_3$	$a_4$	$a_5$	$a_6$	...
Term value	87	93	113	155	227	337	...
1. seq. of differences	6	20	42	72	110	...	
2. seq. of differences	14	22	30	38	...		
3. seq. of differences	8	8	8	...			

Once again, they applied their method of back tracing to the first terms of the sequences of differences and inspected:  $a_5 = 227$

$$a_5 = 227 = 87 + \overbrace{6+6}^{20} + \overbrace{14+6+14+14}^{42} + \overbrace{8+6+14+14+8}^{72} + \overbrace{14+8+14+8+8}^{30}$$

They were only unsure about the number of terms (summands) 8 and so wrote

$$a_5 = 227 = 87 + 6 \cdot (5-1) + 14 \cdot \frac{(5-1)(5-2)}{2} + 8 \cdot \text{Term},$$

where "Term" stands for one of the three expressions

$$T_1 = \frac{(n-1)(n-3)}{2}; \quad T_2 = \frac{(n-1)(n-2)}{3}; \quad T_3 = \frac{(n-1)(n-2)(n-3)}{2 \cdot 3}.$$

Thus, they reached the conclusion that  $T_3$  had to be the right one, and again they introduced the parameters  $d = 6$ ,  $e = 14$ , and  $f = 8$ . At this point, they had reached a general and now correct formula

$$a_n = a_1 + d \cdot (n-1) + e \cdot \frac{(n-1)(n-2)}{2} + f \cdot \frac{(n-1)(n-2)(n-3)}{2 \cdot 3}$$

Now, there was no stopping them (Fig. 87). Without knowing the name of their sequence, they successfully put their formula to the test with an arithmetic 4<sup>th</sup> order sequence.

$$a_n = a_1 + d \cdot (n-1) + e \cdot \frac{(n-1)(n-2)}{2} + f \cdot \frac{(n-1)(n-2)(n-3)}{2 \cdot 3} + g \cdot \frac{(n-1)(n-2)(n-3)(n-4)}{2 \cdot 3 \cdot 4}$$

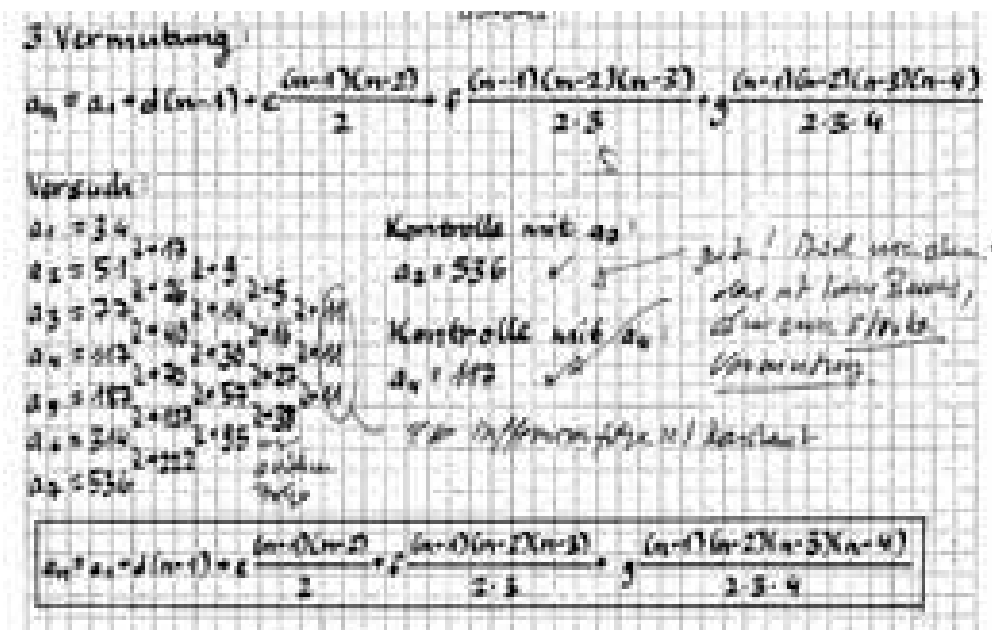

Fig. 87: Investigating an arithmetic 4<sup>th</sup> order sequence

**Second offer: guided reflection and proof by teacher**

In the course of their investigation on “self-made sequences”, the three students developed a building principle for arithmetic sequences of  $k$ -th order, which is probably not widely known. In any case, the teacher had to sit down and verify their hypotheses. Abdullah, Ceren and Kevin proposed that

$$a_n = a_1 + \sum_{i=1}^k \frac{\lambda_i}{i!} \prod_{j=1}^i (n-j)$$

where the coefficient  $\lambda_i$  denotes the first term in the  $i$ -th sequence of differences. It should be noted that

$$\frac{1}{i!} \prod_{j=1}^i (n-j) = \binom{n-1}{i}$$

where any binomial coefficient is zero if  $i > n - 1$ . Furthermore, let  $a_1 = \lambda_0$  and the students’ statement can be compacted into

$$a_n = \sum_{i=0}^k \lambda_i \binom{n-1}{i}.$$

If we now build the first sequence of differences, we find that

$$a_n = a_{n+1} - a_n = \sum_{i=0}^k \lambda_i \binom{n}{i} - \sum_{i=0}^k \lambda_i \binom{n-1}{i} = \sum_{i=0}^k \lambda_i \left( \binom{n}{i} - \binom{n-1}{i} \right) = \sum_{i=1}^k \lambda_i \binom{n-1}{i-1}$$

and through renumbering the summation index as  $j = i - 1$  we obtain

$$d_n = a_{n+1} - a_n = \sum_{j=0}^{k-1} \lambda_{j+1} \binom{n-1}{j}.$$

This, in turn, is the proposed formula but for an arithmetic sequence of order  $k - 1$ , and thus the students' formula has been proved by induction. It may also be noted that the  $k$ -th sequence of differences is the sequence of constants, which only consists of  $\lambda_k$ .

It goes without saying that this proof, especially in its most general form, was not presented in class. While this would have been beyond the scope of the students, the presentation of selected material produced by the students themselves allowed the teacher to draw attention to core ideas relating to binomial coefficients and their sums, which already shined through in the students' table.\*

### Second use: the continuation of the lesson takes an unplanned turn

With the help of the thus developed formula, students can now and on their own solve a problem that a teacher usually has to demonstrate in row of laborious calculations or through proof by induction: finding a formula for the sum of the first  $n$  perfect squares. Based on the above tabling structures for sequences and their underlying sequences of differences, it becomes clear that the series of perfect squares is a 2<sup>nd</sup> order arithmetic sequence (highlighted in the following table). As a consequence, its partial sums build an arithmetic 3<sup>rd</sup> order sequence. In keeping with the above tabling structure, we obtain:

Term	$a_1$	$a_2$	$a_3$	$a_4$	$a_5$	$a_6$	...
Term value	1	5	14	30	55	91	...
1. seq. of differences	4	9	16	25	36	...	
2. seq. of differences	5	7	9	11	...		
3. seq. of differences	2	2	2	...			

Thus,  $a_1 = 1$ ,  $d = 4$ ,  $e = 5$  and  $f = 2$ , and for the general term of this 3<sup>rd</sup> order sequence we find

$$a_n = 1 + 4 \cdot (n-1) + 5 \cdot \frac{(n-1)(n-2)}{2} + 2 \cdot \frac{(n-1)(n-2)(n-3)}{2 \cdot 3}$$

A simple term manipulation results in the well-known formula for the sum of the first  $n$  perfect squares:

$$a_n = \frac{n^3}{3} + \frac{n^2}{2} + \frac{n}{6} = \frac{n(n-1)(2n+1)}{6}$$

\* Holger Stephan <sup>69 (p.10)</sup> deals with the same insight that the students Abdullah, Ceren and Kevin had.

This now opens the flood gates for formulae for series of natural numbers with higher exponents. From the respective table for the 1<sup>st</sup> sequence of differences 8, 27, 64, 125. ... (which the reader may do himself) follows that

$$\sum_{i=1}^n i^3 = 1 \cdot \binom{n-1}{0} + 8 \cdot \binom{n-1}{1} + 19 \cdot \binom{n-1}{2} + 18 \cdot \binom{n-1}{3} + 6 \cdot \binom{n-1}{4} = \frac{n^2(n+1)^2}{4}.$$

## Conclusion

Inquiry-based mathematical education (IBME) can start with elementary questions, will often take an unplanned turn, may lead to a subject-related in-depth discussion, and enables the learner to gain insight into the methods and thinking of co-students.

### 4.6.2 Dialogic Learning: An example from a classroom situation at lower secondary school level

#### Pyramids

Markus Jetzer-Caversaccio

#### Introduction

The following classroom example is from a year-9 group of students within an extended study module, i.e. the highest level at lower secondary school in the canton of Zurich. This group (Fig. 88) has studied all geometrical topics of our curriculum through *dialogic learning*. "Pyramids" was the first topic, but the students had already received instructions into how to deal with dialogic learning tasks for parts of arithmetics and algebra. Thus, they had already gathered experience with this type of learning, particularly with writing journals.



Fig. 88: Group of students involved in extended study module

#### Core idea and start of the journey

Before I set a task, I reflect on why a certain topic fascinates me, what catches my attention or what surprises me. The thoughts are jotted down and I try to work out a suitable task for the start of a student's journey into the area connected with the topic. For pyramids, I came up with: "I am fascinated by the variety of pyramids. The mathematical definition differs completely from the intuitive 4-sided right pyramid."

The students received the following instructions and were given 45 minutes to work on the task and keep track of their working in their journals (Fig. 89).

- Given a piece of paper (DIN A3: 297mm x 420mm), scissors and glue, construct the biggest pyramid possible.
- Write down your thoughts and keep track of your way of working in your journal.
- Write down your personal definition of a pyramid.

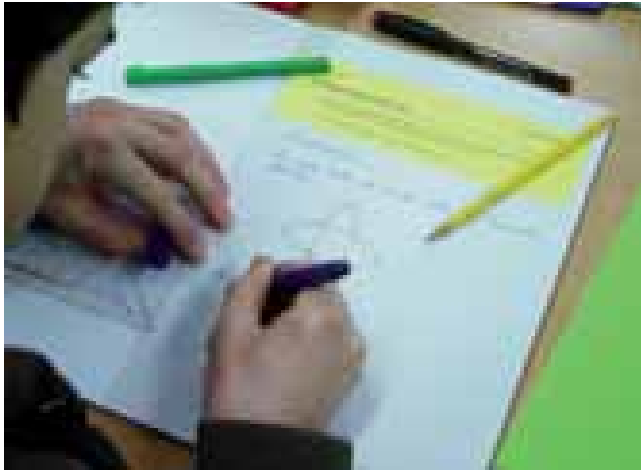

Fig. 89: The journal

The deliberate openness of the task resulted in a great variety of pyramids (Fig. 90).

I collected all the journals and viewed them. From the students' texts, I distilled a text collection, which I handed out to the whole group. In the follow-up lesson, the authors of these texts, i.e. the students themselves, presented their contributions, discussed and analysed them with their peer group. As anticipated, the first sub-topic that automatically came up was "nets". The collection of texts (Fig. 91) also gave rise to a debate about flaps to glue to the pyramid and how to draw nets.



Fig. 90: A great variety of pyramids

Josua drew unnecessarily many flaps, noticed it and then shaded the superfluous ones. The group quickly discussed his technique, which required paper and glue. Another student proposed a version with adhesive tape in order to save paper. However, many students were against the idea as the pyramid did not look nice and turned out to be unstable.

Christian and Steven sketched two variants of pyramid nets. Interestingly, their versions coincided with the ordinary nets that would have been in our text book. A question dealing with the number of different nets that all describe the same four-sided right pyramid seemed to be the next obvious choice, and this led to the next student task.



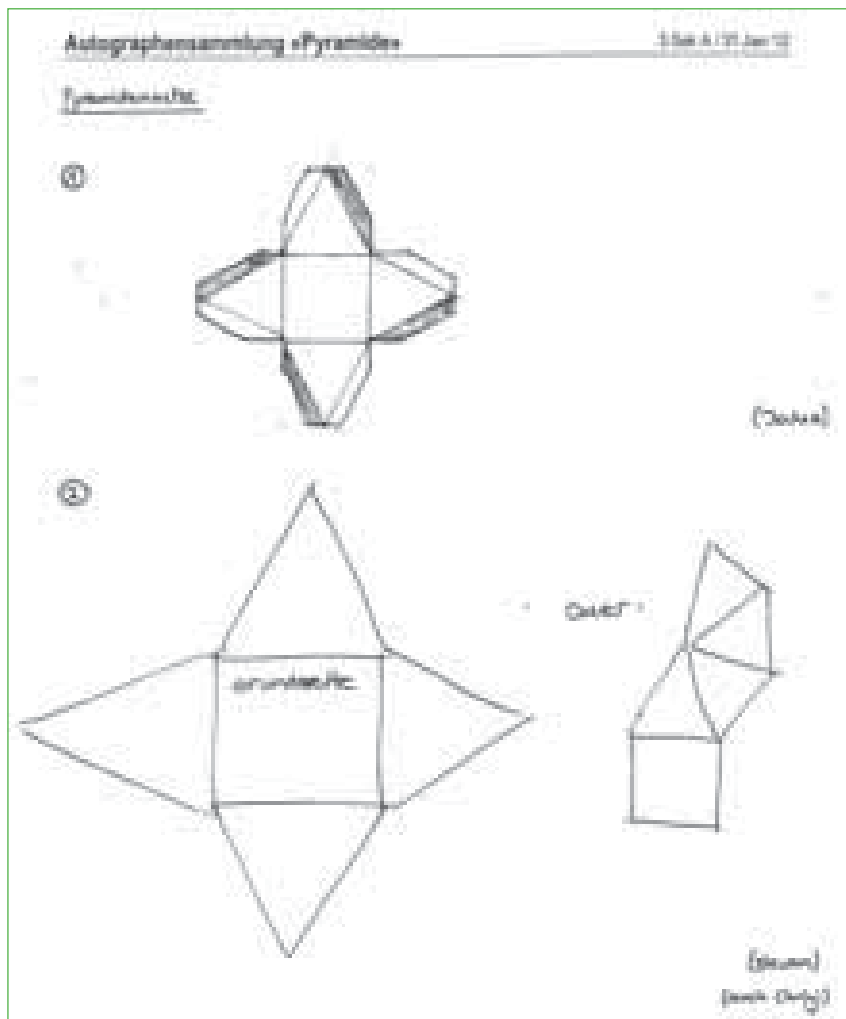

Fig. 91: Worksheet "pyramid" – Collection of student texts

The students handed in an amazing number of ideas. The following shows Michele's sketches (Fig. 92).

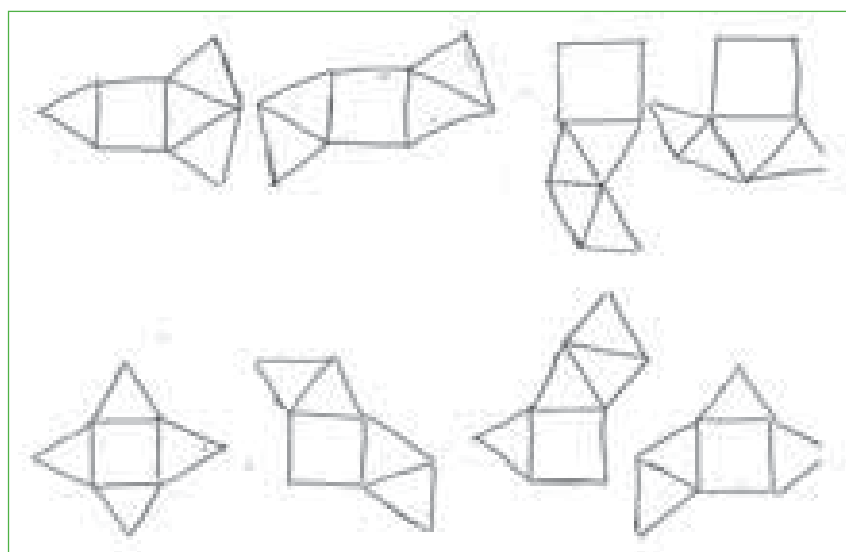

Fig. 92: Michele's sketches

Maren, too, had sketched several versions (Fig. 93).

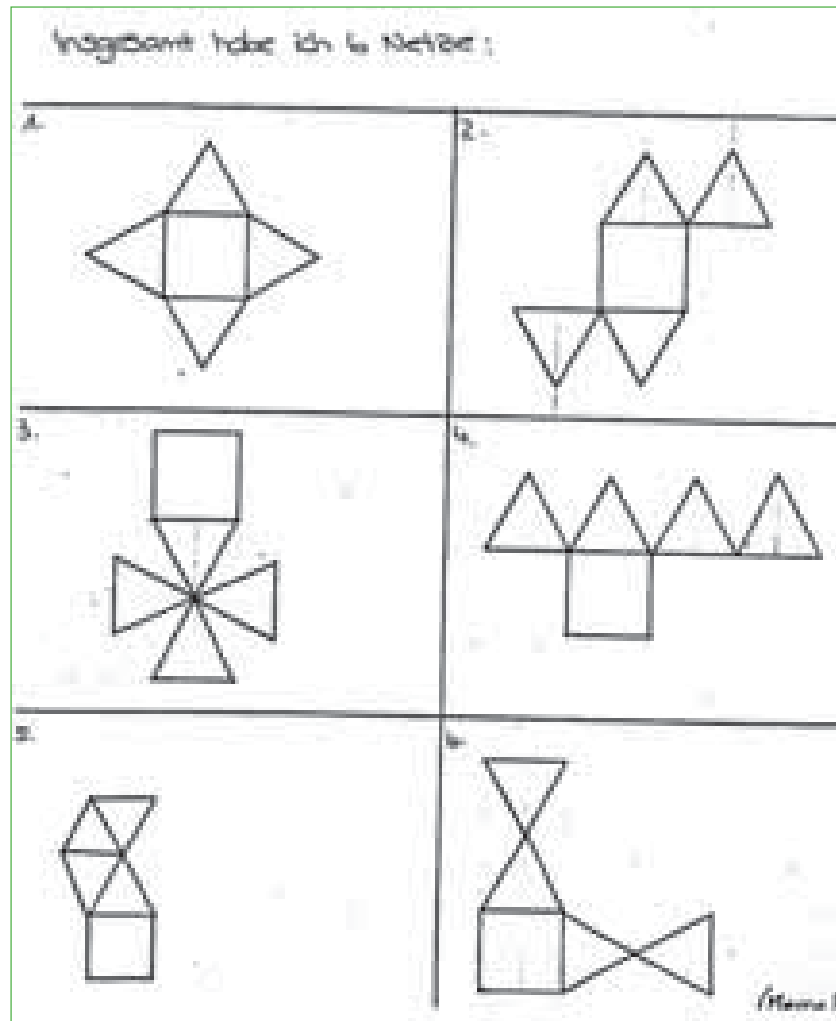

Fig. 93: Maren's sketches

The variety of sketches led to an intense discussion about what characterises a net. So far, there had been no need to define the term. Now, however, the moment had arrived, where it had become necessary to find a definition in order to tell which sketches constituted nets. The group immediately realised that if all of Maren's sketches represented nets, then it was impossible to sketch all versions of nets for a four-sided right pyramid.

The students looked up the definition, and soon enough found themselves confronted with a topic called topology. They found "weird" nets for our pyramid, even ones that led to pyramids that were impossible to build. Surprisingly, however, the given definition did not match any of our shapes. The surprise was big and the new challenge even bigger!

### The journey

During our entire journey through this particular part of geometry, we had always aimed at producing the greatest pyramid and at awarding a price to its constructor. We came across a whole range of topics in connection with our quest. The following list shows a few excerpts from student journals:

### Example 1: A connection between the base area and the lateral area of a pyramid

Pavao wrote (Fig. 94): "Initially, I wanted to produce a pyramid of this kind. However, I was unsure about the size of the square base." Pavao's question concerning the relationship between base area and lateral area seemed relevant to me and so I passed his question on to his peers.

**1.1 Grundfläche einer Pyramide**  
 Untersuche die Zusammenhänge der Grundfläche, hier ein «Quadrat», mit den dreieckigen Seitenflächen. Wie muss dieses Netz aussehen, damit es überhaupt eine Pyramide gibt. Beantworte Pavaos Frage.

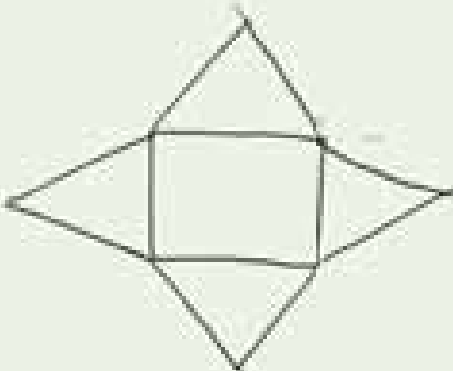

Pavao

Ich wollte zuerst die Pyramide in dieser Art herstellen. Doch ich wusste nicht wie gross die Quadrat Fläche sein soll.

Fig. 94: Base area of a pyramid

**Investigate the relationship between the base area, here a square, and the lateral area consisting of triangles. Answer Pavao's question and find out what the net needs to look like so that it represents a pyramid.**

Michele came up with a highly dynamic answer (Fig. 95).

The presentation of Michele's answer reignited the question concerning the smallest and the greatest pyramid. Obviously, it was possible to change the size of the pyramid by changing a vertex of the triangular sides.

**2. Möglichkeit (quadratische Pyramide)**

Man zeichnet ein Quadrat (z.B. mit einer Seitenlänge von 5cm). Dann halbiert man die Seitenlänge des Quadrats (dies heisst bei 2,5cm). Dann verbindet man die Parallelen markierungen bzw. Halbierungen und von dann man die Eckpunkten des Quadrat beliebig auf dieser Ebene verbindet. Man sollte aber darauf achten, dass jeder Seite das gleiche unternimmt.

Skizze:

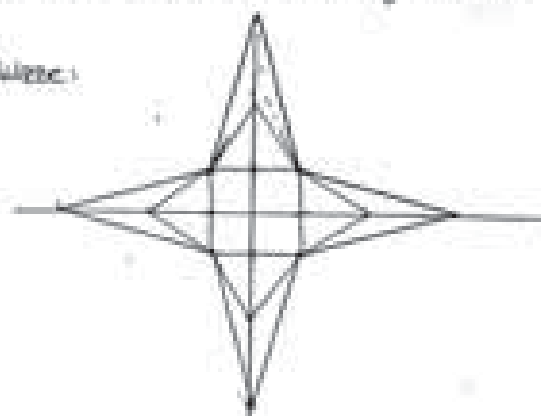

Fig. 95: Michele's answer

### Example 2: Kristina's theorem

Kristina had this proposition: The area of the equilateral triangle equals half the area of the square. However, I believe that this proposition only holds true for right pyramids (Fig. 96).

Her peers were asked to investigate this particular proposition. They soon found that it was not true. Even Kristina herself realised why it was flawed. Nevertheless, the verification of her proposition constituted an important point during our journey, and the proposition itself was both a surprise and led itself to a very nice task.

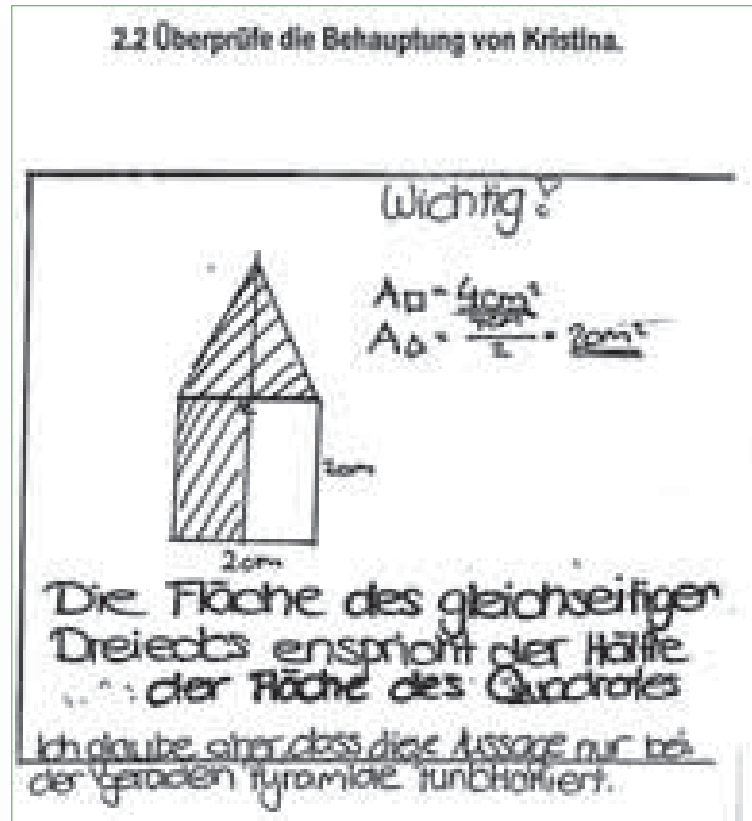

Fig. 96: Kristina's theorem

### Example 3: On the relationship between volume and surface area of a pyramid

In her journal, Blerta proposed that "If I start with a given volume, then, I think, I will obtain a pyramid with the greatest volume and the greatest surface area. One is the prerequisite for the other." The students were invited to verify Blerta's statement. If you consider all our paper models, do you find it true that the one with the greatest volume has the greatest surface area? At this point, we quickly realised that we had reached the limit of what was possible at our level. The question seemed more appropriate for a higher secondary school task.

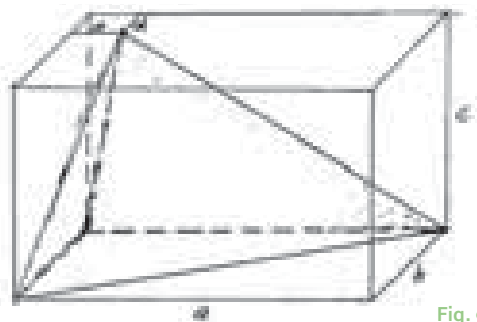

Fig. 97: Josua's sketch

### Example 4: An inscribed pyramid

The students had been asked to inscribe pyramids into cuboids and to perform related calculations. In his journal, Josua noted that he wanted to calculate the volume and the surface area of the pyramid drawn (Fig. 97). The volume posed no problem, but his calculations soon came to an end when he tried to work out the surface area.

I picked up his attempt and created a worksheet that allowed the students to calculate all parts of the surface area separately (Fig. 98). The area of the triangle ACP (P being a point in the rectangle EFGH) posed a major problem.

We had the lengths of the three sides, but it seemed impossible to calculate the height. We found Heron's theorem and with the help of Heron's formula, we eventually managed to solve Josua's question. Josua himself even managed to find a solution that invoked the use of similar triangles.

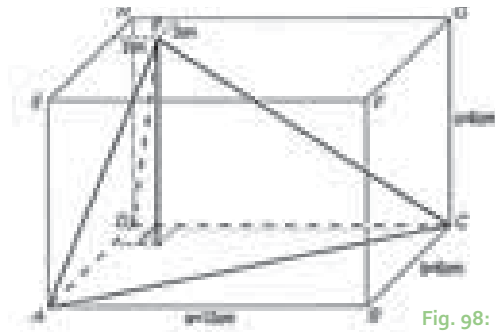

Fig. 98: Diagram from worksheet

Heron's theorem is not normally part of our curriculum. For me, the use of this particular formula demonstrates an important aspect of learning, namely that we should not simply learn particular theorems when and because they are listed in our curriculum but when they become an integral requirement to find a solution. For the students, it was a great success to discover that there was a formula that solved our problem elegantly.

### The aim of the journey

Our goal was to find out who among the students had created the greatest possible pyramid from a given sheet of A3 paper. We agreed that we needed to consider several categories. This, in turn, led to a variety of tasks, which – under normal circumstances and given in a text book – would be perceived as laborious or outright boring. However, because the students wanted to determine the winner, they went about it with great enthusiasm.

The results were recorded in a table (Fig. 99).

Rangliste Pyramide										
Wahr	Länge l (mm) Seite a	Breite b (mm) Höhe h	Körperhöhe H <sub>K</sub> (mm)	Dreieckfläche h 1 (mm <sup>2</sup> )	Dreieckfläche h 2 (mm <sup>2</sup> )	Dreieckfläche G (mm <sup>2</sup> )	Dreieckfläche A 1 (mm <sup>2</sup> )	Dreieckfläche A 2 (mm <sup>2</sup> )	Oberfläche S (mm <sup>2</sup> )	Volumen V (mm <sup>3</sup> )
1 Adeline	160	160	60	100	100	25600	8000	8000	57600	612000
2 Anman	132	132	121,2	138	138	17424	9108	9108	53858	703829
3 Berta	170	170	84,7	120	120	28900	10200	10200	39100	618843
4 Cedric	160	160	60	100	100	25600	8000	8000	57600	612000
5 Christian	150	150	108,2	130	130	22500	9750	9750	61500	796500
6 Josua	100	100	88,6	100	100	10000	5000	5000	30000	288668
7 Kristina	160	160	120,8	140	140	19600	7000	7000	47600	5484174

Fig. 99: Ranking (part of the table)

Thus, we reached our goal and during our journey touched many important (and to the curriculum relative) aspects. At the same time, the tasks gripped both students and teacher alike.

## Looking back

With this journey into the realm of pyramids, I would like to show that we touched nearly all aspects as set down in the curriculum even without the use of a text book. Many questions turned out to be natural questions that the students asked themselves. The crucial factor here was the first task, which kept us busy and motivated throughout the whole journey. The following table shows the topics we dealt with in comparison to the topics scheduled in our text book. The table also lists topics that became part of our investigation but would not have been touched if we had used the book.

Topics and exercises dealt with in the text collections that were copied for all students (No use of a text book):	
Topics in our book	Additionally treated topics
Two nets of a square-based right pyramid	<ul style="list-style-type: none"><li>▪ all possible nets</li><li>▪ finding congruent nets</li><li>▪ discussing the definition</li></ul>
Building a square-based right pyramid	<ul style="list-style-type: none"><li>▪ building an oblique pyramid</li><li>▪ building a tetrahedron</li></ul>
Drawing a pyramid in 3D	
Calculating surface area, volume, height, side length, slant height	<ul style="list-style-type: none"><li>▪ calculating these values for our own models</li></ul>
Constructing lengths given in a 3D diagram in their actual size	
Constructing areas given in a 3D diagram in their actual size	
Calculating the volume and the size of a four-sided pyramid inscribed into a cube or cuboid	<ul style="list-style-type: none"><li>▪ similar exercises prepared by the students</li><li>▪ similar exercises relating to a three-sided oblique pyramid</li></ul>

The above table illustrates that we covered nearly all aspects as set down by our curriculum. One topic, compound shapes, had been left untreated, but I was able to use the question from the text book as an exam question.

## Summary

I have always considered the chapter in our geometry book on pyramids as a little dull. Through the *dialogic learning* approach, the discussion of this topic has become lively and, in fact, gripping. Even I as a teacher have learnt a lot. More importantly, and once again, I have noticed with pleasure how willingly students contribute with innumerable excellent ideas and questions. The reading of their journals often surpassed the fascination of reading a crime novel and was as stimulating as subject literature. Motivation among my students was perceived to be extremely high. Some of the students couldn't let go, continued working at home and came back with wonderful ideas.

A particular challenge the teacher faces within the framework of this model is the fact that lessons cannot (indeed need not and should not) be planned weeks in advance. Sometimes, only the reading of the journals induces a new idea that is worth pursuing as a task the next day. Now and then something exciting comes up in the middle of a task being worked on. If it merits closer inspection, then this could be the next task.

Overall, I recommend that the teacher be highly flexible and that he particularly believe in the students' abilities. A little more trust in their skills than is today sadly often the case will be more than generously rewarded.

## 4.7 Fibonacci in Thuringia/Germany – Inquiry-based learning in interdisciplinary lessons

*Jörg Triebel*



Fig. 100: Pupil work on the subject of ETERNAL

The Thuringian teachers developed many examples of inquiry-based lessons during the Fibonacci project. As well as lesson units dealing with topics that were purely mathematical, interdisciplinary examples also occurred in cooperation with teachers from the physics, biology and chemistry areas.

The lesson unit on the subject of "The eternal – fascinating connections between nature, art and mathematics" that is described in the following shows the results of such interdisciplinary collaboration.



Fig. 101: The Fibonacci sequence in nature

Two pupils from the Goethe Grammar School in Weimar expressed their opinions at the end of the project:

*We dealt with the question of what eternity is, and how we can understand it. In order to do this, we learned a great deal about mathematics and biology, and then made copies of pictures that attempt to comprehend the concept of eternity. We came across one thing time and time again: The Fibonacci sequence. Many of you may be familiar with this from the Dan Brown book "The Da Vinci Code". The Fibonacci sequence is an expression of eternity, since the numbers become consecutively bigger and the sequence is endless.*

During the project the pupils solved the famous “rabbit problem” and dealt with other tasks concerning endless number sequences. They learned about applications for the Fibonacci sequence in art and architecture and the meaning of the *golden section*, e.g. in the famous picture by Leonardo da Vinci “The Vitruvian Man”. The pentagram also provided many opportunities for geometrical and historical research.

The pupils also discovered connections with the Fibonacci sequence in plants and animals and even in people during the biological part of the project work. The variety of discoveries surprised all of the pupils, since these connections were completely new to them.

In the artistic part, the young people creatively implemented their new knowledge about the Fibonacci sequence in their own pictures. Enthusiastic feedback was provided upon completion of the project: *“We all enjoyed being able to see the factual formulas and numbers in nature. Ultimately, we allowed both the Fibonacci sequence and the spiral to flow into our pictures.”*

Some examples show the wide variety of topics that were dealt with.

### 4.7.1 Spirals

- The flowers and fruit of some plants are in the form of spirals. The number of spirals is always a Fibonacci number, and in the case of fir and pine cones and the romanesco broccoli this numbers are 13 and 21.
- The arrangement of the Egyptian pyramids of Giza corresponds to a giant spiral, and the golden number phi can be calculated using the Orion constellation.



Fig. 102: Pine cones

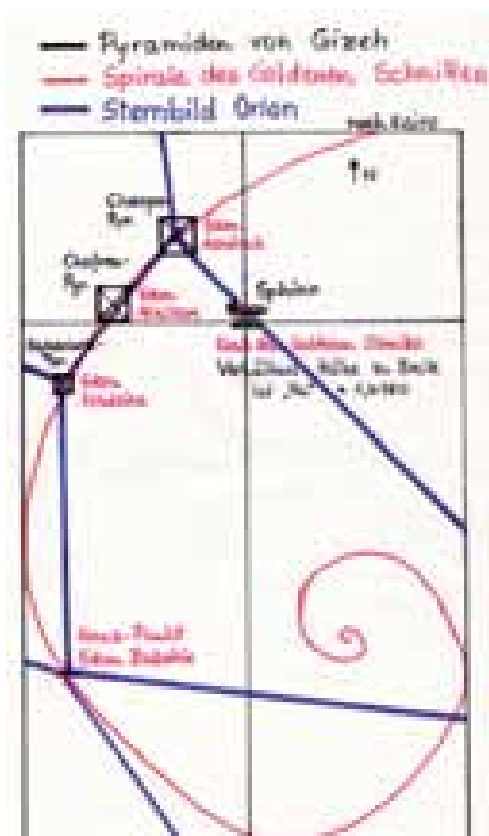

Fig. 103: Sunflower

Fig. 104: Pupil work on the location of the pyramids of Giza and the Orion constellation.



### 4.7.2 The golden section

- The growth of trees and the arrangement of the branches can also be described using Fibonacci numbers, and provide proportions that correspond with the golden section.
- Proportions of the human body in the golden section:  
The length ratio of lower arm to the hand and the length ratios of the phalanges are close to the golden section. Many other length ratios in the human body also correspond to the golden section.



Fig. 105: Skeleton of a human hand

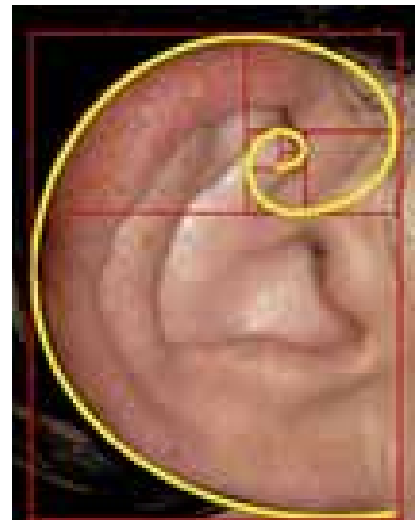

Fig. 106: The human ear

### 4.7.3 The golden angle

The golden angle ( $\phi \approx 137.50$ ) is the result of dividing the full angle by the golden section.

- Nature arranges leaves using the golden angle:  
The leaves are given new positions time and time again by means of repeated rotation around the golden angle. The irrationality of the golden number does not permit any exact coverage, meaning that each leaf can be provided with sufficient light and nourishment.
- The angle that the branches and the leaves form with the stem frequently corresponds to the golden angle.



Fig. 107: Dahlia blossom



Fig. 108: Sunflower

▪ **Seeds in inflorescence**

The angle between the architecturally neighbouring leaves or seeds in relation to the plant axis is the golden angle.



Fig. 109: Fern leaf with golden angle

### 4.7.4 Fibonacci numbers

The number of petals in many plants corresponds to a Fibonacci number. Some examples:

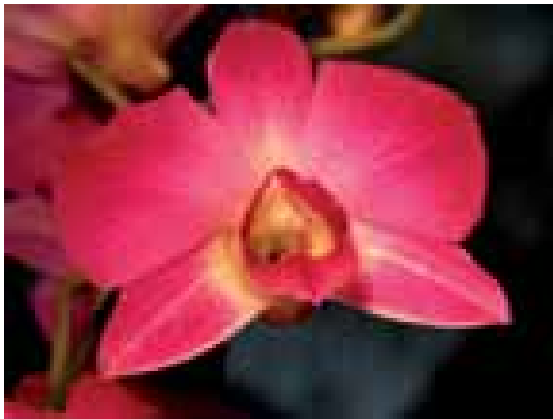

Fig. 110: Orchid with 5 petals



Fig. 111: Cosmos plant with 8 petals

The passion flower (passiflora) has some particularly interesting associations with Fibonacci numbers:

- It has five sepals and five petals
- 55 radial filaments,
- five anthers,
- three stigmas

Since this pupil project was so successful, it was introduced to interested teachers within the scope of several training courses. 130 teachers were able to obtain suggestions for their own lessons at two national conferences.

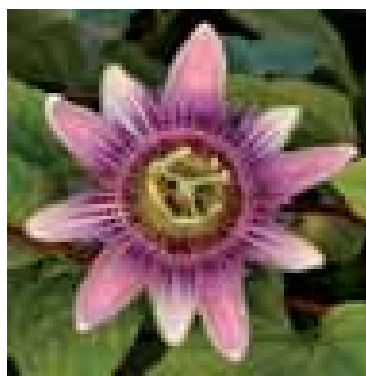

Fig. 112: Blossom of a passion flower

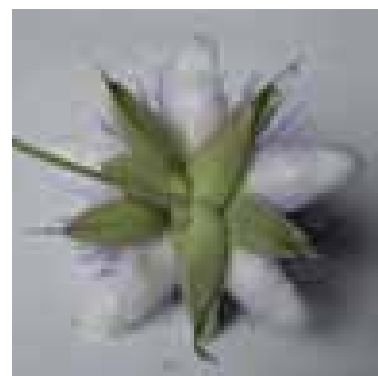

Fig. 113: Blossom of a passion flower (reverse side)

Workshops in which teachers introduce successful example lessons and collaborate to develop them further have generally proven to be extremely successful. The positive feedback that has been received is confirmation that this training is a suitable instrument for the further development of the lesson.

## References

- 1 Baptist, P.: Towards New Teaching in Mathematics, Conclusions from the SINUS and SINUS-Transfer Pilot Studies. Fibonacci Starting Package, Bayreuth 2010  
<http://fibonacci-project.eu/resources> (last visited 12/18/2012)
- 2 Dubs, R.: Konstruktivismus, Einige Überlegungen aus der Sicht der Unterrichtsgestaltung. Zeitschrift für Pädagogik, 41/6, 1995, pp. 889-903
- 3 Gallin, P. and U. Ruf: Dialogisches Lernen in Sprache und Mathematik. Seelze: Kallmeyer 2011
- 4 Green, N. and K. Green: Kooperatives Lernen im Klassenraum und im Kollegium. Seelze: Kallmeyer 2005
- 5 Haberlandt, K.: Cognitive Psychology. Allyn and Bacon, Boston 1997
- 6 Ihn-Huber, P.: Windows on the Hundreds Chart. In: Ulm, V. (ed.): Inquiry-Based Mathematics Education for Gifted Children in Primary School. Fibonacci Publications, Augsburg 2011  
<http://fibonacci-project.eu/resources> (last visited 12/18/2012)
- 7 Ihn-Huber, P.: Quadruples. In: Ihn-Huber, P. and R. Dolenc-Petz (eds.): Supporting Geometric Competences. Fibonacci Publications, Augsburg 2012  
<http://fibonacci-project.eu/resources> (last visited 12/18/2012)
- 8 Krauthausen, G. and P. Scherer: Umgang mit Heterogenität, Natürliche Differenzierung im Mathematikunterricht der Grundschule, Handreichung des Programms "SINUS an Grundschulen". Leibniz-Institut für die Pädagogik der Naturwissenschaften und Mathematik, Kiel 2010
- 9 Reinmann-Rothmeier, G. and H. Mandl: Wissensvermittlung. In: Klix, F. and H. Spada (eds.): Enzyklopädie der Psychologie. C/II/6. Hogrefe, Göttingen 1998, pp. 457-500
- 10 Ulm, V.: Teaching Mathematics – Opening up Individual Paths to Learning. In: Baptist, Peter, Carsten Miller, and Dagmar Raab (eds.): Towards New Teaching in Mathematics, Sinus international, Issue 3, 2011  
<http://sinus-international.net> (last visited 12/18/2012)
- 11 Wittmann, E.: Mathematics Education as a 'Design Science'. Educational Studies in Mathematics, 29, 1995, pp. 355-374
- 12 Wittmann, E. Ch.: Developing Mathematics Education is a Systemic Process. Educational Studies in Mathematics, 48, 2001, pp. 1-20
- 13 Wittmann, E.Ch.: Natürliche Differenzierung im Mathematikunterricht der Grundschule – vom Fach aus. In: Hanke, P. et al.: Anspruchsvolles Fördern in der Grundschule. Münster: Zentrum für Lehrerbildung 2010, pp. 63 - 78
- 14 Comenius, John Amos: The Great Didactic. Translated into English and edited with biographical, historical and critical introductions by M. W. Keatinge, Russell & Russell, New York 1967  
<http://studentzone.roehampton.ac.uk/library/digital-collection/froebel-archive/great-didactic/index.html> (last visited 10/15/2012)
- 15 Dewey, John: Logic: The Theory of Inquiry. Holt, Rinehart and Winston, New York 1938
- 16 Brown, Matthew J.: John Dewey's Logic of Science. HOPOS: The Journal of the International Society for the History of Philosophy of Science, Vol. 2, No. 2 (Fall 2012), pp. 258-306

- 17 Research Institute of Education in Prague: Ramcovy vzdelavaci program pro gymnazia [Framework Education Programme for Grammar Schools], 2007  
[http://www.vuppraha.cz/wp-content/uploads/2009/12/RVPG-2007-07\\_final.pdf](http://www.vuppraha.cz/wp-content/uploads/2009/12/RVPG-2007-07_final.pdf) (last visited 10/15/2012)
- 18 Research Institute of Education in Prague: Ramcovy vzdelavaci program pro zakladni vzdelavani [Framework Education Programme for Elementary Education], 2007  
[http://www.vuppraha.cz/wp-content/uploads/2009/12/RVPZV\\_2007-07.pdf](http://www.vuppraha.cz/wp-content/uploads/2009/12/RVPZV_2007-07.pdf) (last visited 10/15/2012)
- 19 Samkova, L.: IBSME in the Czech Republic. Fibonacci Project European Conference, Leicester 2012  
<http://fibonacci.uni-bayreuth.de/resources/events/leicester-conference-2012/informal-proceedings.html> (last visited 10/15/2012)
- 20 Samkova, L.: Fibonacci TC1 Budweis Web, 2012  
<http://www.pf.jcu.cz/stru/katedry/m/fibo.html> (last visited 10/15/2012)
- 21 Dynamic worksheet. <http://www.pf.jcu.cz/stru/katedry/m/Fibo/Lud.html> (last visited 10/15/2012)
- 22 Dewey, J.D.: How We Think. D.C. Heath, Boston 1910, p. 224
- 23 Hašek, R. and V. Petrášková: A Way to Improve Financial Literacy of Future Teachers. In: Bianco, Tamara and Volker Ulm (eds.): Mathematics Education with Technology - Experiences in Europe. Augsburg 2010, pp. 199 - 218.
- 24 Hašek, R. and V. Petrášková: Issue of Financial Capability. The International Journal for Technology in Mathematics Education. Research Information Ltd., Burnham, UK. Volume 17, Number 4, 2010, pp. 183 - 190
- 25 Hejný, M. and F. Kuřina: Dítě, škola a matematika. 2. vyd. Portál s.r.o., Praha 2009, p. 240
- 26 Kratochvílová, J. and K. Černá: Projektová výuka. Portál Školní vzdělávací programy. Pedagogická fakulta, Masarykova univerzita 2006 [cit. 2010-10-30]  
<http://svp.muni.cz/ukazat.php?docId=495> (last visited 10/15/2012)
- 27 Maňák, J. and V. Švec: Výukové metody. Brno: Paido – edice pedagogické literatury 2003, p. 219
- 28 MEYS CR.: Framework Education Programme for Secondary General Education (Grammar Schools). Praha: Ministry of education, youth and sports of the Czech Republic 2007 [cit. 2012-08-07]  
[http://www.vuppraha.cz/wp-content/uploads/2009/12/RVP\\_G-anj.pdf](http://www.vuppraha.cz/wp-content/uploads/2009/12/RVP_G-anj.pdf) (last visited 10/15/2012)
- 29 Okoň, W.: K základům problémového učení. 1. vyd. Praha: SPN 1966, p. 222
- 30 Petrášková, V.: Pre service teachers' financial literacy. In: Tso, T.Y. (ed.): Proceedings of the 36th Conference of the International Group for the Psychology of Mathematics Education, Vol.4, Taipei, Taiwan 2012, p. 314
- 31 Petrášková, V. and R. Hašek: Financial education demands concerning teacher training. Acta Didactica Universitatis Comenianae- Mathematics, Issue 12, 2012
- 32 Projekt Fibonacci: Fibonacci TC1 Budweis Web. České Budějovice: University of South Bohemia, Faculty of Education, Department of Mathematics 2012 [cit. 2012-08-07]  
<http://www.pf.jcu.cz/stru/katedry/m/envieng.html> (last visited 10/15/2012)
- 33 Piaget, J.: The child's conception of time. Ballentine, New York 1969
- 34 Burny, E., M. Valcke, and A. Desoete: Towards an Agenda for Studying Learning and Instruction Focusing on Time-Related Competences in Children. Educational Studies 35(5), 1969, pp. 481-492

- 35 Fibonacci project resources  
<http://www.math.bas.bg/omi/Fibonacci/archive.htm> (last visited August 22, 2012)
- 36 Chehlarova, T.: Problems with a clock for developing the space intelligence. *Primary Education Journal*, 2, 2009, pp. 8–22 (in Bulgarian)
- 37 Chehlarova, T.: Imprecise clocks  
[http://www.math.bas.bg/omi/docs/clock\\_nepравilni\\_4klas\\_BG/index.htm](http://www.math.bas.bg/omi/docs/clock_nepравilni_4klas_BG/index.htm) (last visited August 22, 2012)
- 38 Sendov, Bl.: Education for an Information Age. *Impact of Science on Society*, v37 n2, 1987, pp. 193-201
- 39 Sendov, Bl.: Towards global wisdom in the era of digitalization and communication. *Prospects*, 27, n3, 1997, pp. 415-426
- 40 Sendov B., R. Filimonov, and D. Dicheva: A System for Teaching Plane Geometry. *Proceedings of the Second International Conference "Children in the Information Age"*, Sofia 1987, pp. 215-226
- 41 Sendov, B. and D. Dicheva: A Mathematical Laboratory in Logo Style. In: Lovis, F. and E.D.Tagg (eds.): *Computers in Education – Proceedings of the IFIP TC3 European Conference on Computers in Education (ECCE'88)*, Lausanne, Switzerland, North Holland 1988, pp. 213-223
- 42 Sendov, B. and E. Sendova: To Discover America of Yours: Learning Mathematics in a Logo Based Environment. In: Calabrese, E. (ed.): *Proceedings of the Third European Logo Conference*, Parma, Italy, 1991, pp. 343 - 354
- 43 Sendov, B. and E. Sendova: Getting into the Habit of Creative Thinking in a Computer Microworld: Plane Geometry System. In: Graf, K.-D., N. Malara, N. Zehavi, and J. Ziegenbalg (eds): *Technology in the Service of the Mathematics Curriculum - Proceedings of WG 17 at ICME-7, the 7th International Congress on Mathematics Education*, Quebec 1992, pp. 191-196
- 44 Sendova, E.: Assisting the art of discovery at school age – a Bulgarian experience. 2011  
<http://www.worldtal.org/libros/Bulgaria.pdf> (last visited October 6, 2012)
- 45 Sendova, E.: Enhancing the Scientist into the Pupil: A Computer Environment supporting Discoveries in the Classroom. In: Aiken, R. (ed.): *Education and Society, Information Processing 92*, vol. 2, Elsevier Science Publishers B.V., North-Holland 1992, pp. 174-180
- 46 Sendova, E. and B. Sendov: Columbus, Da Vinci or Prometheus: A New Role for the Mathematics Teacher in a Computer Environment. *Journal of Technology and Teacher Education*, vol. 1 (2), 1993, pp. 209-215
- 47 Kolcheva, M. and E. Sendova: Learning Rather Than Being Taught: A new Style of Studying Plane Geometry. In: Knierzinger, A. and M. Moser (eds.): "Informatics and Changes in learning", *Proceedings of the IFIP Open Conference*, Gmunden, Austria, Session 2.1, 1993, pp. 19-22
- 48 Sendov, B. and E. Sendova: East or West - GEOMLAND is BEST, or Does the Answer Depend on the Angle? In: diSessa, A.A., C. Hoyles and R. Noss (eds.): *Computers and Exploratory Learning*, NATO ASI Series, Series F; Computer and Systems Sciences, Vol. 146, Springer - Verlag, Berlin 1995, pp. 59 – 79
- 49 Nikolova, I. and E. Sendova: Logo in the Curriculum for Future Teachers: A Project-based Approach. In: O Duill, M. (ed.): *Building Logo into the School Curriculum - Eurologo Proceedings & Outcome*, Fifth European Logo Conference, affiliated to IFIP WCCE/95, 1995, pp. 10 – 17
- 50 Bianco, T.: Quality Standards for Learning Environments – an Overview. *Universität Augsburg, Arbeitsbericht 23*, 2009, [http://opus.bibliothek.uni-augsburg.de/opus4/files/1271/imb\\_Arbeitsbericht\\_23.pdf](http://opus.bibliothek.uni-augsburg.de/opus4/files/1271/imb_Arbeitsbericht_23.pdf) (last visited November 12, 2012)

- 51 Kenderov, P.: Innovations in mathematics education: European projects InnoMathEd and Fibonacci. Proceedings of the 39th Spring Conference of the Union of Bulgarian Mathematicians, 2010, pp. 63-72 (in Bulgarian).
- 52 Chehlarova, T., D. Dimkova, P. Kenderov and E. Sendova: Seeing the innovations as an opportunity, not a threat: lessons from the InnoMathEd European project. Spring Conference of the Union of the Bulgarian Mathematicians and Informaticians, Borovets 2011, pp. 347-355
- 53 Kenderov, P. and E. Sendova: Enhancing the inquiry based mathematics education. UNESCO International Workshop: Re-designing Institutional Policies and Practices to Enhance the Quality of Teaching through Innovative Use of Digital Technologies, Sofia 2011, pp. 56-70
- 54 Dimkova, D.: Reflection in line  
[http://www.math.bas.bg/omi/docs/Reflection\\_in\\_line\\_EN/Start\\_Reflection.html](http://www.math.bas.bg/omi/docs/Reflection_in_line_EN/Start_Reflection.html)  
 (last visited August 25, 2012)
- 55 Chehlarova, T.: Compositions of congruencies  
[http://www.math.bas.bg/omi/docs/Proizvedenie\\_na\\_ednakvostiBG/index.htm](http://www.math.bas.bg/omi/docs/Proizvedenie_na_ednakvostiBG/index.htm)  
 (last visited August 25, 2012)
- 56 Chehlarova, T. and E. Sendova: Stimulating different intelligences in a congruence context. In: Proceedings for Constructionism 2010. The 12th EuroLogo conference. Paris, France 2010
- 57 Chehlarova, T.: Congruencies via reflections.  
[http://www.math.bas.bg/omi/docs/Ednakvosti\\_chres\\_simm2\\_BG/index.htm](http://www.math.bas.bg/omi/docs/Ednakvosti_chres_simm2_BG/index.htm) ( last visited August 25, 2012)
- 58 Blaho, A. and I. Kalas: Learning by developing. Logotron 1998, pp. 112-136
- 59 Clayson, J.: Visual Modeling with Logo. MIT Press 1988, pp. 15-126
- 60 Sendova, E. and S. Grkovska: Visual Modeling as a motivation for studying mathematics and art. In: Gregorczyk, G. et al (eds.): Proceedings, EUROLOGO'2005, pp. 12-23
- 61 Kovatcheva, E.: Tuning the ICT instruments for Harmony in Mathematics and Arts. Working Joint IFIP Conference: WG3.1 Secondary Education, WG3.5 Primary Education Informatics, Mathematics, and ICT: a 'golden triangle', Boston, MA 2007
- 62 Chehlarova, T., E. Sendova, and Stefanova: Dynamic tessellations in support of the inquiry-based learning of mathematics and arts. In: Kynigos, C., J. Clayson and N. Yiannoutsou(eds.): Theory, Practice and Impact - Proceedings of Constructionism 2012, Athens 2012, pp. 570-574
- 63 Schattschneider, D.: The Mathematical Side of M.C. Escher. In: Pitici, M. (ed.): The Best writings on Mathematics, Princeton University Press 2011, pp. 121-149
- 64 Kaplan, C.: Escherization.  
<http://www.cgl.uwaterloo.ca/~csk/projects/escherization/> (last visited September, 2012)
- 65 Ruf, Urs, Stefan Keller, and Felix Winter (eds.): Besser lernen im Dialog, Dialogisches Lernen in der Unterrichtspraxis. Klett/Kallmeyer Verlag 2008
- 66 Anna Susanne Steinweg: Zur Entwicklung des Zahlenmusterverständnisses bei Kindern: Epistemologisch-pädagogische Grundlegung. [On the development of childrens' comprehension of number patterns: basics in pedagogy and epistemology], Lit-Verlag Münster 2001
- 67 Madipedia Index  
[http://www.madipedia.org/index.php/Kategorie:Dissertationen\\_2000](http://www.madipedia.org/index.php/Kategorie:Dissertationen_2000) (last visited 10/15/2012)

- 68 Ryan, Richard M. and Edward L. Deci: Self-Determination Theory and the Facilitation of Intrinsic Motivation. Social Development and Well-Being. In: American Psychologist, 55 (200), 2000
- 69 Stephan, Holger: Zahlenfolgen (number sequences). Weierstraß-Institut für Angewandte Analysis und Stochastik, Berlin 2001  
<http://www.wias-berlin.de/people/stephan/folgen.pdf> (last visited 10/17/2012)

## Photo Credits

- Fig. 1: Photo: Volker Ulm, Augsburg, Germany
- Fig. 3: Dam of Orlik reservoir, created by Honza Groh, Wikimedia Commons under license CC BY 3.0
- Fig. 34: Calouste Gulbenkian Museum, Turk pottery with Cypress tree decorations, Iznik, second Half of the 16th Century, Ottoman Periods, created by deror avi, Wikimedia Commons under license CC BY 3.0
- Fig. 35: Gentzrode near Neuruppin, rosette in the granary, created by ONAR, Wikimedia Commons under license CC BY 3.0
- Fig. 36: Ebrach Abbey, Church, Rose window, public domain
- Fig. 37: German Hapsichord - detail - restorer Georg Ott, created by PPraetorius, Wikimedia Commons under license CC BY 3.0
- Fig. 66 - 70: Photos: Evgenia Sendova, Sofia, Bulgaria
- Fig. 88 – 90: Photos: Markus Jetzer-Caversaccio, Schlieren, Switzerland
- Fig. 100 – 109, 111: Photos: Andrea Müller, Bad Berka, Germany
- Fig. 110, 113: Photos: Dagmar Raab, Bayreuth, Germany
- Fig. 112: Passiflora × belotij, created by Tomas Castelazo, Wikimedia Commons under license CC-BY-SA-2.5

## Translation

- Section 4.6 Mike Rohr, Zurich, Switzerland
- Section 4.7 Spracheninstitut Bamberg, Germany





# 5 IBME in Teacher Education

---

## 5.1 In-service teacher training in the Czech Republic

*Libuse Samkova*

In-service training is not a compulsory activity in the Czech Republic; teachers do not need to attend any seminars or workshops to advance in their careers. In extreme cases, pre-service university courses are the last instruction a teacher receives.

Our department of mathematics is well aware of this very unsatisfactory situation: Mathematics itself may not change, but the teacher does (as he professionally matures over time) – and so does classroom environment (pupils' needs change, curricula are modified, new classroom equipment appears, computers and educational software are constantly improving). Therefore, teachers need to take part in continuing education and training to stay on top of the current developments in mathematics education.

That is the reason why our department maintains on-going relationships (also on a long-term basis) with our graduates and with other mathematics teachers interested in in-service teacher training.

Every year we organise one or two 4-day intensive training courses. In these training sessions we acquaint mathematics teachers with new trends, train them in using computers in teaching and help them cope with the growing demands of the school curriculum. Recently we put emphasis on the use of GeoGebra in teaching and on implementation of inquiry based methods into mathematics education.

Each course is intended for about 30 teachers; some of them are new to the course, and roughly half of the participants take part on a regular basis. These regular participants have become a part of the training team: They present their schoolwork to other colleagues and share their teaching experiences. Broad discussions are an essential part of our teacher trainings.

## 5.2 How to encourage teachers to participate in IBME activities

*Libuse Samkova*

Since the IBME way of teaching is demanding for teachers, we need to motivate them positively, stimulate their IBME activities, encourage them in their work, and offer them new ideas and approaches.

We present them new ideas for implementing IBME into teaching, acquaint them with ready-to-use learning environments, and help them prepare their own IBME materials – not just at teacher trainings, but also during the whole school year (through personal or e-mail consultations).

Sometimes we offer them an atmospheric impulse. For example, in the form of mathematically tuned video promotion. These videos focus on mathematics around us in our everyday lives. They monitor the occurrence of mathematical shapes in nature, architecture, art, mechanics, geomorphology, microcosmos, etc. Some instances are obvious, while others are thought provoking.

One of the videos is called *Regular polygons around us*. It contains images of various traffic signs, buildings, technical equipment, animals, flowers, coins, magnified details of snowflakes or eyes – in other words, familiar everyday objects (Fig. 1 – 20):



Fig. 1: Stop sign



Fig. 2: Carniolan honey bee (*Apis mellifera carnica*)

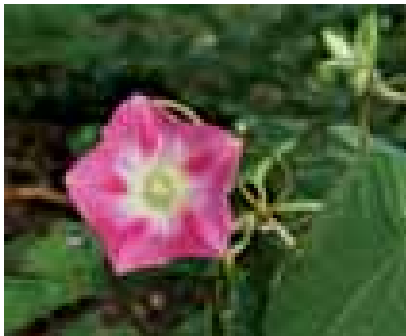

Fig. 3: Morning glory (*Ipomoea purpurea*)

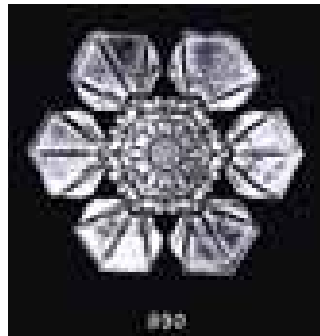

Fig.4: Snowflake



Fig. 5: Norwegian road sign 154

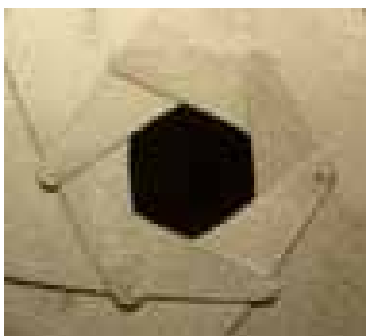

Fig. 6: A six-blade iris from a camera lens



Fig. 7: Chrysler's Pentastar logo

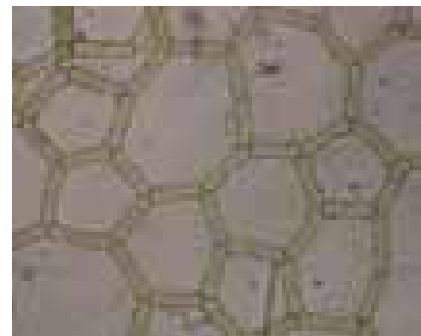

Fig. 8: Hydrodictyon  
(*Chlorophyceae, Chlorococcales*)



Fig. 9: Fort Jefferson at the Dry Tortugas



Fig. 10: Australian kangaroo warning road sign



Fig. 11: Reverse of a 1942 George VI U.K. threepence



Fig. 12: Baptistry of Firenze, Italy



Fig. 13: Official match ball for the 1974 FIFA World Cup Germany

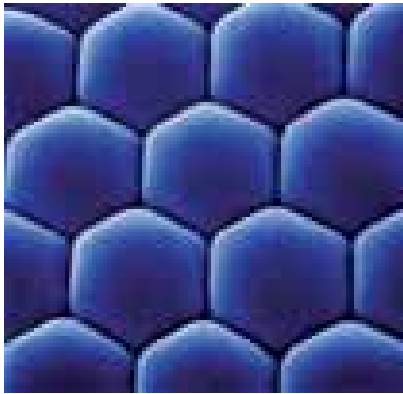

Fig. 14: Ommatidia of an eye of Antarctic krill



Fig. 15: Rime frost on both ends of a "capped column" snowflake

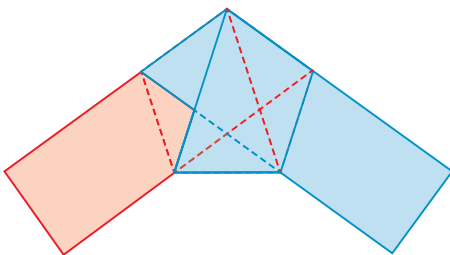

Fig. 16: Paper folded regular pentagon



Fig. 17: Allen screws (Inbus)

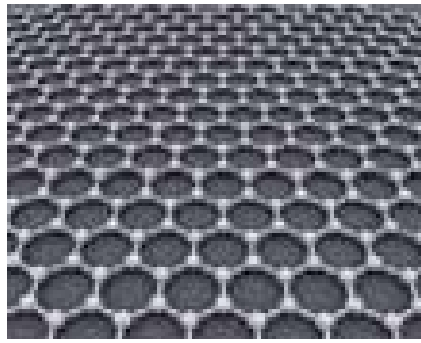

Fig. 18: Crystalline structure of graphene

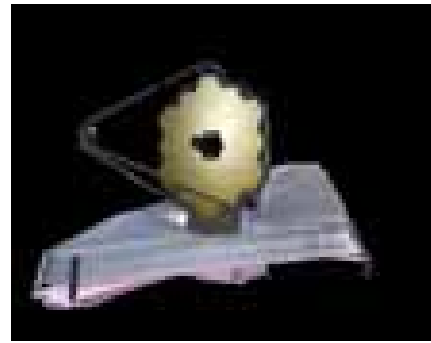

Fig. 19: James Webb Space Telescope



Fig.20: Giant's Causeway Co. Antrim,  
Northern Ireland

Such video presentations encourage teachers to look for new approaches to their mathematics lessons and to suggest different places where mathematics can be found. They offer topics for discussion on the importance of mathematics and on the presence of mathematics in everyday life.

They even inspire some teachers to create similar presentations on various mathematical topics. They can also invite children to cooperate on a similar project, like taking photos of mathematics around us and creating a presentation themselves. This approach is very effective in improving students' awareness and understanding of mathematics.

## 5.3 The specifics of the teacher education within the Fibonacci project in Bulgaria

*Evgenia Sendova, Toni Chehlarova*

*Teachers should not ask the questions but kids should ask the questions....*

*The ideas should be born in the students' mind and the teacher should act as a midwife.*

*George Polya (1887 - 1985)*

The Inquiry Based Mathematics Education (IBME) in the frame of the Fibonacci project has been promoted in Bulgaria at two levels - nationally and locally, in major regional centres<sup>1</sup>. At national level the promotion instruments were workshops, seminars and special sections of the national conferences organised by the Union of Bulgarian Mathematicians. At a local level IBME was promoted and supported by multiple training and presentation sessions organised in fifteen Bulgarian regions with the help of the Local Boards.

### 5.3.1 Teacher training courses promoting a new role for the teachers

The specifics of the teacher training courses were the variety of the audience. The school principals would often form groups of teachers from the primary and secondary school, teachers in mathematics, informatics, ICT, and sometimes even in science, arts, and history so as to gain a critical mass of teachers able to implement the inquiry based learning by means of dynamic computer environments. Thus the teacher educators had to introduce relatively new dynamic software environments (*GeoGebra*, *Geonext*, *Elica* applications for 3D explorations) for a couple of days in the context of dynamic scenarios developed by the Bulgarian Fibonacci team<sup>2</sup> in harmony with the curriculum (but not limited to it) demonstrating at the same time the inquiry-based teaching/learning process. This means that they had to experience jointly the phases of search, experiments, formulating conjectures, checking and verifying them, and in some cases – providing rigorous proofs.

The participating teachers experienced the potential of the learning environments specially designed (i) to support a joint work among teachers and students acting like a research team in which the teacher acts as a discovery-guide; (ii) to encourage students to find their own learning paths according to their interests and potential, and (iii) to build the knowledge in a cross-disciplinary context, especially integrating mathematics with ICT, natural science and art (for details see also [section 3.2](#)).

In order to grasp better the specifics of the IBME the teachers were encouraged to enter the role of their students and to explore the dynamic software environments on their own. Thus, even teachers with relatively modest technical skills could gain self-confidence and show promising results<sup>3</sup>.

Furthermore, they could experience the profit of working in teams integrating people with different level of technical skills, various interests and expertise, still sharing the same enthusiasm of creating an exploratory spirit in their class settings.

The variety of the audience stimulated the lecturers to reveal a broad spectrum of the potential of the dynamic software - from typical geometry constructions, to modeling rotational objects and tessellation in the style of Escher<sup>3, 4</sup> (see also [sections 3.2 and 4.4](#)).

In addition to the teacher education courses the first phase of the Fibonacci project embraced the following activities:

- Follow-up visits to check the progress of the teachers with using dynamic computer environments;
- Development and providing an open access to more than 50 dynamic scenarios appropriate for implementing IBME in 1-12 grades;
- Launching a competition among teachers for developing mathematics modules based on dynamic software;
- Stimulating the submission of articles in specialised journals and international conferences;
- Development of the first issues of a series of dynamic textbooks for the junior high school;
- Organising a bi-weekly Fibonacci Seminar on the premises of IMI-BAS;
- Stimulating the work of teachers working with mathematically gifted high-school students on research projects;
- Organising invitational seminars and workshops for sharing the best IBME practices.

### 5.3.2 The follow-up events and the international component

The workshops and the seminars following the training courses were organised to check the progress of the teachers in acquiring the skills necessary to implement dynamic computer environments in a class setting. At these events the teachers presented and defended projects developed individually or in a team on a topic currently taught by them.

The first impressions of the Fibonacci team were that the prevailing part of the teachers having attended the short term training were still seeing the dynamic software as a means for visualisation of mathematical facts rather than for organising experiments and explorations, for discovering patterns, for making conjectures.

Feeling comfortable with the use of dynamic software is an important step towards making the inquiry-based approach a natural component of the learning process. However, changing the style of teaching so that the teachers could accept the role of a partner in a research process requires ongoing efforts on behalf of the teacher educators. These efforts include preparing a good ground for exploration activities including re-formulation of some classical problems so as to *stimulate acts*. Furthermore, we should not stop there – “you do, you understand” says the old Chinese proverb. That is true but our goal is to extend it to “you explore, you invent”... In some cases the teachers would react with: *O-o-h, the inspectors would not be happy with this "waste of time" – we have to cover the curriculum, the students have to pass the tests, etc. ...* And they would be right if we accept that education is about *knowing the right answers ...*

Thus, the next step (still a challenge for us as promoters of the inquiry-based learning) is to provide on-going support to the teachers in applying in class the full potential of the dynamic mathematics software in harmony with this learning style.

To meet this goal we have been organising in the frames of the Fibonacci project open meetings/seminars twice a month discussing various strategies of supporting teachers in their efforts. The proposed strategies include maintaining a forum on the project using various platforms for sharing the best IBME practices of teachers, visiting the Fibonacci project schools, updating and enriching the repository of dynamic learning environments, writing and translating electronic textbooks facilitating the disseminations of the Fibonacci project ideas.

The experience of the University of Bayreuth (our Fibonacci Reference Center) in *Increasing Efficiency in Mathematics and Science Education* (the SINUS project, see also the Companion Resource 3, *Setting up, Developing and Expanding a Centre for Science and/or Mathematics Education*, part II) on the whole territory of Bavaria has been extremely valuable – leading experts of the German Fibonacci team have visited Bulgaria, met with teachers and delivered talks at conferences and articles in proceedings and journals, selected parts of<sup>5</sup> have been translated in Bulgarian (published so far electronically<sup>6</sup>).



Field visits in project partner cities (Augsburg and Bayreuth) were very fruitful for the Bulgarian researchers and teachers. Problems and projects demonstrated by the hosting partners (e.g. patterns with polyominoes in a table with numbers (see also [section 4.1](#)) inspired the development of new dynamic scenarios<sup>7</sup>. The multiple discussions on the local education system and teachers' professional development, national educational standards and curricula, available didactical tools and materials were later shared at the bi-monthly Fibonacci seminar at the Institute of Mathematics and Informatics, BAS.



The visits of the Fibonacci project evaluators and consultants and their on-going support in following the professional development of the teachers have been also crucial for the next steps - identifying forty “*Fibonacci-teachers*” (Fibonacci project teachers) to act as cascade teachers in their respective schools.

The support for these teachers and the joint work with them has become the major task for the Fibonacci team in Bulgaria, and several seminars organised on both a national and international scale demonstrated that these teachers are capable and willing to help other teachers in applying the IBME approach<sup>3, 4</sup>.

Fig. 21 a+b: A *Golden feather* for creative applications of the ICT in the secondary school mathematics education

Putting the efforts and achievements of the Bulgarian Fibonacci teachers in an international setting contri-

butes to their self-confidence and pride of belonging to the European community of innovative educators. It is a special honor for the whole Bulgarian project team that Ms. Steliana Atanasova, a Fibonacci teacher from 119<sup>th</sup> Sofia School, received the Golden Feather Award of Bulgarian Teachers' Syndicate at the closing ceremony of the UNESCO International Workshop: *Re-designing Institutional Policies and Practices to Enhance the Quality of Teaching through Innovative Use of Digital Technologies*, Sofia 2011.

### 5.3.3 Enhancing the teachers' involvement in the dissemination of IBME

Another important initiative of the Bulgarian research team is to encourage the teachers involved in the project to report their good practices in implementing the IBME on the pages of specialised Bulgarian journals. The journals are meant for teachers and students of all ages thus disseminating the Fibonacci project ideas on a relatively large scale.

There are a number of dynamic scenarios prepared by teachers which are published (after revision) on the Bulgarian Fibonacci project site. The topics are among the most popular in the secondary school - graphs of functions, solving equations containing absolute values, extreme points of functions, systems of inequalities, systems of equations, systems of trigonometric inequalities, operations on fractions. The titles of the materials are quite conventional – very informative, sticking to the formulations in the official curriculum. In contrast, the titles of the teachers' articles published in the two specialised journals already convey the spirit of the IBME. Here are some examples

- from the *Mathematics and Informatics* journal (2010-2011):
  - Kuncheva, D.: *Let's not be shy to experiment.*
  - Petrova, D.: *Dynamics on the screen and among the students.*
  - Gushev, A.: *Dynamic mathematics for everybody.*
  - Atanassova, S.: *A fruitful error in a new dynamic environment, or The return.*
  - Kokinova, S.: *Do not be afraid to jump into the unknown (or why does the fortune helps the brave ones).*
- from the *Mathematics* journal (2012):
  - Petrova, D., A. Milanov, and P. Stefanov: *Two problems, dynamics, inquiries and something more.*

Let us note that the last two authors are 12 graders-students of Ms. Petrova.

Another interesting approach, applied by Angel Gushev (a Fibonacci teacher from Veliko Tarnovo) was to involve students in software design by assigning them mathematical projects. As reported by the teacher, his joint work on the projects with the students brought advantages to all of them and the most recent project *The method of inversion – properties and application* (Fig.22) gained the third prize at an international contest in Moscow.

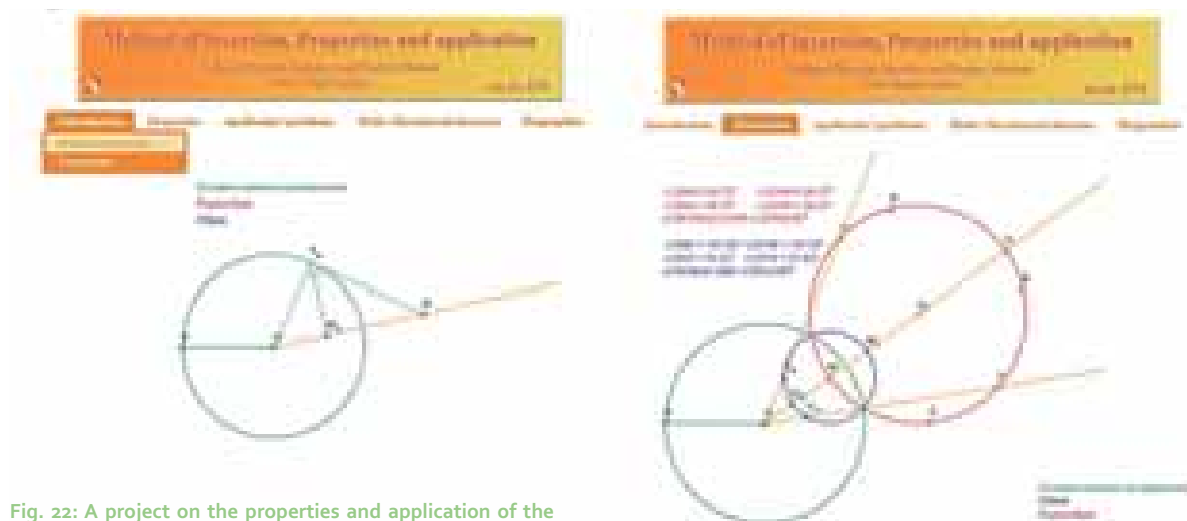

Fig. 22: A project on the properties and application of the inversion developed jointly by students and their teacher

Currently the papers presented by the Fibonacci teachers and researchers at the practical workshop *Inquiry Based Mathematics Education* held in Borovetz from 8 to 12 April, 2012 (in the frames of the 41st Annual Conference of the Union of the Bulgarian Mathematicians), are undergoing the final editorial phase so as to be published in full. The abstracts are published in Bulgarian in <sup>8</sup>. For you to get an idea about the variety of the topics and practices here are some titles of papers by teachers with illustrations of the products of their students:

- Atanasova, S.: *The loci – a good terrain for inquiry based mathematics learning in 12th grade.*

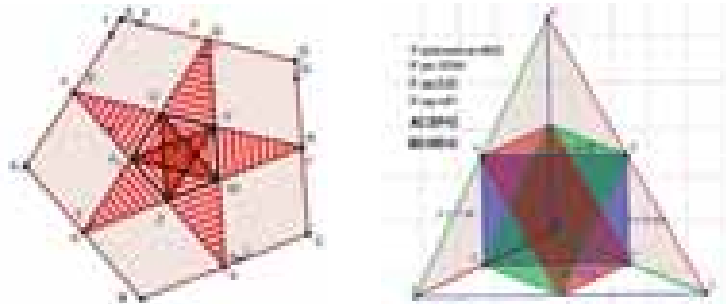

Fig. 23 a + b: Some interesting loci of points investigated by 12-graders

- Brauchle, M.: *How to create a dynamic scenario easily from technical perspective?*
- Cherkezova, K.: *My experience with the inquiry based learning in the IT classes (5 – 12 grades).*



Fig. 24 a + b: Elements of a website (<http://www.mathinit.comeze.com/>) designed by 5-graders

- Gancheva, Z.: *Dynamic figures of equal area for fun and explorations – a lesson for fifth-graders.*
- Gushev, A., Gushev, V.: *The Dynamic software – from zero to infinity.*
- Dankova, M.: *Regular grids and modules in the Fine Art classes.*
- Ilionova, S.: *Dynamic geometry in 5th grade – achievements and challenges.*
- Kokinova, S.: *A new jump in the unknown in the mathematics classes in 10th grade.*

- Kuncheva, D.: *Is there a room for the dynamic software in the Applied Art selective classes?*

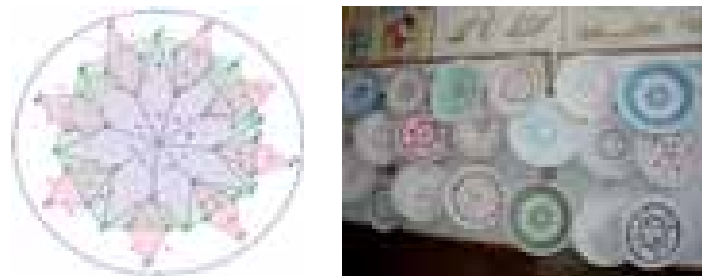

Fig. 25 a + b: Integrating dynamic mathematics in an applied art context



- Kuyumdzhieva, B.: *From curiosity to knowledge.*
- Bizova-Laleva, V.: *Applying the geometric congruencies in practice.*
- Marcheua, K., E. Velkov, and V. Stoilovski: *The exhibition as a stimulus for work.*

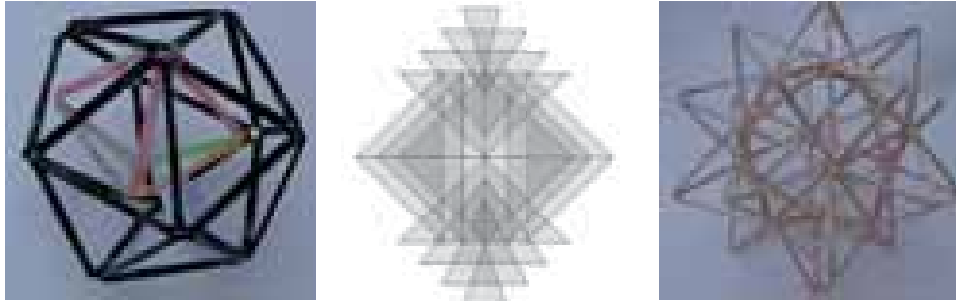

Fig. 26 a – c: Mathematics explorations stimulating the space creativity

- Stefanova, E.: *The geometric congruencies could be beautiful, not dry and boring.*



Fig. 27 a + b: Harnessing mathematics towards tessellations in the style of Escher

In some cases the contributions of the teachers found place in international editions <sup>9,10</sup>.

Although the scale of the Fibonacci project dissemination is relatively large in terms of the number of schools and teachers, it is extremely important to raise the awareness of the general public about the impact of the



Fig. 28 a: Playing with tessellation ideas by means of various tools

IBME on the students' motivation for learning. With this in mind the Bulgarian Fibonacci team has been involved in a number of social events dedicated to the attractive side of mathematics - interviews with local radio- and TV stations, creating films with the participation of teachers and students practicing the inquiry based approach, delivering presentations at international forums <sup>4</sup>. The European Researchers' Night (an event, having become already a tradition) turned out to be especially contagious with its "Dynamic mathematics". This was the title of a section at the premises of the Bulgarian Academy of Sciences where our Fibonacci team organised a quiz of puzzles (based on dynamic software) and an Escherization contest (creating tessellations in the style of Escher).



Fig. 28 b – d: Playing with tessellation ideas by means of various tools

The event was attended by children and adults, joining in teams to “take the gauntlet” thrown down by the organisers. Not only the random visitors, even colleagues expressed their sincere surprise that mathematics could be made so attractive and enjoyable for young people.

### 5.3.4 The lessons learned

As a result of their participation in the various project activities the Bulgarian Fibonacci teachers realised that it is their responsibility to organise successfully pupils’ own experience in the inquiry-based style. These teachers felt better prepared (not “trained”) for their new role - that of an advisor, consultant, stimulator, sometimes a partner, sometimes a therapist, but always a participant into creative process <sup>11</sup>.



Looking back at the challenges our trainee-teachers have overcome, we feel proud with their newly gained self-confidence, with their readiness to teach in a guided discovery style. Good examples of teachers’ creativity can be found in most of the schools today and our duty is to spread their achievements through journals and conferences for teachers, and based on such achievements to enrich the in-service and pre-service teacher training.

The main lesson for us as teacher educators could be summarised as follows: if we hope for a real positive change in education, we should bring today’s and tomorrow’s teachers in situations in which they would stop thinking about the future in terms of tests, exams or teaching pupils only. We should rather enable them experience what they are doing as *intellectually exciting and joyful on its own right* <sup>12</sup>.

Further on, we cannot teach *the guided discovery* style without engaging ourselves in assisting the art of discovery, without acting as research partners to the people we teach, without demonstrating how we try to solve the problems occurring during the research process.

## References

- 1 Kenderov, P.: Innovations in Mathematics Education: European Projects InnoMathEd and Fibonacci. Proceedings of the 39<sup>th</sup> Conference of the Union of the Bulgarian Mathematicians, Albena, Bulgaria, 2010, pp.63-72
- 2 Resources of the Fibonacci Project  
<http://www.math.bas.bg/omi/Fibonacci/archive.htm> (last visited 08/25/2012)
- 3 Kenderov, P. and E. Sendova: Enhancing the inquiry based mathematics education. UNESCO International Workshop: Re-designing Institutional Policies and Practices to Enhance the Quality of Teaching through Innovative Use of Digital Technologies, Sofia 2011, pp. 56-70
- 4 Chehlarova, T.: If I only had such a math teacher... UNESCO International Workshop : Re-designing Institutional Policies and Practices to Enhance the Quality of Teaching through Innovative Use of Digital Technologies, Sofia 2011, pp. 15-139
- 5 Baptist, P., C. Miller, and D. Raab (eds.): SINUS international, Towards new teaching in mathematics, Part I, II, III, Bayreuth 2010  
<http://www.math.bas.bg/omi/Fibonacci/archive.htm> (last visited 08/25/2012)
- 6 SINUS international (in Bulgarian)  
[http://www.math.bas.bg/omi/Fibonacci/docs/SINUS\\_Bg-ver4.pdf](http://www.math.bas.bg/omi/Fibonacci/docs/SINUS_Bg-ver4.pdf) (last visited 10/7/2012)
- 7 Chehlarova, T.: Polyominoes in a table with numbers  
<http://www.math.bas.bg/omi/docs/poliomino/index.htm> (last visited 08/25/2012)
- 8 Fibonacci workshop: Inquiry Based Mathematics Education (Abstracts), Borovetz 2012  
[http://www.math.bas.bg/omi/Fibonacci/docs/Borovets2012-all\\_abstracts-color.pdf](http://www.math.bas.bg/omi/Fibonacci/docs/Borovets2012-all_abstracts-color.pdf)  
(last visited 09/01/2012)
- 9 Atanasova, S.: An Olympic problem as a source of inquiry-based learning  
[http://www.dynamat.oriw.eu/materials/Sofia/Loci\\_Appendix\\_1.pdf](http://www.dynamat.oriw.eu/materials/Sofia/Loci_Appendix_1.pdf) (last visited 09/01/2012)
- 10 Chehlarova, T., E. Sendova, and Stefanova: Dynamic tessellations in support of the inquiry-based learning of mathematics and arts. In: Kynigos, C., J. Clayson, and N. Yiannoutsou (eds.): Theory, Practice and Impact - Proceedings of Constructionism, Athens 2012, pp. 570-574
- 11 Sendova, E.: Assisting the art of discovery at school age – a Bulgarian experience , 2011  
<http://www.worldtal.org/libros/Bulgaria.pdf> (last visited 10/06/2012)
- 12 Papert, S.: The children’s machine: Rethinking schools in the age of the computer. New York: Basic Books 1993

## Photo Credits

- Fig. 1: Source: Page Page 5B-2, Manual on Uniform Traffic Control Devices for Streets and Highways - 2003 Edition, License: public domain
- Fig. 2: Photo: Richard Bartz, Munich, License: CC-BY-SA-2.5
- Fig. 3: Photo: Wildfeuer, License: CC-BY-SA-3.0
- Fig. 4: Photo: Wilson Bentley, License: public domain
- Fig. 5: Norwegian Public Roads Administration (Statens vegvesen) website: <http://www.vegvesen.no/vegskilt/filnedlasting.stm>, License: public domain
- Fig. 6: Photo: Dave Fischer, License: CC-BY-SA-3.0
- Fig. 7: Chrysler Corporation, svg created by Scheinwerfermann, License: public domain
- Fig. 8: Photo: Keisotyo, License: CC-BY-SA-3.0
- Fig. 9: Photo: U.S. National Park Service, License: public domain
- Fig. 10: License: public domain
- Fig. 11: United Kingdom Government, License: public domain
- Fig. 12: Photo: Georges Jansoone, License: CC-BY-SA-3.0
- Fig. 13: Photo: Warren Rohner, License: CC-BY-SA-2.0
- Fig. 14: Photo: Uwe Kils, License: CC-BY-SA-3.0
- Fig. 15: Photo: Agricultural Research Service, the research agency of the United States Department of Agriculture, License: public domain
- Fig. 17: Photo: Julo, License: public domain
- Fig. 18: AlexanderAIUS, License: CC-BY-SA-3.0
- Fig. 19: Photo: NASA, License: public domain
- Fig. 20: Photo: code poet, License: CC BY-NC-SA 2.0
- Fig. 21a,b: Photo created by Evgenia Kovacheva, Sofia
- Fig. 25b: Photo created by Evgenia Sendova, Sofia
- Fig. 28 a - d: Photos created by Evgenia Sendova, Sofia

# 6 Inquiry Based Mathematics Education (IBME) and Gifted Students

---

*Petar Kenderov, Evgenia Sendova*

## 6.1 Introduction

As people involved in various aspects of gifted education, particularly in the context of mathematics and science, we have often argued that the *talent is a resource which, unlike the ores, could vanish if not discovered early enough ...*

Indeed, to appreciate the real beauty and meaning of mathematics/science and possibly choose it as their future profession the students should participate from an early age in activities enabling them

- I. to apply mathematical thinking and modeling in daily life;
- II. to use scientific methods as an integrated whole;
- III. to conduct their own explorations;
- IV. to formulate hypotheses and problems, and to attack open problems<sup>1</sup>.

An additional crucial competency of the future citizens of the knowledge&creativity based society is to build continuously knowledge throughout their life<sup>2</sup>.

All these activities and competencies are in the core of educational strategies based on the inquiry approach to learning. While this approach has been *natural* for the natural sciences it is relatively new in the context of the mathematics education. An important branch of the IBME is to encourage and develop the research potential of mathematically gifted high school students. It is interesting to note though, that the majority of existing empirical research on inquiry based learning has been only occasionally with specific attention to students with high ability<sup>3</sup>.

Still various forms exist for young mathematical talents to experience even at school age the specifics of the scientific research process: specialised research programs, school sections in the frames of professional conferences, symposia and fairs for young scientists. Many researchers in gifted education express their belief that educational programs outside of schools are absolutely necessary for gifted children because they meet their special learning needs by providing more opportunities for independent inquiry, in-depth study, and accelerated learning<sup>4</sup>. In addition, a summer program is a great chance to meet other students who are fascinated by learning. Courses in these programs combine the best of both worlds: accelerated content and bright age-peers. Summer programs vary in terms of content, duration, intensity, sponsorship, and overall purpose. Still some general benefits are found<sup>5</sup> to include the following:

- Perceptions of increased social support for learning and achievements due to homogeneous grouping and support from counselors, tutors, and mentors;
- Positive feeling resulting from a more appropriate match between the student's academic potential and the challenge of the research projects;
- Development of skills for intensive study and for doing scientific research;
- Reinforcement for risk taking as a result of extending oneself intellectually and socially;
- Growth in acceptance of others and (in the case of international component) knowledge of different cultures.

Below we consider two initiatives in this direction – one in Bulgaria, and one in an international context.

Raising students' mathematics and science curiosity, and developing their scientific competence have good roots established in the mathematics community in Bulgaria.

## 6.2 The High School Students' Institute – a Bulgarian model of mathematics and informatics research at school age

The *High School Students' Institute of Mathematics and Informatics* (HSSI) <sup>6</sup> was established in the year 2000. This was one of the undertakings of the Bulgarian mathematical community in response to the decision of UNESCO to designate 2000 *World Year of Mathematics*. The name "Institute" reflects the endeavor to have an organisation that functions like a research organisation, according to the principles of scientific life <sup>7</sup>.

The founders of HSSI were the *Institute of Mathematics and Informatics at the Bulgarian Academy of Sciences* (IMI-BAS), the *Union of Bulgarian Mathematicians*, *St. Cyril and St. Methodius International Foundation*, and *Evrika Foundation*.

The infrastructure of the HSSI has been adapted to the specifics of the local conditions – its activities are focused on projects in mathematics, informatics and information technologies <sup>8</sup>. Thanks to the well-developed network of competitions in mathematics, informatics and linguistics for secondary school students in Bulgaria <sup>9</sup> the young people can exhibit their abilities and gifts. For more than 20 years Bulgarian high school students successfully participate in the *International Olympiad in Mathematics* (IMO) <sup>10</sup>, in the *International Olympiad in Informatics* (IOI) and recently in *Theoretical, Mathematical and Applied Linguistics* (IOL). The last two events were in fact initiated by and hosted for a first time in Bulgaria, IOI – in 1989 <sup>11</sup>, and IOL – in 2003 <sup>12</sup>.

Competitions cultivate the ability to answer questions formulated by other people (the Jury of the competition). This ability is very important, no doubt about it. People living in knowledge&creativity based society however will operate in a challenging and demanding environment where the ability to formulate relevant questions and pose problems will be equally important. The best way to train and develop such ability is to perform research or research-like activities. This is what HSSI offers to students. While working on a specific problem the students do not only extend the volume of their knowledge. They learn also how one creates new knowledge. Thus, the main mission of HSSI is to *nurture the students' development as future scientists*.

The infrastructure and the activities of the Union of the Bulgarian Mathematicians, which has long-standing traditions in early identification and proper enhancement of talents, were an essential component of the local conditions. Since 1980, School Sections in the framework of the annual Spring Conferences of UBM have been organised for the high school students to present their papers. The interest in these sections shown by teachers as well as students has been great. This has contributed naturally to the mission of HSSI to *keep the traditions alive giving them a new spirit and a new content*.

Another important component was the environment provided by IMI-BAS stimulating the growth and the progress of HSSI. Many researchers at IMI-BAS have been devoting a significant part of their free time to keep the level of extra-curricular work with gifted students sufficiently high. Their work supports and enables HSSI to *assist the intellectual and professional growth of the high school students*.

The participants in HSSI are high school students between 8<sup>th</sup> and 12<sup>th</sup> grade, usually aged 15 to 18, predominantly from specialised Science and Mathematics Secondary Schools in the country. Every participant in HSSI works (possibly in a team) on a freely chosen topic in mathematics, informatics and/or information technologies under the guidance of a teacher or another specialist in the respective field. A written presentation of the project in the form of a paper is sent to HSSI. All papers are reviewed. Papers involving creativity elements are given special credit. The best projects are accepted for a presentation at special conference sessions of HSSI. The distribution of participants shows that big and small towns alike are involved in sending their representative in the HSSI <sup>13</sup>.

In the period of a school year HSSI organises three events - two conference sessions and a research summer school. The *High School Students Conference* is usually held in January and is attended by more than 200 students, teachers, researchers in mathematics and informatics, parents, journalists. The conference is held in two streams – mathematics and informatics/information technologies. The authors present their work in front of a Jury of specialists in the field and in the presence of the general audience. The Jury asks the students various questions so as to check the level of their understanding and creativity. The projects in informatics and information technologies are additionally run on computers to be judged by a specialist from technical point of view before being presented to the audience and the Jury. A poster session is held in parallel to these two streams.

Based on the merits of the paper and the style of presentation, the Jury judges the works and selects the best ones. Their authors receive Certificates for Excellence; all other participants are given Diplomas for participation in the event, which by itself is a high recognition.

The owners of Certificates for Excellence are invited

- I. to participate in the *School Section* of the Annual Conference of the Union of Bulgarian Mathematicians, and
- II. to be interviewed for the selection of two Bulgarian participants in the *Research Science Institute* (RSI) – an international summer program held at MIT (USA) <sup>14</sup> (to be considered in details in [section 6.3](#)).

The *School Section* could be also attended by students who present their research for a first time. The process of reviewing and selecting papers for the *School Section* is the same as above. The authors of the best projects from this section are invited to participate in the three-week *Research Summer School*, which takes place in July – August in two locations – at the sea coast and in the mountains. During the first two weeks, lectures and practical courses in mathematics and informatics are delivered by professional researchers from universities, academic institutions and software companies. The main goal of the training is to extend the students' knowledge in topics related to their interests and to offer new problems which become the core of short-term projects.

The third week is devoted to a *High School Students Workshop*, where the participants report on their short-term project's results and exchange ideas for further studies. The presentations are in front of specialists whose role is to advise the students in finding appropriate topics and problems to be studied, to recommend methods and tools towards achieving high quality results.

To help teachers improve their mentoring skills a *High School Teachers Workshop* is organised during the third week of the Research Summer School. Participants usually embrace the research advisors of the students' projects, presented at the events of HSSI during the school year, as well as (in 2011) selected *Fibonacci teachers*.

Several students from HSSI were specially invited to participate in various workshops (including within the Fibonacci project) to present their work demonstrating the potential of the dynamic software for attacking open problems and formulating their own ones <sup>15, 16</sup>. Here is what one of them recently accepted to study mathematics at Cambridge (UK) shares about the entrance exam and its possible connection with the Fibonacci project:

### Yanitsa Pehova

*The exam consists of eight math problems, three mechanics problems and two statistical problems and the grade is formed by these six of them you've solved best. The thing that caught my attention was the opportunity to choose these problems you are good at and show your skills there (in this case, to skip the problems you can't solve). I find this attitude to be exactly what Fibonacci should cultivate in teachers not only by introducing computer programs into the classroom but also by much simpler means of improvement... This exam avoids the obligation for you to study everything that is going to be on the exam instead of just focusing on what's interesting to you and what you are good at, somehow compensating for your poorer knowledge in other areas. So to say, if you are born a fish, there is no point in trying to climb trees when you could practice your swimming skills; they both count as Physical Education. Moreover, such an exam helps students make discoveries by taking small steps: not only is the form of the exam different but the problems, too. They are usually built around a simple statement and consist of little steps in the form of sub-problems that build up to a general result. Encouraging research in school is what our High School Science Institute (HSSI) has been doing for years but only with already exceptional students. I think this way of school examining is an opportunity for even ordinary students to engage in math research and develop skills in a specific area they find interesting... something like a High School Science Institute Way of Teaching (HSSIWT)!*

Another important activity of the HSSI is its monthly seminar at the Institute of Mathematics and Informatics. The aim of the seminar is to bring together high school students, teachers and scientists to present and discuss problems of common interest.

It is since year 2000 that the HSSI is in charge of selecting the Bulgarian representatives for RSI. The Jury includes researchers from the Institute of Mathematics and Informatics, other research institutions, representatives from *St. Cyril and St. Methodius International Foundation*, *America for Bulgaria Foundation*, and very importantly – RSI alumni. The members of the Jury would already have an idea about the research potential of the candidates so the students would additionally demonstrate their fluency in English, their general and professional culture, their talents in singing, dancing, poetry, fine arts (sometimes - even in magic performances), as well as their social skills.

In an attempt to convey the atmosphere of the interview let us share some interesting moments of a recent one<sup>17</sup>. One of the challenges coming from a member of the Jury was: *Quote a fundamental theorem proved in the last 50 years which is not the Fermat's Great Theorem*. The student being interviewed formulated (with no hesitation) a result presented by two of his HSSM peers, also applying for RSI. Another memorable answer was given to the question: *What is the next line in the monolog "To be or not to be; that is the question"*. The student immediately responded: *The question is not "To be or not to be", the question is "What to be" ...*

The Jury smiled at the ambitions of another participant who expressed his regrets that Grigori Perelman has already turned the Poincaré conjecture into a theorem and thus has solved a problem which was both among *Hilbert problems* and the *Millennium problems* – something that deprived our hero of achieving the same...

Often it is from the questions of the RSI alumni that the candidates realise better what the participation in RSI is – not only a great honour but a challenge and a responsibility to pass what they have learned to their peers and to the younger HSSI generation. Finally, the two representatives are chosen based on their overall performance – the work on a project, the presentation skills, the achievements in mathematics and informatics events, and the interview.

The most important result of HSSI is the qualitative difference in the knowledge acquired by students taught in the traditional manner and by the HSSI students. In order to work successfully on a given project the latter students learn a lot of additional material, often going far beyond the obligatory syllabus. They understand much deeper the topics they learn and are able to apply their knowledge to finding answers to questions and conjectures they themselves formulate. This is what happens in real research. The opportunity to present results to peers makes the similarity with science even stronger. In fact, the students of HSSI get a rather real picture



of what science is and acquire practical habits in doing research. What happens in HSSI is a genuine example of inquiry based learning where the students “are discovering” knowledge themselves by searching the existing classical literature and Internet resources, by combining in an original way known facts and, sometimes, are obtaining original results about the studied topic. The teachers (supervisors in our case) do not provide the knowledge in terms of direct instruction. They help the students develop the necessary research skills (analytical thinking, formulation of conjectures, experimental verification of the conjectures, etc.) and guide the overall process of work.

On the occasion of the 10<sup>th</sup> anniversary of HSSI its activities and achievements were presented at the 39<sup>th</sup> conference of the Union of the Bulgarian Mathematicians<sup>18</sup>. Several people closely involved in the HSSI activities also shared their thoughts about this institution, unique in a Bulgarian setting:

**Stefan Dodunekov** (the late President of the Union of the Bulgarian Mathematicians and President of the Bulgarian Academy of Sciences):

*Even if HSSI would be the only thing left after us, as educators, I would be endlessly happy. I feel very proud for having the chance to be able to contribute to the founding of this Institute. Nurturing and stimulating young talents as well as the development of mentoring skills of the mathematics and informatics teachers are extremely important.*

**Boriana Kadmonova** (President of Evrika Foundation):

*To me the founding of HSSI was a very significant event, organised by people who have dedicated their professional life to the young people so that they could surpass their teachers and achieve their dreams for a life realisation. Unifying the knowledge and the experience of us, the elder people, with the motivation and the scientific endeavour of the youngsters, creates the magic – the magic, which attracts every year a new crowd of students from all over the country, ready for new ideas and projects. The feeling to be part of something magic, something useful, something being a symbol of youth, creativity, future and a lot more makes me happy ...*

**Oleg Mushkarov** (Director of the HSSI):

*The activities of the Institute were acknowledged in the contexts of the European projects meeting in mathematics and Math2Earth as the best practices with gifted high school students in mathematics and informatics. In the last three years the best five informatics students from HSSI are admitted to participation in the International Conference CompSysTech conducted every year in Bulgaria and comprising scientists from all over Europe. The two students selected each year by HSSI to participate in RSI performed really well. The projects of Kaloyan Slavov (2001), Vesselin Dimitrov (2003), Antony Rangachev (2004), Galin Statev (2008), and George Kerchev (2009) were ranked among the representative five in RSI in the respective years \*. Several articles with results obtained by HSSI students were published in regular scientific journals. During 2009 an international commission of about 40 scientists from more than 15 countries evaluated the activities of every institute of the Bulgarian Academy of Sciences. The achievements of the IMI related to the identification and nurturing of young talents were evaluated very highly. The evaluating commission was impressed by the fact that eminent Bulgarian scientists in various fields of mathematics and informatics work directly with gifted high school students and are involved in their development at a level comparable with the most developed countries.*

\* This list should be updated with the names of Todor Markov (2011) and Kalina Petrova (2012) who received the same recognition for their written presentations.



**Neli Dimitrova** (Coordinator of HSSI till 2006):

*I started working as a coordinator of HSSI from its very founding. The first years were the most difficult ones, but very exciting at the same time. These were the years during which the goals, the mission, the structure and the activities of the Institute were taking shape. There was a lot of work – organisational, administrative, financial, coordination of the scientific support of the HSSI conferences and summer schools. How could one embrace so many and so versatile activities? There is a single answer – with much love, devotion, dedication – the way a mother (and only she) is able to dedicate herself to her children.*

**Borka Parakozova** (Coordinator of HSSI since 2006):

*The ongoing contact with the young people is very enriching experience. I am always moved from the expressions on the faces of the candidates for RSI immediately after they have been interviewed. And I make a comparison with how they look like after the results have been announced. Some are happy, other – disappointed, there are even tears. I would like to see a greater number of happy faces but the number of the lucky winners is fixed... I hope that the HSSI alumni after their graduation in prestigious universities around the world would not forget us and would pass the torch to the next generations of young talents.*

It is worth mentioning that HSSI did not start from scratch – it inherited the good experience and traditions of an earlier movement of the technically creative youth in Bulgaria, and implemented partly the model of the *Research Science Institute* (RSI) which we present next.

## 6.3 The RSI international summer program and the challenge to describe it by one word

Let us start with an attempt to describe RSI with one sentence: “the place where to be extraordinary is the most ordinary thing”... This applies to the students, to the mentors, to the morning- and evening lecturers, and to all the rest officially and unofficially involved. A few words about the RSI’s founding and principles <sup>13</sup>:

The *Research Science Institute* was created within the *Center of Excellence in Education* (CEE) co-founded by the late Admiral Hyman George Rickover, father of the Nuclear Navy, and Joann DiGennaro, who serves as the current president of CEE. Towards the end of his life, Admiral Rickover began to bring together high school students from across the United States and other countries who showed a high interest and ability in science and mathematics. His idea was to create a community of exceptional scholars, including these students, noted high school teachers, university professors, and working research scientists. The six-six week RSI program was launched in 1984. Today it embraces about 2,000 alumni.

RSI is attended by 50 American and approximately 30 international students. While the list of the foreign countries sending participants in RSI change from year to year it includes Australia, Bulgaria, China, France, Germany, Greece, Hungary, Israel, India, Korea, Lebanon, Poland, Qatar, Saudi Arabia, Singapore, Spain, Sweden, Switzerland, UAE, and the United Kingdom. Once selected, the students come to MIT and work on a research project under the guidance of faculty, post-docs, and graduate students at MIT, Harvard, Boston

University, and other research and industry institutions from Boston-area (e.g. Massachusetts General Hospital, Harvard Medical School, Hewlett-Packard Company, Akamai). All the students chosen for the program will have already acquired a deep interest in a scientific field of inquiry, and have found opportunities to acquire some form of field experience. The Institute begins with four days of formal classes. Professors of physics, biology, chemistry, engineering and mathematics (usually RSI alumni) give lectures on important aspects of their field and their own research. The students also attend lectures in humanities integrating literature and cinema arts (Frankenstein and Odyssey being the topics of the recent RSI years).

The internships that follow the formal classes comprise the main component of the Institute. Students work in their mentors' research laboratories for five weeks. At the conclusion of this internship, they present a paper summarising their results and give an oral presentation of their work in front of a large audience at the RSI Symposium.

The RSI staff chooses ten oral presentations to present again at an "Encore Presentation session" to guest judges (professionals from various institutions in and around Cambridge). The guest judges then choose five presentations as the "representative talks" of the specific year.

A typical RSI paper could be best characterised as a *progress report* for a continuing research effort throughout the program. The transition from progress report to a final research paper is typically one of reduction of the existing text through editing offered by the tutors with the perspective of the final results in mind. In addition, the last week teaching assistants and *nobodies* (RSI alumni with no formal duties) supply editing advice of great quality in the week before the papers are due. Especially important in the process of preparation are the *milestones* – intermediate steps of the process. Typical milestones for the written presentation are: writing about a mini-project using the same sample as the one for the final paper; gradually filling the proposed sample starting with the background of the project, the literature studied and the methods used; considering partial cases and possible generalisations; classifying the cases of failure (in the case of mathematics projects), etc. Possible milestones for the oral presentation are: speaking for 3 min on a freely chosen topic, presenting the introductory part of the project for 5 min, presenting in open space (without visual aids), etc.

Here are some examples of mini-project titles under the topic "Do an experiment involving an art object found on the MIT campus. Create a hypothesis, perform an experiment, analyse the data" (RSI 2012):

- Distribution of Distances between Adjacent Pseudo-Reflecting Rectangles at the MIT Chapel
- Ratio of Tourists Stepping Inside the Alchemist Sculpture
- Visibility of the MIT Logo Formed by Parts of Wiesner Building
- On the Eastman Plaque's Rubbed-out Lucky Areas
- The Golden Ratio in Works of Art Around MIT Campus
- Measuring the Infinite Corridor

The variety of ideas and wish to be original could be seen even from this small sample. What is "the same" though is the structure:

- I. background, including context and motivation;
- II. methods, including controls and experimental apparatus; main results; discussion of the results; conclusions, acknowledgments, references.

All the milestones are accompanied by a feedback from the tutors, who work closely with the students. The role of an RSI tutor (performed by the second author since 1997) is to help the students in presenting their "journey of explorations" in a *suitable* written and oral form. The tutors read and critique the draft papers, provide editorial remarks, suggest avenues of research and areas of additional background reading, give ideas for tuning the oral presentations to the specific RSI audience, etc. *How to cope with the anxieties of these gifted students, how to help them to adjust to the requirements of the research, how to support them when feeling "stuck" without depriving them from the joy of the ownership of their work, how to help them to enjoy the team work, how to distribute their time between "pure research" and documenting it* – all these questions are components of a collective know-how tutors are expected to gain and spread further to the novice tutors. In general, the tutors are kind of *psychological oil* in a very complex mechanism.

To get an idea of the variety of topics of projects performed at RSI one might look at the compendiums of three consecutive years<sup>19</sup> containing the abstracts of all the written reports with five selected as representative for the respective year (published in full).

The titles of the projects of the Bulgarian RSI participants since 2001 are as follows:

- **On Hurwitz equation and the related unicity conjecture**
- A Generalisation of Poncelet's theorem with application in cryptography
- Graph embeddings
- Implementation of motion without movement on real 3D objects
- **Zero-sum problems in finite groups**
- A novel command protocol used in a virtual world games framework
- **On the solvability of  $p$ -adic diagonal equations**
- Creating custom board games for fun and profit
- The number of isomorphism classes of groups of order  $n$  and some related questions
- Application of decision trees and associative rules to personal product recommendation
- Representations of integers as sums of square and triangular numbers
- Dynamical processes in real-world networks
- On a linear Diophantine problem of Frobenius
- Searching for repeating microlensing events
- **On Fermat-Euler Dynamics**
- Rational Cherednik algebras of rank 1 and 2
- **On the filtration of the free algebra by ideals generated by its lower central series**
- A multi-objective approach to satellite launch scheduling
- On the Hausdorff dimension of cycles generated by degree  $d$  maps
- The competitiveness of binned free lists for heap-storage allocation
- **Extremal degrees of minimal Ramsey graphs**
- Rational fixed points of polynomial involutions
- Visualizing the energy landscape of a regulatory network in the presence of noise
- **Graph theory applications in neuron segmentation**

The titles of the papers selected among the five representative ones are in bold.

The atmosphere of nurturing young talents in science, an atmosphere of removing the impediments of their intellectual growth and supporting their natural desire to explore and create is inspirational. The students learn what research is by doing research under the guidance of experienced mentors.

The RSI mentors are typically renowned specialists in a specific scientific field often possessing deep knowledge in various other fields and multiple artistic talents; in short they are good models for the students to follow. One of them, a mentor in projects in theoretical physical chemistry, describes (as quoted in<sup>13</sup>) his RSI students as a *secret weapon* in furthering theoretical physical chemistry research, particularly in cutting-edge and high-risk area: *My own strategy is to be conservative when I provide my ideas in a great proposal, but I give the RSI students exploratory projects that I or my graduate and post-doctoral students would never try!* Another mentor, a specialist in quantum mechanics, shares his impressions about his RSI student:

*His great enthusiasm was highly communicative: I would explain something to him, and his face would light up almost immediately – he was often ahead of my explanations. He has a great capacity to absorb material; I would often wonder whether he was following the discussion, and realise only afterwards that he had already been preparing questions, always racing forward. He was impressively quick to grasp complex ideas, and was able to reformulate them in his own words in a very clear way – a sure sign of deep understanding. This was especially impressive given the project involved familiarising oneself with some deep concepts in quantum mechanics that he had never before been exposed to. I am sure that he will have an astonishing career, whatever field he eventually decides to get into.*

The mentoring in mathematics has its specifics though – the mentors are often graduate students working as a team under the guidance of a coordinating mentor – a model established by Prof. Hartley Rogers, a legendary figure at MIT. After students have exposed their research interests and mathematical background in their essays the mentor of mentors discusses the research preferences of the RSI students with the mentors-to-be and matches them according to their respective research interests and background. Here is what Prof. Rogers says about his involvement in RSI <sup>13</sup>:

*This system has been surprisingly successful. Solving new mathematical problems is a chancy and unpredictable undertaking. In particular, the timing of success cannot be legislated in advance ... But on the whole, the quality of the RSI students was so high, and the enthusiasm of the mentors was so great, that extraordinary results were achieved.*

From the view point of the mathematics mentors the process is difficult but rewarding as seen from the following fragments from their evaluation forms (presented to the CEE after the program):

*The approach to designing a project depends greatly on the student's previous experience... This makes the choice of problem particularly crucial. The desire of students to work on unsolved problems makes this choice even harder. I would sacrifice the latter goal in favor of giving the students something they can get to grips with without too much hand-holding.*

*My work at RSI was both pleasurable and difficult. The nice part is meeting talented and enthusiastic students who are eager to learn mathematics through their own investigations rather than one-way instruction. The difficult part is that a great deal of thought and patience is required since introducing high school students to mathematical research means teaching many important skills at once.*

The transforming process of the RSI summer program happens at a critical time in the lives of the students. It is a time when they begin to make choices for themselves that will define the course of the rest of their lives. It is an emotional time when friendships are made that can last a lifetime.

Immediately following the summer program, *Rickoids* (as the students are called after Admiral Rickover) stay in contact with each other and with the staff, virtually and many continue to work with their mentors on research projects. The contributions, devotion, and intellectual strength that the whole RSI community brings to the program year after year are impressive.

It would be interesting to hear some thoughts of the students on doing research in the context of the summer programs considered:

**Sam Backwell** (Australia, RSI 2011):

*During our evening lecture series, Noble Laureates and industry leaders from companies like Google and IBM talked openly about the evolution of science that they, personally, have had a hand in. Discussions ranged from viruses to the global financial crisis and from astrophysics to the next generation of computers. I, personally, was privileged to have dined with Dudley Herschbach who received the 1986 Nobel Prize in Chemistry and started his research before much of the content of my chemistry book was known... I developed a computer program which sorts different types of atoms and then compares the displacement of individual atoms on their neighbours. While the results are very cool although quite complicated the sense of ownership I felt about the simple blue image you may have seen I got on the screen and the over 1000 lines of code I wrote are far more valuable to me. There's a special thrill coming when you do, or discover something no one has done before and this is one of the biggest gifts of RSI.*

**Kristina Hu** (US, RSI 2011):

*Many people (including myself) expected prior to RSI that it would be a fairly academic experience where the students would be extremely focused on their own projects and ideas. What amazed me the most was the amount of collaboration between the Rickoids; not only were people genuinely interested in learning from their fellow peers, but everyone seemed to harbor an extreme desire for their efforts in science to impact society in a positive way. Before RSI, I had never imagined the extent of the applications of research. Now, I know that together with my peers, we have the potential to do great things for the world and its people – and that is the most empowering feeling.*

**Allan Ko** (US, RSI 2012):

*Though both RSI and my mentorship at home gave me amazing opportunities to conduct independent research, RSI made it a life-changing experience by placing me in a community of students and staff as passionate about science as myself. Whenever I was stuck or had questions, there was always somebody nearby that I could talk to for help, ideas, or advice. Working late into the nights writing up code or papers is never easy, but simply having a group of friends all working in the same room sharing the same struggle and helping each other made the burden much lighter. With the wonderful staff's expertise and the students' shared camaraderie and passion for science, RSI gave me not only a high-level research opportunity, but also an unparalleled environment and community that never failed to guide, support, teach, and inspire me in my work – something that I didn't have as much of when I was working at home by myself. ...As much as research and science is, RSI is so much more – it is love and family, a community of students that share a common passion and drive. RSI is being amazed by everyone's intelligence and good nature, the fact that everyone is brilliant and yet no one would be able to tell from an everyday conversation, the way that encountering their genius makes me feel not inferior, but inspired.*

**Katerina Velcheva** (HSSI and RSI 2010):

*Before participating in RSI the interesting project for me were those dealing with ordinary ICT applications. Now I consider a project interesting if it is challenging enough, if it is related to science, theory, something new, undiscovered, something nobody has done before... My wish to do science became stronger than ever. RSI was a place where I met people from all over the world sharing my interests and for that I'll be eternally grateful.*

**Rafael Rafailov** (HSSI and RSI 2010):

*RSI was a great experience for me, as I had the chance to work on a problem proposed by a mathematician of the rank of Prof. McMullen (a Fields medalist) who gave it to me to work on in the future.*

*The RSI program taught me that things don't always go the way you expect them to go, but that one should always try to get the maximum out of every situation and not regret about anything, a lesson I think would be very useful in the future.*



**Valeria Staneva (HSSI and RSI 2012):**

*RSI is both characterized by endless research opportunities and a strong, supporting community. We had the chance to work with some of the best scientists in the world, even though we are only high school students. I worked with Dr. Regan from Beth Israel Deaconess Medical Center in the field of computational systems biology on the design of an algorithm that can model and visualise the energy landscape of a cell's regulatory network. Having such a tool could aid the process of drug development and have an important impact on biomedicine as a whole... At RSI, we learned not only about science but also about decision making. During these marvelous six weeks, I have been enveloped in an environment of care, curiosity and dedication, a phenomenon we call "RSI love"... At RSI, I learned how happy it makes me to do research. I now realise that I definitely want to pursue a career in computational biology.*

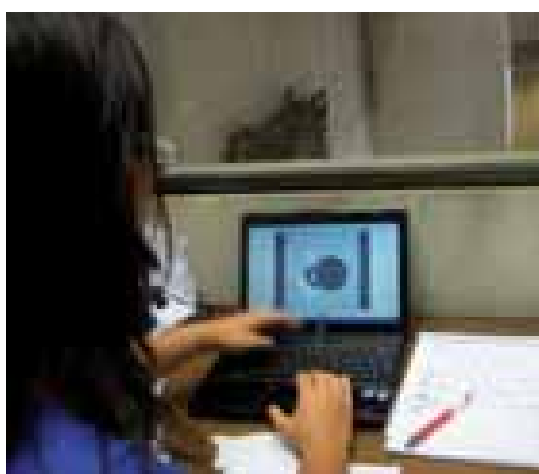

Fig. 1 From the first milestone ...



Fig. 2 ... to the final presentation

**Kalina Petrova (HSSI and RSI 2012):**

*HSSI has played a great role in my learning how to write scientific text, how to present my achievements and how to speak in public. But there is more to it than that. The conferences and the summer schools have given me the kind of scientific interest that drives me to explore every unfamiliar concept and to delve into every unconventional idea I get. Moreover, HSSI has had a great impact on forming the Bulgarian student scientific society. This is a group of people who share my interests and with whom I can have conversations on subjects that really matter to me. Unlike my RSI friends, I see these people every few months and time spent with them has grown to be an important part of my life. I particularly like the notion that in whichever Bulgarian town or city I go, I have a friend there to see.*

*My project at RSI was in computational neuroscience, which meant learning a great deal about how the brain functions. That was an unusual experience for me because I have always been prone to delving into mathematics, computer science and physics and not paying attention to other scientific fields... I did not expect meeting somebody who would be better than me at absolutely everything – and indeed I met more than one person fitting that description. My competitive nature had huge difficulties handling that. However, by the end of RSI I had learned new things about myself too – I had never even imagined that I was physically capable of spending ten days with severe sleep deprivation and being productive almost constantly at that. RSI was about getting the best out of myself – it was about running five miles despite the horrible pain in my ankles in order to not let my companions down; but it was also about taking advantage of the stimulating environment while expressing my own uniqueness in the best possible way. In that train of thought, I think I grew a little bit wiser – now my inherent maximalism is successfully coexisting with humbleness towards other people's talents and skills no matter how great they are.*

In the summer book produced by all the students at the end of the program there is a challenge to describe RSI with one word only. Among the many interesting ideas one finds the following: *inspiring, memorable, short, awesome, brofinity, sleepless, exhausting, magical, odyssey, intense, indescribable, onewordisn'tenough, surreal, liberating*. And the last one showing that the one-word description of RSI is really a challenge: *Amazing. Unbelievable. Inspiring. Life-changing. Eye-opening. All of these together cannot capture the essence of RSI.*

Let us mention at the end that one of the crucial factors for transferring the RSI experience within the HSSI model was the long-term collaboration between the *Center for Excellence in Education*, the *Institute of Mathematics and Informatics at the Bulgarian Academy of Sciences* and the *St. Cyril and St. Methodius International Foundation*. In the recent couple of years, the financial support of *America Foundation for Bulgaria* has also been decisive for sending Bulgarian participants at RSI.

## Conclusions

In conclusion we share our belief that disseminating inquiry-based science and mathematics learning as a major transversal competence will contribute to the building of a knowledge&creativity based society. When provided with the right research environment the students feel stimulated and supported to achieve their best while acting like scientists and problem solvers, and to apply these competencies during a lifetime. This will help them not only to keep in pace with the development of a specific professional field, but to do *cutting-edge science*, and to demonstrate crucial competencies in a wider spectrum of life.



## References

- 1 Mushkarov, O., A. Rangachev, and E. Sendova: Entering the World of Mathematics Research at School Age. *Mathematics and Education in Mathematics*, 38, 2009, pp. 92–94
- 2 Kenderov, P. and E. Sendova: Towards Enhancing the Inquiry Based Education. In: *Proceedings of the UNESCO International Workshop Re-Designing Institutional Policies and Practices to Enhance the Quality of Education through Innovative Use of Digital Technologies (QED)*, Sofia 2012
- 3 Robinson, A, B. Shore, and D. Enersen: *Inquiry-Based Learning and Teaching*. Chapter 12 of *Best Practices in Gifted Education*, Prufrock Press, Inc. Waco Texas, 2007
- 4 Olszewski-Kubilius, P.: Special Summer and Saturday Programs for Gifted Children. In: N. Colangelo and G. Davis (eds.): *Handbook of Gifted education*, 3rd ed. 2003
- 5 Colangelo, N., S. Assouline, and M. Gross: *A Nation Deceived: How Schools Hold Back America's Brightest Students*. vol. The University of Iowa, Iowa City 2004
- 6 High School Students Institute of Mathematics and Informatics (HSSI)  
<http://www.math.bas.bg/hssi/indexEng.htm> (last visited 08/24/2012)
- 7 Kenderov, P.: Higher Ability Students and Inquiry Based Learning in Bulgaria – the Role of European Projects InnoMathEd and Fibonacci. *Proceedings of the 6-th Conference of the World Federation of National Mathematics Competitions (WFNMC)*, Riga 2010
- 8 Dimitrova, N., O. Muskarov, and E. Sendova: Enhancing the research potential of mathematically gifted high school students. *Acta mathematica* 13, zväzok 2, Edícia: PRÍRODOVEDEC, publikácia č. 420, Nitra 2010
- 9 Mathematics and Informatics Competitions Scene in Bulgaria  
<http://www.math.bas.bg/bcmi/intro.html> (last visited 09/26/2012)
- 10 Georgiev, V., A. Mogensen, and O. Mushkarov: Math competitions – achieving your best. Chapter 3 in *Meeting in Mathematics*, Sofia, 2008, pp. 39-48
- 11 Kenderov, P.: Bulgaria – Birthplace of International Competitions in Informatics for School Students. *IT STAR NL* Vol. 5, no. 3, 2007
- 12 The 1<sup>st</sup> International Linguistics Olympiad  
<http://www.ioling.org/2003/> (last visited 09/26/2012)
- 13 Muskarov, O., N. Dimitrova, and E. Sendova: Math Research at School Age – 6<sup>th</sup> chapter. In: Georgiev, V., et al: *Meeting in Mathematics*, Sofia, 2008, pp. 113-135
- 14 Research Science Institute, <http://www.cee.org/programs/rsi> (last visited September 26, 2012)
- 15 Pehova, Y.: The story of a project (or how can GeoGebra help in a difficult situation).  
[http://www.dynamat.oriw.eu/materials/Sofia/Loci\\_Appendix\\_2.pdf](http://www.dynamat.oriw.eu/materials/Sofia/Loci_Appendix_2.pdf) (last visited 08/23/2012)
- 16 Bukovski, K. and A. Belev: When you simply decide to dream...  
[http://www.dynamat.oriw.eu/materials/Sofia/Loci\\_Appendix\\_3.pdf](http://www.dynamat.oriw.eu/materials/Sofia/Loci_Appendix_3.pdf) (last visited 08/23/2012)

- 17 Parakozova, B. and E. Sendova: When to be exceptional is not an exception – an interview with HSSM students applying for RSI 2010. Mathematics and informatics journal, vol. 1, Ministry of Education, Youth and Science, Sofia 2010, pp. 22-28
- 18 Kenderov, P. and O. Mushkarov: Ten years High School Institute of mathematics and informatics. Mathematics and Education in Mathematics, 39, 2010, pp. 7-20
- 19 RSI Compendiums 2003-2005,  
<http://stuff.mit.edu/afs/athena/course/other/rsi/compendium/final/> (last visited 09/26/2012)

## Photo Credits

Fig. 1 – 2:        Photos: Evgenia Sendova, Sofia, Bulgaria

This document is the result of the common work between the following Fibonacci partners:

University of Augsburg, Germany  
Contact person: Volker Ulm



University of Bayreuth, Germany  
Contact person: Peter Baptist



University of Zurich, Switzerland  
Contact person: Peter Gallin



Universität Zürich  
Institut für Gymnasial- und Berufspädagogik

University of South Bohemia, Czech Republic  
Contact person: Pavel Pech



Academy of Sciences, Bulgaria  
Contact person: Petar Kenderov



Thuringian Institute for Teacher Training  
and Quality Management, Germany  
Contact person: Jörg Triebel



## Credits

Template design : Brice Goineau

Graphic design : [www.lezard-graphique.net](http://www.lezard-graphique.net)

Layout : GAUBE media agentur, Bayreuth, Germany, [www.gaube-media.de](http://www.gaube-media.de)

Proof Reading: David Brueske, Cornillie Consulting, [www.cornillie.com](http://www.cornillie.com)

*The document is available, free of charge, at  
[www.fibonacci-project.eu](http://www.fibonacci-project.eu) within the Resources section*



*This document is protected under a creative commons license.*

*The content of this document reflects only the author's view ; the European Commission is not liable for any use that may be made of the information contained therein.*



## Summary

How can we promote mathematical understanding? How can our maths classrooms become centres of vivid mathematical thinking?

We have to create situations that challenge the curiosity of the students. Teachers should pose problems proportionately to their students' knowledge and help them to solve these problems with stimulating questions. More than by reading and listening, mathematics is learned by really doing maths.

The authors of this book deliver insight into the diversity of practising inquiry-based mathematics at school, at different school levels, in different countries, and with different methods. They also give vivid examples of international cooperation as an important success factor for developing common strategies to foster inquiry based teaching and learning.



## CONTACT DETAILS

### **European coordination Fondation *La main à la pâte***

1 rue Maurice Arnoux  
92120 Montrouge - FRANCE  
+33 (0) 1 58 07 65 97  
[Fibonacci@fondation-lamap.org](mailto:Fibonacci@fondation-lamap.org)

### **Scientific coordination for mathematics**

#### ***Peter Baptist***

University of Bayreuth  
Chair of Mathematics and  
Mathematics Education  
95440 Bayreuth - GERMANY  
+49 (0) 9 21 55 32 66  
[peter.baptist@uni-bayreuth.de](mailto:peter.baptist@uni-bayreuth.de)

[WWW.FIBONACCI-PROJECT.EU](http://WWW.FIBONACCI-PROJECT.EU)

ISBN 978-3-00-040752-9